

PENGUIN[®]
SOLUTIONS 

Stratus
ztC Endurance[™]

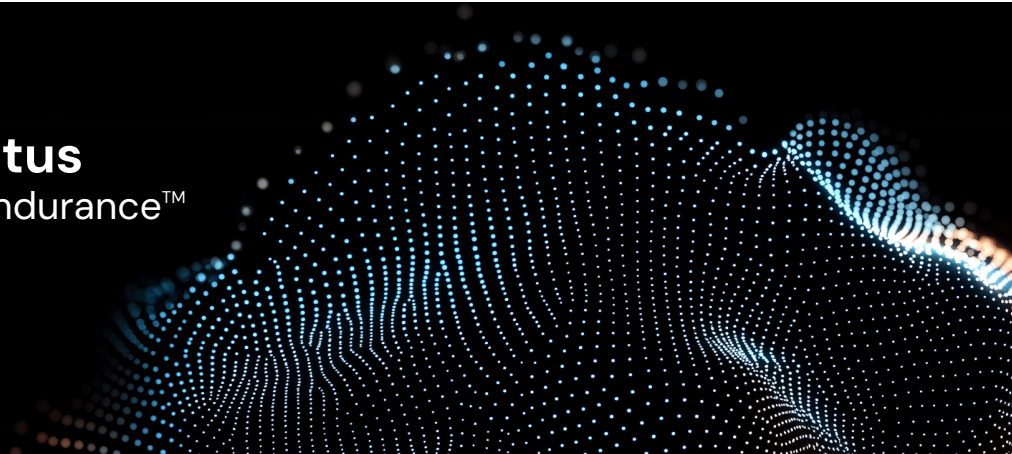

ztC Endurance 3xx0, 5xx0, and 7xx0 Systems: User's Guide (VMware) (R003C)

Notice

The information contained in this document is subject to change without notice.

UNLESS EXPRESSLY SET FORTH IN A WRITTEN AGREEMENT SIGNED BY AN AUTHORIZED REPRESENTATIVE OF PENGUIN SOLUTIONS, PENGUIN SOLUTIONS MAKES NO WARRANTY OR REPRESENTATION OF ANY KIND WITH RESPECT TO THE INFORMATION CONTAINED HEREIN, INCLUDING WARRANTY OF MERCHANTABILITY AND FITNESS FOR A PURPOSE.

Penguin Solutions assumes no responsibility or obligation of any kind for any errors contained herein or in connection with the furnishing, performance, or use of this document. Software described in Penguin Solutions' documents (a) is the property of Penguin Solutions (PENG) Ireland Limited or the third party, (b) is furnished only under license, and (c) may be copied or used only as expressly permitted under the terms of the license.

Penguin Solutions' documentation describes all supported features of the user interfaces and the application programming interfaces (API) developed by Penguin Solutions. Any undocumented features of these interfaces are intended solely for use by Penguin Solutions personnel and are subject to change without warning.

This document is protected by copyright. All rights are reserved. Penguin Solutions grants you limited permission to download and print a reasonable number of copies of this document (or any portions thereof), without charge, for your internal use only, provided you retain all copyright notices and other restrictive legends and/or notices appearing in the copied document.

Copyrights

Stratus, the Stratus logo, Stratus ztC, the Stratus Technologies logo, the Stratus 24x7 logo, Stratus ztC Endurance, Smart Exchange, and Automated Uptime Layer with Smart Exchange are trademarks of Penguin Solutions, Inc. or its affiliates.

Intel and the Intel Inside logo are registered trademarks and Xeon is a trademark of Intel Corporation or its subsidiaries in the United States and/or other countries/regions.

Microsoft, Windows, Windows Server, and Hyper-V are either registered trademarks or trademarks of Microsoft Corporation in the United States and/or other countries/regions.

VMware, vSphere, and ESXi are registered trademarks or trademarks of VMware, Inc. in the United States and/or other jurisdictions.

Linux is a registered trademark of Linus Torvalds in the United States and other countries.

Oracle is a trademark of Oracle International Corporation.

Google and the Google logo are registered trademarks of Google Inc., used with permission. The Chrome browser is a trademarks of Google Inc., used with permission.

Mozilla and Firefox are registered trademarks of the Mozilla Foundation.

Red Hat is a registered trademarks of Red Hat, Inc. in the United States and other countries.

Ubuntu and Canonical are registered trademarks of Canonical Ltd.

All other trademarks and registered trademarks are the property of their respective holders.

Manual Name: ztC Endurance 3xx0, 5xx0, and 7xx0 Systems: User's Guide (VMware)

Part Number: R003C

Revision Number: 03

Product Release Number: Automated Uptime Layer with Smart Exchange Release 1.1.0.4

Publication Date: Friday, December 19, 2025

Penguin Solutions

5 Mill and Main Place, Suite 500

Maynard, Massachusetts 01754-2660

© 2025 Penguin Solutions (PENG) Ireland Limited. All rights reserved.

Table of Contents

ztC Endurance 3xx0, 5xx0, and 7xx0 Systems: User's Guide (VMware)	14
Part 1: ztC Endurance Hardware Guide	15
Chapter 1: Overview of Stratus ztC Endurance Systems	17
System Front	17
System Rear	18
System Ports	19
System CRU Modules	20
Compute Module	21
Memory in ztC Endurance Systems	22
Memory Components in Each Compute Module	23
Memory in ztC Endurance 31x0 Systems	24
Memory in ztC Endurance 51x0 Systems	25
Memory in ztC Endurance 71x0 Systems	26
Memory in ztC Endurance 9110 Systems	26
Storage Module	27
Disk Drives	28
Understanding Disk-Drive Numbering	28
Installing Additional Disk Drives	29
Important Considerations When Installing Disk Drives	30
I/O Module	30
PCIe Adapters	31
Understanding PCIe-Slot Numbering	32
Installing Additional PCIe Adapters	33
Important Considerations When Installing PCIe Adapters	33
Valid PCIe Configurations	34
PSUs	35

Peripheral Components	36
Chapter 2: Planning a Site for ztC Endurance Systems	37
Site Planning Checklist	38
Planning for ActiveService Network Connectivity	38
Planning for Network Connectivity	39
Planning AC Power	39
Planning Space for the System	39
Working with Other Groups	40
Electrical Power Planning	40
Redundant Power Sources	41
AC Power and HVAC Service Requirements	41
Electrical Power Connections	42
Power Cords	43
Grounding Requirements	45
Space Planning	45
Room Requirements	45
Planning for Cables	46
Communications Line Planning	47
Cabinet Requirements	47
Site Planning for Peripheral Components	50
Chapter 3: Installing and Connecting the ztC Endurance System Hardware	51
Safety Precautions	51
Warnings, Cautions, Notices, and Notes	52
Safety Notices	52
Environmental Warnings	57
Safety Precautions When Setting Up and Shipping Equipment	58
Power Cord Warnings and Cautions	58

Electrostatic Discharge (ESD) Warnings	61
Rack System Installation	62
Installing the System in a Cabinet	62
Numbering the Vertical Rails	64
Preparing the Support Rails for Installation	66
Attaching the Support Rails and Inserting the System	69
Completing the Hardware Set-up	72
To connect the system to AC power mains	76
Chapter 4: Operating the ztC Endurance System Hardware	83
Hardware Operation	83
Standby Power	83
System Power	84
Pressing the Power Button	84
Starting Up the System	85
Shutting Down the System	86
Enabling and Disabling Wake on LAN	88
Fan Speed	89
Troubleshooting the Hardware	89
Status LEDs	90
Using the ATTN LEDs to Diagnose Faults	97
Internal Disk Drive Problems and Solutions	99
Using the NMI Button	100
Chapter 5: Removing and Replacing System Components	101
General Servicing Information	101
Unpacking System Components	102
Storing System Components	103
Repacking System Components	103

Replacing System Components	104
General Safety Precautions	105
Preparing to Replace System Components	105
Using ESD Precautions	106
Observing Cautions and Warnings	106
Removing and Replacing a Compute Module	107
Replacing, Adding, and Upgrading Memory	110
Terminology for Memory Procedures	110
Important Cautions and Notes	110
Replacing DIMMs	111
Adding DIMMs	113
Removing and Replacing a Storage Module	116
Removing and Inserting a Disk Drive	118
Removing and Replacing an I/O Module	123
Removing and Installing a PCIe Adapter	126
Removing and Replacing a PSU and Power Cords	130
Chapter 6: Electrical Circuit and Wiring Information	135
Fault Protection Requirements	135
Grounding Considerations	135
Circuit Wiring Diagrams	136
Electrical Power Connectors	142
Part 2: ztC Endurance Software Guide	147
Chapter 7: System Software Installation and Upgrade (VMware)	149
Installing the System Software	149
Preparing to Install the System Software	149
Password and Installation Settings Printable Worksheet	161
Installing VMware ESXi and Deploying the Management VM	165

Overview	166
Downloading VMware vSphere Software	167
Configuring the BMC Network Settings.	179
Overview	181
Installing VMware ESXi and AUL-Smart Exchange	182
Post-Installation Tasks	185
Verifying the System Software Installation	186
Configuring System Management Options	188
Configuring the BMCs for Remote System Management	189
Configuring ESXi Host Client or vSphere Web Client for Remote System Management	189
Configuring SSH for Remote System Management	190
Configuring Network Interfaces	191
Upgrading the System Software	191
Chapter 8: System Software Administration (VMware)	209
Adding and Mirroring Data Disks	209
Updating Network IP Configuration Settings	210
Configuring VMware Components and Creating Virtual Machines	212
Considerations When Using VLANs	213
Installing Updates and Patches on the ESXi Host	213
Enabling ASNConnect	215
Checking Your Connection to ASNConnect	215
Installing ASNConnect on the ztC Endurance System	216
Installing a Custom Security Certificate	216
Changing Passwords on a ztC Endurance System	217
Chapter 9: Using the ztC Endurance Console	223
ztC Endurance Console	223
ztC Endurance Console Requirements	224

Compatible Internet Browsers	225
Logging In to the ztC Endurance Console for the First Time	225
Logging In to the ztC Endurance Console	226
Editing Your User Information	228
Dashboard Page	229
Understanding the ztC Endurance System Diagram	230
Alert Symbols	230
Resolving Outstanding Alerts on the Dashboard	231
Configuring the Mail Server	232
Hardware Page	233
Hardware States	233
Hardware Activity Types	234
Identifying a System or Component	238
Using Maintenance Mode	239
Shutting Down and Restarting a Compute Module	241
Volumes Page	242
Specifying Owner Information	243
Registering the System	243
Configuring Users	248
Managing User Accounts	249
Alert History Page	250
Support Logs Page	251
Creating a Diagnostic File	252
Deleting a Diagnostic File	252
Configuring e-Alerts	253
Managing SNMP	254
Configuring SNMP Settings	254

Managing Firewall Settings	255
Obtaining System Information with snmptable	261
Configuring OPC Settings	264
Displaying OPC Output	267
Configuring Remote Support Settings	271
To configure ASN "heartbeat" alarms	274
Configuring Internet Proxy Settings	274
Upgrade Kits Page	275
Upgrade Kit States	275
Chapter 10: Overview of the BMC Web Console	277
Prerequisites for Using the BMC Web Console	277
Required Browser Settings	278
Additional Requirements	278
Connecting to the BMC Web Console	278
Logging In to the BMC Web Console	279
Accessing Documentation from the BMC Web Console	280
Configuring DNS Settings in the BMC Web Console	280
To specify the DDNS method in the BMC Web Console	281
Unsupported BMC Web Console Features	281
Browser Functions to Avoid	281
Avoid Using Caps Lock Key in KVM	281
Do Not Use BMC Web Console to Power Off Running System	281
Part 3: ztC Endurance Supporting Documents	283
Chapter 11: Release Notes: Automated Uptime Layer with Smart Exchange Release	
1.1.0.4 (VMware)	285
New Features and Enhancements	285
Support for Upgrading	285

Stratus Technologies is now part of Penguin Solutions	285
Supported Systems	286
Bug Fixes	286
BeyondTrust® Backward-Compatibility Support	286
Important Considerations	286
Do Not Update the Ubuntu System Software	286
Important Information about VMware License Activation	286
Do Not Change BIOS Settings	286
Known Issues	287
Do Not Use BIOS to Disable Wake On LAN	287
Long Network Delays with PCIe Adapter During I/O Faults	287
Manual Reboot of Standby Compute Module on Which install.sh Is Running Required to Register Hostname with DNS Server	287
Smart Exchange May Cause USB Driver to Issue Spurious Warnings in vmkernel.log File	287
Remove Existing ASNConnect Data When Installing Replacement Compute Module	287
Run bmc_config or net_config Script Again If Network Reconfiguration Fails	288
Install ASNConnect After You Replace a Compute Module	288
System Reports a PSU Error When Power State Changes From No Power to Powered On	288
IPv6 Must Be Enabled in BMC Web Console	288
X710 Adapter Link Still Active After Bringing Down Adapter	289
Reconfiguring System from Static IPv6 Addresses to Dynamic IPv4 Addresses	289
Spurious PSU Fan Alert After PSU Powers Up	289
Delete Upgrade Files If Management VM Lacks Disk Space	290
Resolve Active Alerts Before Upgrading System Software	290
Enter Only One DNS Server During Installation	290
Do Not Use Certain Special Characters in BMC Password	290
Reporting Error in zen_verify.sh Script	291

Management VM Must Be Located on Local Boot Disk	291
strmgmtuser User Appearing in Log Files	291
Accessing Stratus Knowledge Base Articles	291
Getting Help	291
Chapter 12: System Reference Information	293
System Specifications	293
Getting Help	299
Using the BIOS Setup Utility	301
Important Considerations When Using the BIOS Setup Utility	301
REST API	302
Accessing the REST API Documentation	302
Logging In for REST API Testing	302
End-User License Agreements and Warranty	304
Glossary	305

ztC Endurance 3xx0, 5xx0, and 7xx0 Systems: User's Guide (VMware)

The ztC Endurance 3xx0, 5xx0, and 7xx0 Systems: User's Guide (VMware) (R003C) describes ztC Endurance systems, how to deploy them, and how to use them.

Part 1: [ztC Endurance Hardware Guide](#) describes the ztC Endurance hardware. It includes:

- "Overview of Stratus ztC Endurance Systems" on page 17
- "Planning a Site for ztC Endurance Systems" on page 37
- "Installing and Connecting the ztC Endurance System Hardware" on page 51
- "Operating the ztC Endurance System Hardware" on page 83
- "Removing and Replacing System Components" on page 101
- "Electrical Circuit and Wiring Information" on page 135

Part 2: [ztC Endurance Software Guide](#) describes the ztC Endurance software. It includes:

- "System Software Installation and Upgrade (VMware)" on page 149
- "System Software Administration (VMware)" on page 209
- "Using the ztC Endurance Console" on page 223
- "Overview of the BMC Web Console" on page 277

Part 3: [ztC Endurance Supporting Documents](#) describes the ztC Endurance supporting documents. It includes:

- [Release Notes](#)
- "System Reference Information" on page 293
- "System Specifications" on page 293

Next Steps:

To install the system hardware, see "[Installing and Connecting the ztC Endurance System Hardware](#)" on page 51.

To install the system software, see "[Installing the System Software](#)" on page 149.

Part 1: ztC Endurance Hardware Guide

The ztC Endurance Hardware Guide discusses the following topics:

- ["Overview of Stratus ztC Endurance Systems" on page 17](#)
- ["Planning a Site for ztC Endurance Systems" on page 37](#)
- ["Installing and Connecting the ztC Endurance System Hardware" on page 51](#)
- ["Operating the ztC Endurance System Hardware" on page 83](#)
- ["Removing and Replacing System Components" on page 101](#)
- ["Electrical Circuit and Wiring Information" on page 135](#)

Related Topics

- ["ztC Endurance Software Guide" on page 147](#)
- ["ztC Endurance Supporting Documents" on page 283](#)

1

Chapter 1: Overview of Stratus ztC Endurance Systems

A Stratus ztC Endurance system consists of a system chassis that you install on rails in a cabinet. At the front and rear of the system chassis, you view LEDs and access modules for maintenance. Each module is a customer-replaceable unit (CRU) that you can remove and replace.

Read the following topics to familiarize yourself with your ztC Endurance system:

- ["System Front" on page 17](#)
- ["System Rear" on page 18](#)
- ["System CRU Modules" on page 20](#)
- ["Peripheral Components" on page 36](#)
- ["Planning a Site for ztC Endurance Systems" on page 37](#)

Next Steps

When you are familiar with the system, install the system hardware as described in ["Installing and Connecting the ztC Endurance System Hardware" on page 51](#).



Note: As you read through the installation topics, the sections labeled **Next Steps** provide links that help you move to the next logical step in a procedure.

System Front

The front of the system consists of two [storage modules](#) and two [compute modules](#). Each storage module and each compute module is a [CRU module](#). The system front also includes the control-panel ear on the right and a blank ear on the left. See [Figure 1-1](#).

For more information, see:

- "System CRU Modules" on page 20 for information about the compute module (which contains [DIMMs](#)), and the storage module (which contains [disk drives](#))
- "Status LEDs" on page 90 for information about the LEDs on the control-panel ear, the storage module, and the compute module
- "System Power" on page 84 for information about the power button on the control-panel ear
- "Installing and Connecting the ztC Endurance System Hardware" on page 51 for information about installing and connecting the hardware
- "System Specifications" on page 293 for detailed specifications about the system and its components

Figure 1-1: System Front

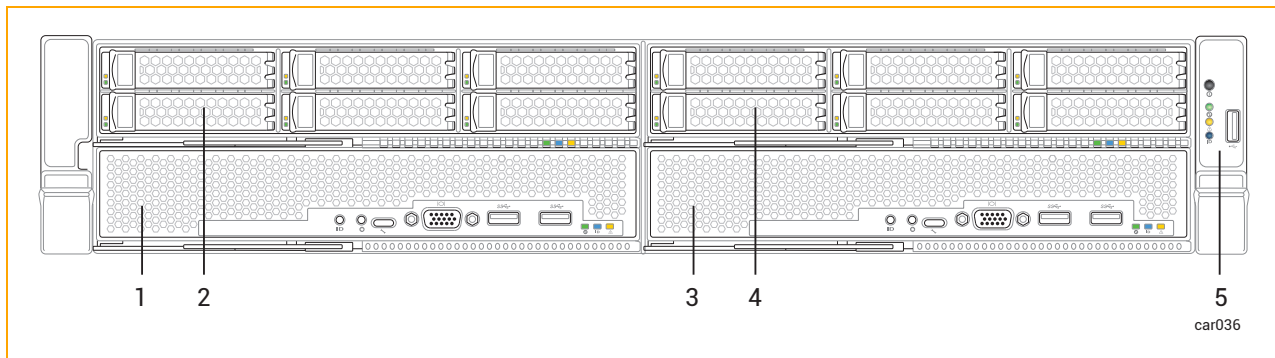

1	Compute module A	4	Storage module B
2	Storage module A	5	Control-panel ear
3	Compute module B		



Note: The left ear contains a QR code that links to ztC Endurance Release Notes and documentation at <https://ztcendurancedoc.stratus.com>.

Related Topics

- "Planning a Site for ztC Endurance Systems" on page 37
- "System Reference Information" on page 293

System Rear

The rear of the system consists of two power-supply units (PSUs) and two I/O modules. Each PSU and each I/O module is a [CRU module](#). See [Figure 1-2](#).

For more information, see:

- ["System CRU Modules"](#) on page 20 for information about the I/O modules and PSUs
- ["Status LEDs"](#) on page 90 for information about the LEDs on the I/O module
- ["Installing and Connecting the ztC Endurance System Hardware"](#) on page 51 for information about installing and connecting the hardware
- ["System Specifications"](#) on page 293 for detailed specifications about the system and its components

Figure 1-2: System Rear

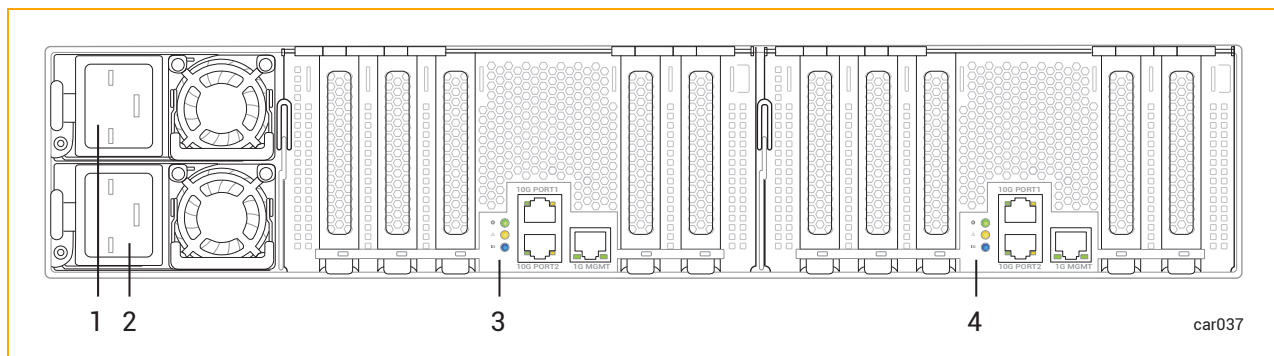

1	Power-supply unit (PSU) A	3	I/O module A
2	Power-supply unit (PSU) B	4	I/O module B

Related Topics

- ["Planning a Site for ztC Endurance Systems"](#) on page 37
- ["System Reference Information"](#) on page 293

System Ports

Ports are located at the front ([Figure 1-3](#)) and rear ([Figure 1-4](#)) of the system.



Note: The USB 2.0 port on the control-panel ear is the only front port that stays with the active compute module through a Smart Exchange operation. That is, after the active compute module becomes the standby module, the USB 2.0 port automatically connects to the new active compute module.

Figure 1-3: System Ports: Front

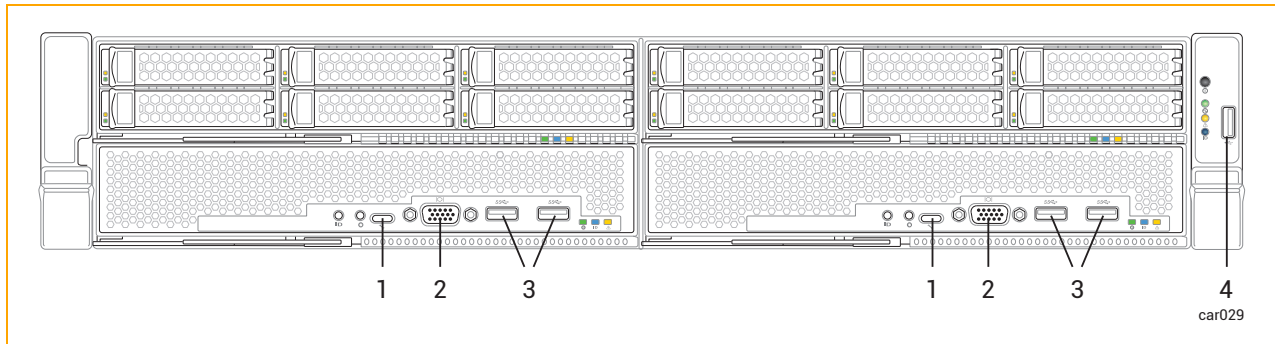

1	Debug ports (2)	3	USB 3.0 ports (4)
2	VGA (monitor port) (2)	4	USB 2.0 port (1)

Figure 1-4: System Ports: Rear

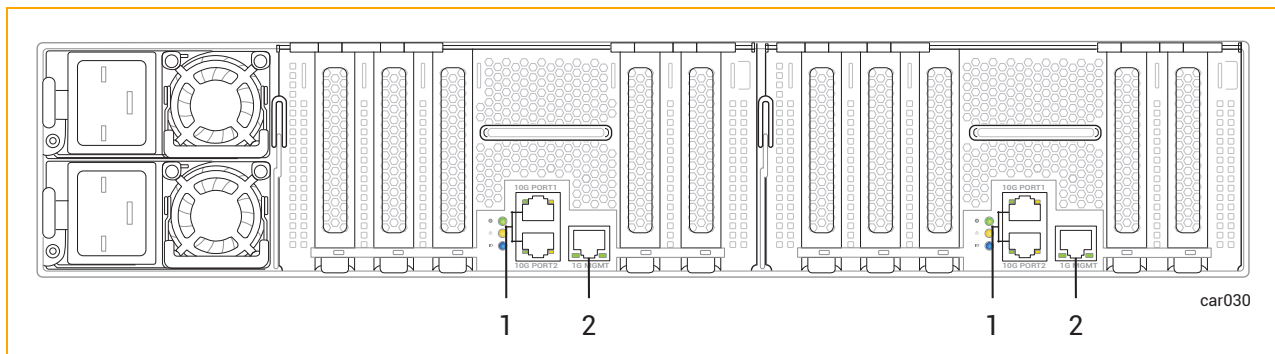

1	10G ports (4)
2	1G MGMT ports (2)

Related Topics

- ["System Front" on page 17](#)
- ["System Rear" on page 18](#)

System CRU Modules

A ztC Endurance system contains customer-replaceable unit (CRU) modules, which allow on-site personnel to easily remove and replace faulty components with minimal training or tools. These CRU modules are:

- [Compute module](#) and its [DIMMs](#)
- [Storage module](#) and its [disk drives](#)

- [I/O module](#) and its [PCIe adapters](#)
- [PSUs](#)

Related Topics

- "System Front" on page 17
- "System Rear" on page 18
- "Removing and Replacing System Components" on page 101
- "System Specifications" on page 293

Compute Module

A ztC Endurance system contains two compute modules: compute module A and compute module B. [Figure 1-1](#) shows the location of each compute module in a system.

A compute module is a [2U](#) component with processors, DIMMs, BIOS, BMC, fans, and other technology to boot and run the ztC Endurance system.

[Figure 1-5](#) shows an individual compute module. Each compute module provides:

- Ports, including one VGA port and two USB 3.0 ports. See "[System Ports](#)" on page 19. (The UART USB-C connector, known as the debug port, is used only by Penguin Solutions Customer Service for debugging.)
- An ID button, which activates the ID LED on the control-panel ear. See "[Status LEDs](#)" on page 90.
- An NMI button. See "[Using the NMI Button](#)" on page 100.
- Status LEDs, which indicate the status of the compute module. See "[Status LEDs](#)" on page 90.
- DIMMs, which provide the system's random-access memory (RAM). See "[Replacing, Adding, and Upgrading Memory](#)" on page 110.

Figure 1-5: Compute Module

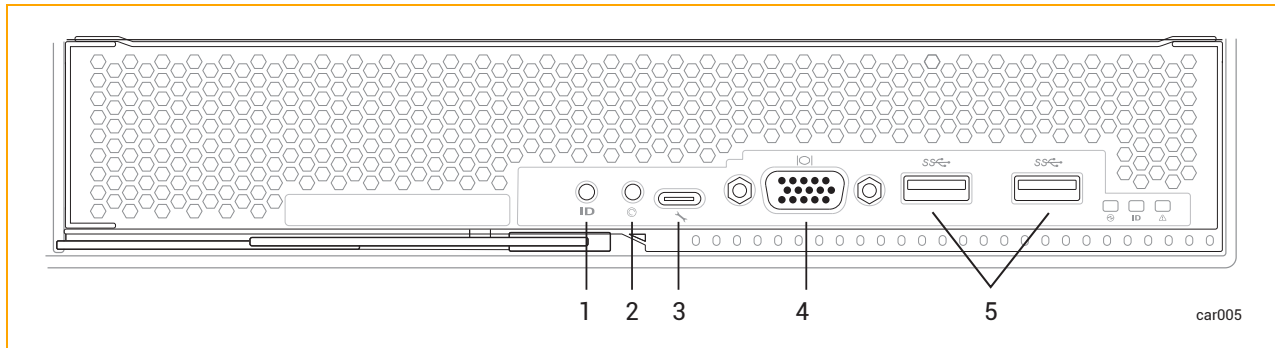

1	ID button	4	VGA port
2	NMI button	5	USB 3.0 port (x2)
3	Debug port		

Related Topics

- ["System Front" on page 17](#)
- ["Planning a Site for ztC Endurance Systems" on page 37](#)
- ["Removing and Replacing a Compute Module" on page 107](#)
- ["System Specifications" on page 293](#)

Memory in ztC Endurance Systems

Read this topic before you add or replace dual in-line memory modules (DIMMs) in a ztC Endurance system.

Cautions:



1. Penguin Solutions supports only the configurations described in this topic. Unsupported configurations may lead to system instability or failure.
2. For ztC Endurance systems operating in the low-voltage range, total memory must not exceed 256 GB. See ["System Specifications" on page 293](#) for more information about low-voltage systems.

Précautions:

1. Penguin Solutions ne prend en charge que les configurations décrites dans ce sujet. Les configurations non prises en charge peuvent entraîner une instabilité ou une défaillance du système.
2. Pour les ztC Endurance systèmes fonctionnant dans la gamme basse tension, la mémoire totale ne doit pas dépasser 256 Go. Consultez "[System Specifications](#)" on [page 293](#) pour plus d'informations sur les systèmes basse tension.

Memory Components in Each Compute Module

Table 1-1 lists the memory components in each compute module.



Notice: In a ztC Endurance 31x0 system, the eight DIMM slots next to the empty socket cannot contain DIMMs.

Table 1-1: Memory Components

Model	Processors	Sockets	DIMM Slots	Minimum Number of DIMMs	Maximum Number of DIMMs
31x0	1	2	16	1	4
51x0	2	2	16	2	8
71x0	2	2	16	4	16
9110	2	2	16	16	16

Figure 1-6 shows the area of a compute module that contains memory components. Specifically, the figure shows the two processors, each installed in a socket, and the location of each DIMM slot.

Figure 1-6: Location of Memory Components in a Compute Module

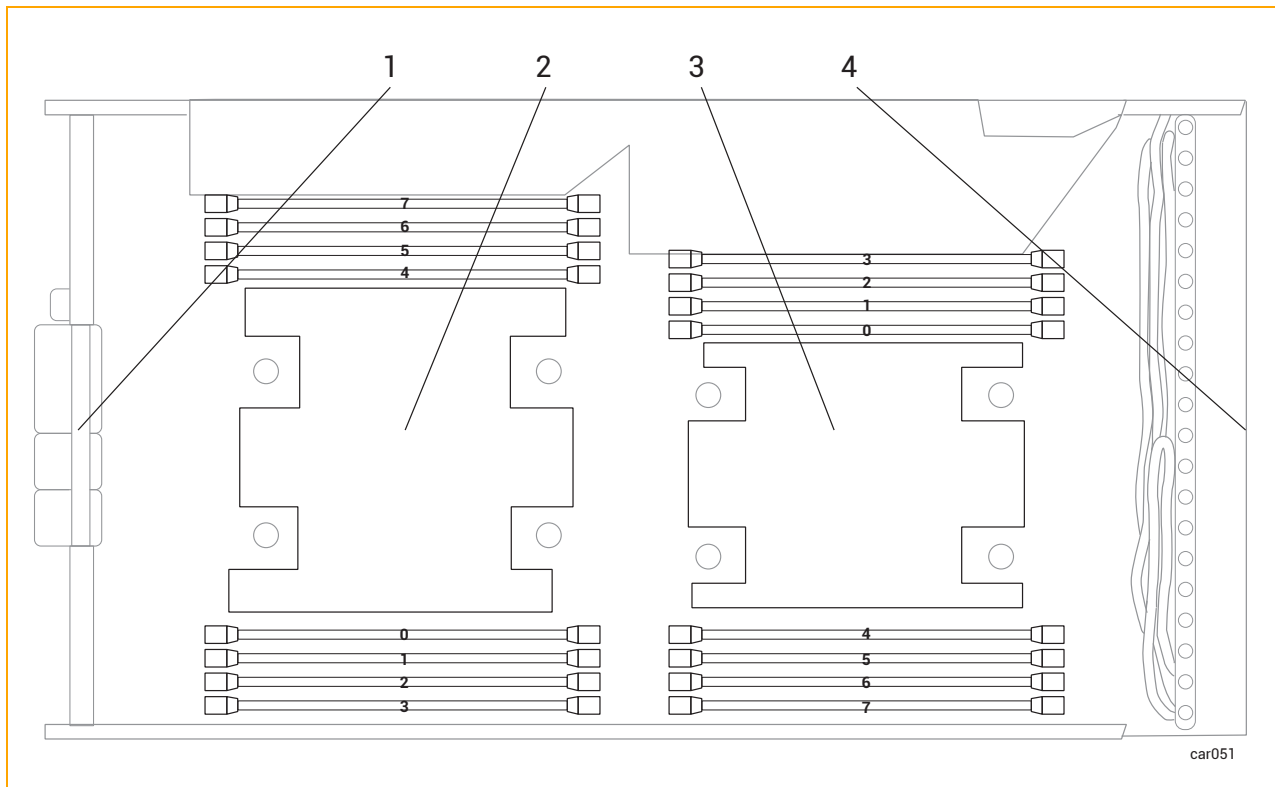

1	Rear of compute module	3	Processor 1
2	Processor 0	4	Front of compute module

Memory in ztC Endurance 31x0 Systems

Table 1-2 shows a representation, starting from the front of the compute module, of DIMM locations for supported ztC Endurance 31x0 configurations. An "X" indicates the presence of a DIMM; all other DIMM slots are empty.

 **Note:** Table 1-2 does not show the DIMM slots that are next to the empty socket.

Table 1-2: Memory in ztC Endurance 31x0 Systems

	ZEN31x0-64	ZEN31x0-128	ZEN31x0-256
Slot 7			

	ZEN31x0-64	ZEN31x0-128	ZEN31x0-256
Slot 6		X	X
Slot 5			
Slot 4			X
Processor 0			
Slot 0	X	X	X
Slot 1			
Slot 2			X
Slot 3			

Memory in ztC Endurance 51x0 Systems

Table 1-3 shows a representation, starting from the front of the compute module, of DIMM locations for supported ztC Endurance 51x0 configurations. An "X" indicates the presence of a DIMM; all other DIMM slots are empty.

Table 1-3: Memory in ztC Endurance 51x0 Systems

	ZEN51x0-128			ZEN51x0-256		ZEN51x0-512	
Slot 7	Slot 3						
Slot 6	Slot 2			X		X	X
Slot 5	Slot 1						
Slot 4	Slot 0		X		X	X	X
Processor 0	Processor 1						
Slot 0	Slot 4	X		X		X	X
Slot 1	Slot 5						
Slot 2	Slot 6				X	X	X
Slot 3	Slot 7						

Memory in ztC Endurance 71x0 Systems

Table 1-4 shows a representation, starting from the front of the compute module, of DIMM locations for supported ztC Endurance 71x0 configurations. An "X" indicates the presence of a DIMM; all other DIMM slots are empty.

Table 1-4: Memory in ztC Endurance 71x0 Systems

	ZEN71x0-256			ZEN71x0-512		ZEN71x0-1024	
Slot 7	Slot 3					X	X
Slot 6	Slot 2	X		X	X	X	X
Slot 5	Slot 1					X	X
Slot 4	Slot 0		X	X	X	X	X
Processor 0	Processor 1						
Slot 0	Slot 4	X		X	X	X	X
Slot 1	Slot 5					X	X
Slot 2	Slot 6		X	X	X	X	X
Slot 3	Slot 7					X	X

Memory in ztC Endurance 9110 Systems

Table 1-5 shows a representation, starting from the front of the compute module, of DIMM locations for supported ztC Endurance 9110 configurations. An "X" indicates the presence of a DIMM.

Table 1-5: Memory in ztC Endurance 9110 Systems

	ZEN9110-1024		
Slot 7	Slot 3		X
Slot 6	Slot 2		X
Slot 5	Slot 1		X
Slot 4	Slot 0		X

		ZEN9110-1024	
Processor 0	Processor 1		
Slot 0	Slot 4	X	X
Slot 1	Slot 5	X	X
Slot 2	Slot 6	X	X
Slot 3	Slot 7	X	X

Related Topics

- ["Replacing, Adding, and Upgrading Memory" on page 110](#)
- ["Compute Module" on page 21](#)
- ["Hardware Page" on page 233](#)

Storage Module

A ztC Endurance system contains two storage modules: storage module A and storage module B. [Figure 1-1](#) shows the location of each storage module in a system.

[Figure 1-7](#) shows an individual storage module. Each storage module provides:

- Six slots for disk drives. For additional information about disk drives, see:
 - ["System Specifications" on page 293](#) for information about the supported disk drives.
 - ["Disk Drives" on page 28](#) for information about disk-drive configuration and numbering.
 - ["Internal Disk Drive Problems and Solutions" on page 99](#) for troubleshooting information.
 - ["Removing and Inserting a Disk Drive" on page 118](#) for maintenance information.
- Status LEDs, which indicate the status of the storage module. See ["Status LEDs" on page 90](#).

Figure 1-7: Storage Module

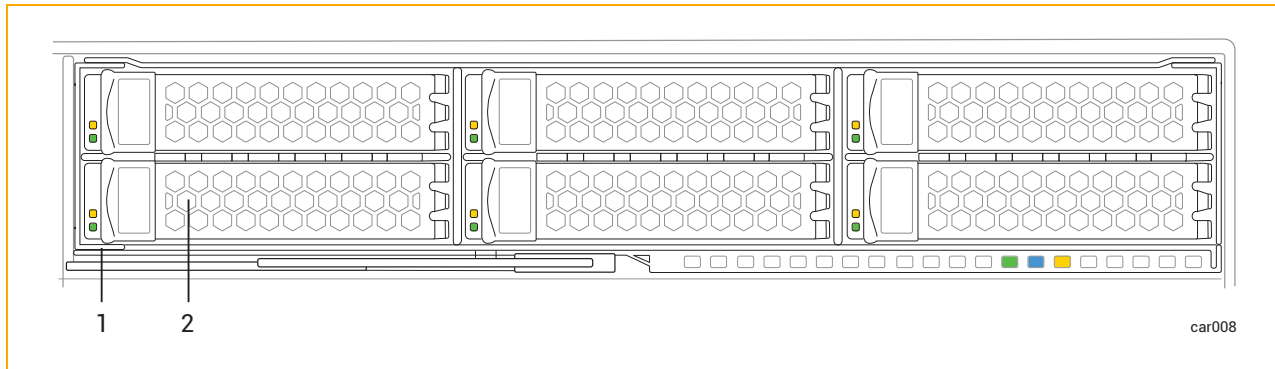

- | | |
|---|--------------------------------------|
| 1 | Storage module |
| 2 | Disk drive slot with disk drive (x6) |

Related Topics

- ["System Front" on page 17](#)
- ["Planning a Site for ztC Endurance Systems" on page 37](#)
- ["Removing and Replacing a Storage Module" on page 116](#)

Disk Drives

When you receive your system from the manufacturer, disk drives that were ordered at the same time the system was ordered are already installed. To install additional disk drives, be sure to read ["Installing Additional Disk Drives" on page 29](#) and ["Important Considerations When Installing Disk Drives" on page 30](#) before you read ["Removing and Inserting a Disk Drive" on page 118](#).

See ["System Specifications" on page 293](#) for information about the supported disk drives.

Understanding Disk-Drive Numbering

Storage module A and storage module B each contain six disk-drive slots, for a total of 12 per system. The slots are labeled 1 through 6 on each storage module, as shown in [Figure 1-8](#).

Figure 1-8: Disk-Drive Slot Numbering

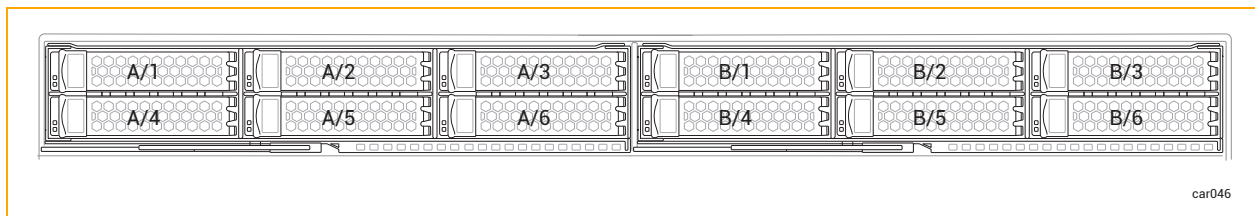

The physical disk-drive slot numbering corresponds to the software numbering. For example, disk-drive slot 1 corresponds to slots A/1 and B/1 in the software, disk-drive slot 2 corresponds to slots A/2 and B/2, and so on.

You can view information about the disk drives from "[Hardware Page](#)" on [page 233](#) of the ztC Endurance console and from your operating-system software.

Installing Additional Disk Drives

Install additional disk drives in your system in the order shown in [Table 1-6](#). For example, if you are adding two disks to a system that already contains disks in slots A/1 and B/1, install the two additional disks in slots A/2 and B/2, for a total of four disks in the system.

Table 1-6: Disk-Drive Installation Order

Number of Disks	Storage Module A	Storage Module B
2	Slot 1	Slot 1
4	Slots 1, 2	Slots 1, 2
6	Slots 1, 2, 3	Slots 1, 2, 3
8	Slots 1, 2, 3, 4	Slots 1, 2, 3, 4
10	Slots 1, 2, 3, 4, 5	Slots 1, 2, 3, 4, 5
12	Slots 1, 2, 3, 4, 5, 6	Slots 1, 2, 3, 4, 5, 6

Important Considerations When Installing Disk Drives

Before you install disk drives, consider the following:

- The boot drive must be installed in slot 1.
- A storage module can contain different disk-drive models. However, you must install identical disk-drive models in matching storage module A and B slots. For instance, if you install a 1.6 TB disk drive in slot 1 of storage module A, you must install a 1.6 TB disk drive in slot 1 of storage module B.
- Make sure all disk drives are correctly inserted as described in ["To insert a disk drive" on page 119](#).

Related Topics

- ["Removing and Inserting a Disk Drive" on page 118](#)
- ["Internal Disk Drive Problems and Solutions" on page 99](#)
- ["Storage Module" on page 27](#)

I/O Module

A ztC Endurance system contains two I/O modules: I/O module A and I/O module B. [Figure 1-2](#) shows the location of each I/O module in a system.

[Figure 1-9](#) shows an individual I/O module. Each I/O module provides:

- Ethernet ports. See ["System Ports" on page 19](#).
 - One 1G (RJ45) port for an out-of-band management network
 - Two 10G (RJ45) ports
- Status LEDs, which indicate the status of the I/O module. See ["Status LEDs" on page 90](#).
- Five PCIe 4.0 slots for half-height PCIe adapters. For additional information about PCIe adapters, see:
 - ["System Specifications" on page 293](#) for information on the supported PCIe adapters.
 - ["Communications Line Planning" on page 47](#) for information on the communications lines.
 - ["PCIe Adapters" on page 31](#) for information about PCIe-adapter configuration and numbering.
 - ["Removing and Installing a PCIe Adapter" on page 126](#) for maintenance information.

Figure 1-9: I/O Module

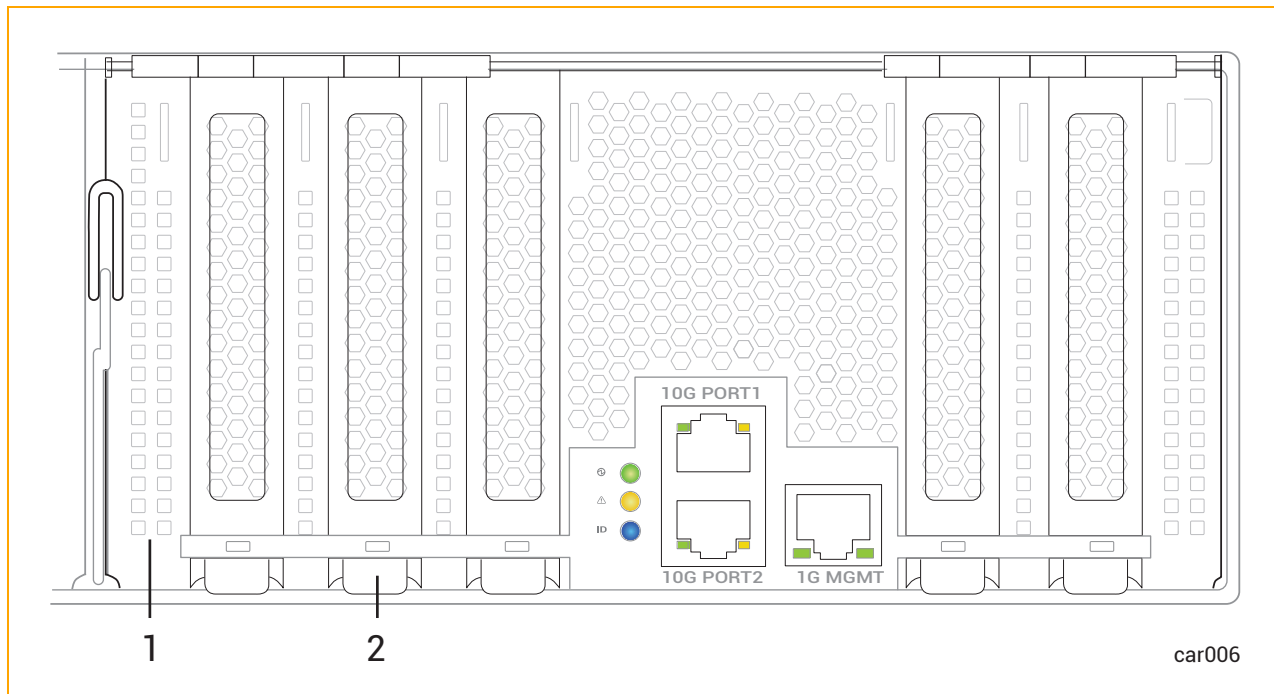

1	I/O module
2	PCIe adapter slot (x5)

Related Topics

- ["System Rear" on page 18](#)
- ["Planning a Site for ztC Endurance Systems" on page 37](#)
- ["Removing and Replacing an I/O Module" on page 123](#)
- ["Hardware Page" on page 233](#)
- ["System Reference Information" on page 293](#)
- ["System Specifications" on page 293](#)

PCIe Adapters

When you receive your system from the manufacturer, PCIe adapters that were ordered at the same time the system was ordered arrive pre-installed. To install additional PCIe adapters, be sure to read the following before you read ["Removing and Installing a PCIe Adapter" on page 126](#)

- ["Understanding PCIe-Slot Numbering" on page 32](#)
- ["Installing Additional PCIe Adapters" on page 33](#)

- ["Important Considerations When Installing PCIe Adapters"](#) on page 33
- ["Valid PCIe Configurations"](#) on page 34

See ["System Specifications"](#) on page 293 for information about the supported PCIe adapters.

Understanding PCIe-Slot Numbering

I/O module A and I/O module B each contain five PCIe adapter slots, for a total of ten per system. The slots are labeled 1 through 5 on each I/O module, as shown in [Figure 1-10](#). Each I/O module also contains an embedded dual-port 10G adapter.

Figure 1-10: PCIe-Adapter Physical Slot Numbering

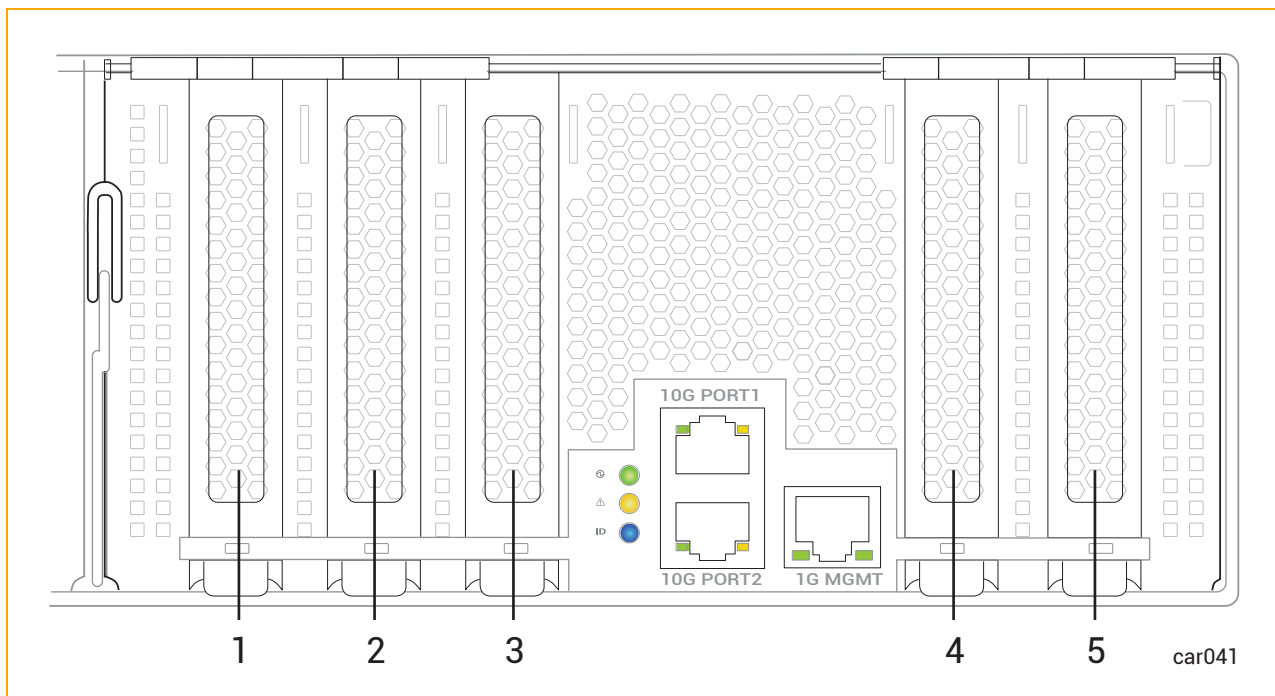

1	PCIe slot 1	4	PCIe slot 4
2	PCIe slot 2	5	PCIe slot 5
3	PCIe slot 3		

You can view information about the PCIe adapters from ["Hardware Page"](#) on page 233 of the ztC Endurance console and from your operating-system software.

- For PCIe slots 1 through 5, the physical PCIe slot numbering corresponds to the software numbering. For example, PCIe slot 1 corresponds to slots A/1 and B/1 in the software, PCIe slot

2 corresponds to slots A/2 and B/2, and so on.

- The embedded dual-port 10G adapters appear in the software as slots A/6 and B/6.

Installing Additional PCIe Adapters

Install additional PCIe adapters in your system in the order shown in [Table 1-7](#). For example, if you are adding two PCIe adapters to a system that already contains PCIe adapters in slots A/1 and B/1, install the two additional PCIe adapters in slots A/2 and B/2, for a total of four PCIe adapters in the system.

Table 1-7: PCIe-Adapter Installation Order

Number of Adapters	I/O Module A	I/O Module B
2	Slot 1	Slot 1
4	Slots 1, 2	Slots 1, 2
6	Slots 1, 2, 3	Slots 1, 2, 3
8	Slots 1, 2, 3, 4	Slots 1, 2, 3, 4
10	Slots 1, 2, 3, 4, 5	Slots 1, 2, 3, 4, 5

Important Considerations When Installing PCIe Adapters

Before you install PCIe adapters, consider the following:

- Use only PCIe adapters approved by Penguin Solutions. Before approving a PCIe adapter, Penguin Solutions thoroughly tests it to make sure that it interacts properly with ztC Endurance systems, including I/O redundancy with a duplexed partner if an active PCIe adapter or I/O module fails or is removed from service. Customers who have attempted to use inadequately tested PCIe adapters in their systems have frequently experienced problems that proved difficult to isolate and diagnose and resulted in delayed projects.
- Thoroughly test any new PCIe adapter, including adapters sold or approved by Penguin Solutions, with your applications in a test environment before using it in a production environment.
- An I/O module can contain different PCIe adapter models. However, you must install identical PCIe adapter models in matching I/O module A and B slots. For instance, if you install an Intel X550-T2 PCIe adapter in slot 1 of I/O module A, you must install an Intel X550-T2 PCIe adapter in slot 1 of I/O module B.

Valid PCIe Configurations

Table 1-8 describes valid PCIe adapter configurations for each ztC Endurance I/O module. To interpret the table, read it from left to right.



Note: Contact your authorized Penguin Solutions service representative if you have questions about the models supported by your ztC Endurance system.

Table 1-8: Valid PCIe Adapter Configurations for ESXi ztC Endurance Systems

ztC Endurance Model	Maximum Number of Each Adapter Type Allowed Per I/O Module			Maximum Number of Total Adapters Allowed Per I/O Module
	XXV710 Dual 25 Gbps	QLE2770 Single 32 Gbps	X550 or X710 Dual 10 Gbps	
Low-voltage 31x0	Not supported	0	3	3
		1	1	2
Low-voltage 51x0	Not supported	0	3	3
		1	1	2
31x0	Not supported	1	3	3
51x0	2	2	3	3
71x0	2	2	3	3
9110	2	2	3	3

Related Topics

- ["Removing and Installing a PCIe Adapter" on page 126](#)
- ["I/O Module" on page 30](#)
- ["Hardware Page" on page 233](#)
- ["System Specifications" on page 293](#)

PSUs

A ztC Endurance system contains two power supply units (PSUs): PSU A and PSU B. [Figure 1-2](#) shows the location of each PSU in a system.

[Figure 1-11](#) shows an individual PSU. Each PSU includes a status LED, which indicates the status of the unit. See ["Status LEDs"](#) on page 90.

Figure 1-11: Power Supply Unit (PSU)

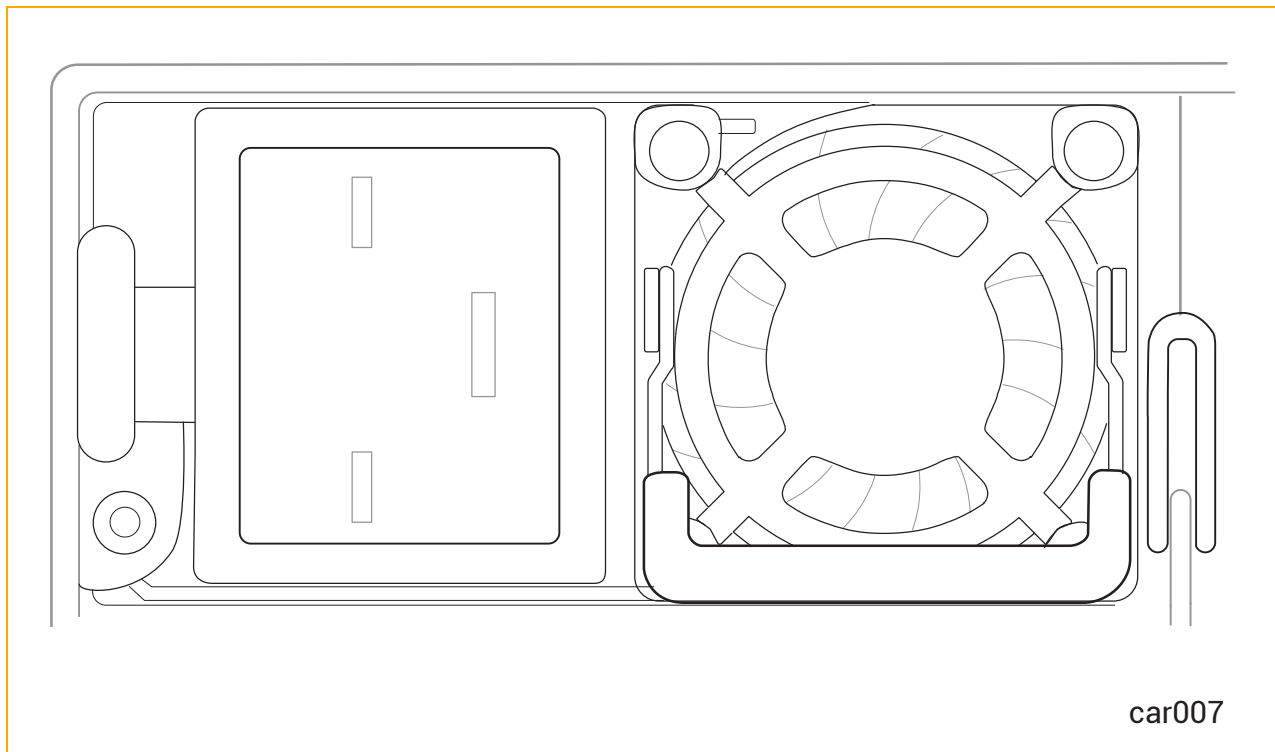

Related Topics

- ["System Rear"](#) on page 18
- ["Planning a Site for ztC Endurance Systems"](#) on page 37
- ["Removing and Replacing a PSU and Power Cords"](#) on page 130
- ["System Power"](#) on page 84
- ["Standby Power"](#) on page 83
- ["System Reference Information"](#) on page 293
- ["System Specifications"](#) on page 293

Peripheral Components

Penguin Solutions supplies a mouse and keyboard for your ztC Endurance system.

For site-planning information for the mouse and keyboard, see "[Site Planning for Peripheral Components](#)" on page 50.

For information about connecting the mouse and keyboard, see [Connecting Peripherals](#).

2

Chapter 2: Planning a Site for ztC Endurance Systems

Notes:



1. See "Safety Notices" on page 52 for a list of important safety notices that you should review as part of your site planning.
2. All regulatory notices are provided in *Compliance Information for Stratus Products (R002G)*, which is available on StrataDOC at https://stratadoc.stratus.com/compliance_info/Compliance_Information_for_Stratus_Products.htm

Site planning for ztC Endurance systems includes:

- "Site Planning Checklist" on page 38

Reviewing the site-planning checklist for a summary of questions you might need to consider when planning for the installation of a ztC Endurance system.

- "Electrical Power Planning" on page 40

Providing electrical power sources that meet the requirements of the system and optional components, including the purchase of user-supplied power-distribution units (PDUs) and uninterruptible power supplies (UPSes).

- "Space Planning" on page 45

Providing adequate space for the system or cabinet and for a desk or table to accommodate components outside a cabinet. Also providing enough space for servicing the systems and components.

Providing an environment that meets the system's requirements for ambient temperature and air quality.

- ["Communications Line Planning" on page 47](#)

Providing sufficient network lines and planning the location of the system and external components to accommodate the lengths of the connecting cables.

- ["Cabinet Requirements" on page 47](#)

Providing a cabinet that meets the system's requirements and provides sufficient space for all components, including user-supplied PDUs and UPSes.

- ["Site Planning for Peripheral Components" on page 50](#)

Providing a monitor, keyboard, and mouse (if applicable) that meet the system's requirements.

Providing for the electrical, cooling, power, and space needs of any peripheral components.

For additional documentation related to the ztC Endurance system, see the StrataDOC (ztC Endurance Version) page at <https://ztcendurancedoc.stratus.com>.

During the site planning and preparation processes, work closely with your facilities group or contractor to determine space, power, and environmental requirements. Enlist their help to provide a suitable location with sufficient alternating current (AC) power, heating, ventilation, and air conditioning (HVAC) capabilities, and network and telephone connections.

If the system is covered by a service agreement and you need help with site planning, contact your authorized Penguin Solutions service representative. If you have a contract with your authorized Penguin Solutions service representative to install the system, contact them after you have prepared the installation site and moved the system to the site. For more information about your authorized Penguin Solutions service representative, see ["Getting Help" on page 299](#) or the **Penguin Solutions Customer Service** page at <https://www.penguinolutions.com/en-us/support>.

See ["System Specifications" on page 293](#) for the specifications of the ztC Endurance systems.

Site Planning Checklist

Referring to the information in this document, answer the following questions:

Planning for ActiveService Network Connectivity

- Will the ztC Endurance system connect to the Stratus ActiveService Network (ASN), allowing the system to automatically report problems to your authorized Penguin Solutions service representative?

- To allow connections to the ASN to report system health and events on your system, can you connect at least one pair of partnered Ethernet ports, one from each I/O module in the system, to a network that has Internet access?
- To optionally enable Penguin Solutions Customer Service or your authorized Penguin Solutions service representative to access the system to remotely diagnose, troubleshoot, and resolve problems online, can you connect the Ethernet port of the Baseboard Management Controller (BMC) in each module to a network that has Internet access? (The BMCs can communicate with the ASN even when the host operating system is not running or is unresponsive.)

Planning for Network Connectivity

- Each ztC Endurance system contains four embedded 10-gigabit Ethernet (GbE) ports, two in each I/O module, for connection to business networks. In addition, each system contains two embedded 1GbE ports that are dedicated to the BMCs for out-of-band management. How many embedded Ethernet ports will you connect to a network, and how many optional, non-embedded Ethernet PCIe adapters will you need to add to provide additional Ethernet bandwidth?
- How many embedded or non-embedded Ethernet ports in the system will require access to the Internet?

Planning AC Power

- Will you provide power to both sides of the system through a pair of PDUs?
- Will you protect the system power with a UPS?
- What optional components will you use?
- What are the AC power requirements of the system, including all optional components?
- What are the lengths and types of the power cords that are provided for the PDUs or system, and optional components?
- What type of AC receptacles do you need to provide?
- Is the AC power service wired properly?

Planning Space for the System

- If applicable, provide a table or desk for the monitor, keyboard, and mouse.
- Will the system and any external components fit where you plan to place them?
- What is the height of the cabinet you will use, and what is the total height of the systems and components that will be installed in the cabinet? Will the items fit into the cabinet? What components will be located outside the cabinet?

- What are the lengths and types of the interface and communications cables that will connect to the system?
- Have you created a sketch of how you plan to arrange the system at the installation site? Consider the available cable lengths, the placement of external devices, and the location of network and voice communication connections.

On the sketch, show the following:

- Location of the system and its external components
- Power cords, and telephone and interface cables
- Locations of AC power receptacles, Ethernet jacks, switches, and hubs



Note: Make sure that all cords and cables are long enough to reach between their respective components and connectors. Route all cables out of the way of foot traffic.

Working with Other Groups

- Have you provided your facilities group and contractors with the sketch of how you plan to arrange the system and copies of the following?
 - ["Redundant Power Sources" on page 41](#)
 - ["AC Power and HVAC Service Requirements" on page 41](#)
 - ["Electrical Circuit and Wiring Information" on page 135](#)
 - Any notes you have about site planning
- Have you reviewed and discussed the requirements with the facilities personnel and contractors to ensure that all site modifications are understood and implemented?

If you have any questions about the number and types of components, contact your Penguin Solutions account representative or distributor.

Electrical Power Planning

For information about planning appropriate AC electrical power for the system and its peripheral components, see:

- ["Redundant Power Sources" on page 41](#)
- ["AC Power and HVAC Service Requirements" on page 41](#)
- ["Electrical Power Connections" on page 42](#)

- ["Power Cords" on page 43](#)
- ["Grounding Requirements" on page 45](#)

Redundant Power Sources

ztC Endurance systems require at least two separate and independent AC power sources—an *A-side* power source and a *B-side* power source—that provide power to the system's power receptacles. Either source must be capable of continuing to provide power if power to the other source is lost.

The A-side power source provides power to the top power-supply unit (PSU) in the system. The B-side power source provides power to the bottom PSU.

Each PSU in the system is capable of providing power to the entire system. When both PSUs have electrical power, they share the load of the system components; however, if one PSU fails or if power is lost to either the A- or B-side power source, the remaining PSU can pick up the full load of the system.

Although either PSU is capable of powering the ztC Endurance system, it is still important to separate power sources as much as possible to maximize redundancy. Furthermore, if you connect user-supplied peripheral components that also contain two PSUs, attach each side to the independent A- and B-side power sources. For components that do not require two sources of power, such as monitors, management PCs, or other user-supplied components, you typically attach these components to the A-side power source.

If provided by the customer, a pair of PDUs may supply power to multiple systems and components in a cabinet. The top PDU in the cabinet typically provides A-side power. The bottom PDU typically provides B-side power.

AC Power and HVAC Service Requirements

Use the specifications in the "AC Power" section of ["System Specifications" on page 293](#) to determine AC power and HVAC requirements for the ztC Endurance system. Because the ztC Endurance PSUs balance the load of the system components, the total power requirement for either side of the system should not exceed the system specifications listed in the "AC Power" section.

For any optional components, see the included documentation to obtain the nominal input line voltage (volts AC) and frequency (Hz) required.



Notice: A branch circuit breaker with ground fault protection must allow a minimum of 3.5 milliamperes (mA) leakage current for each power cord.

See ["System Specifications" on page 293](#) for additional ztC Endurance system specifications.

Electrical Power Connections

Provide two AC power sources that are as electrically independent of each other as the installation site allows. At a minimum, the two power sources must be powered by separate circuit breakers (maximum of 20A) to AC power and, if possible, be independent of each other beyond that level. The more electrical separation between the two power sources, the less likely they will both fail at the same time. Due to redundancy in ztC Endurance systems, power to either side of the system keeps the system in operation.

Figure 2-1 shows an example of how to connect a ztC Endurance system directly to two separate AC power sources.

Figure 2-1: Connecting a System Directly to AC Power

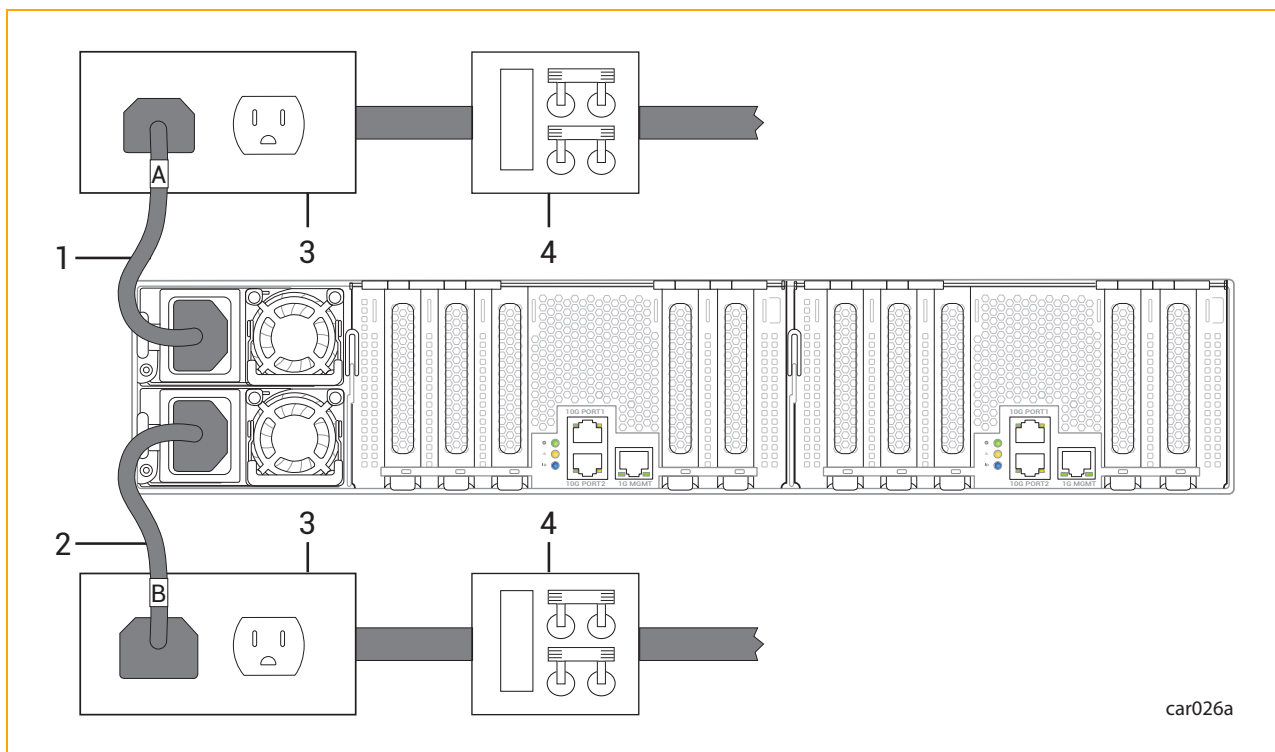

1	A-side power cord	3	AC power outlets
2	B-side power cord	4	AC power (mains) distribution circuit breakers (maximum of 20A)

Related Topics

- ["PSUs" on page 35](#)
- ["Removing and Replacing a PSU and Power Cords" on page 130](#)
- ["Power Cords" on page 43](#)
- [Connecting the System to Electrical Power](#)

Power Cords

Penguin Solutions supplies tested and approved AC power cords for the ztC Endurance system and for Penguin Solutions-supplied peripheral components.



Caution: Place all power cords out of the way of foot traffic.



Précaution: Éloigner tous les cordons d'alimentation du passage.

Power cords described as "Domestic" are made with American Wire Gauge (AWG) cordage and are intended for use in North America. Refer to UL 62 and CSA C22.2, No. 49. All other power cords are made with international cordage and are intended for use in the specified countries, and in other countries that use that standard.

[Table 2-1](#) lists the available power cords that connect ztC Endurance systems directly to an AC power source (not to a PDU or to a UPS).

Table 2-1: Power Cords: ztC Endurance Systems to AC Power

Marketing ID	Plug Type	Rating	Length	Locale
ZEN-PWR-211	IEC 60320 C19 to CEE 7 VII	16A/250V	8.2 ft (2.5m)	Europe, Korea
ZEN-PWR-212	IEC 60320 C19 to IEC/EN 60309	16A/250V	8.2 ft (2.5m)	United King- dom, Singa- pore
ZEN-PWR-213	IEC 60320 C19 to SAA/3/15	15A/250V	8.2 ft (2.5m)	Australia
ZEN-PWR-214	IEC 60320 C19 to IND/3/16 IS694	16A/250V	8.2 ft (2.5m)	India
ZEN-PWR-215	IEC 60320 C19 to JIS C8303	15A/250V	8.2 ft	Japan

	6/15AJ		(2.5m)	
ZEN-PWR-216	IEC 60320 C19 to GB2099/GB1002	16A/250V	8.2 ft (2.5m)	China
ZEN-PWR-217	IEC 60320 C19 to NBR14136	16A/250V	8.2 ft (2.5m)	Brazil
ZEN-PWR-218	IEC 60320 C19 to CNS 690	15A/250V	8.2 ft (2.5m)	Taiwan
ZEN-PWR-221	IEC 60320 C19 to NEMA 6-20	20A/250V	8.2 ft (2.5m)	United States
ZEN-PWR-225	IEC 60320 C19 to ZA/3 SABS 164-1	16A/250V	8.2 ft (2.5m)	South Africa
ZEN-PWR-226	IEC 60320 C19 to NEMA L6-20	20A/250V	8.2 ft (2.5m)	Japan
ZEN-PWR-220 (low voltage) ¹	IEC 60320 C19 to 498GJTW	15A/125V	8.2 ft (2.5m)	Japan and Taiwan
ZEN-PWR-222 (low voltage) ¹	IEC 60320 C19 to NEMA 5-20	20A/125V	8.2 ft (2.5m)	United States



Note: When ordering individual power cords as spares or upgrades, the product's Marketing ID should be followed by -P.

Related Topics

- ["PSUs" on page 35](#)
- ["Removing and Replacing a PSU and Power Cords" on page 130](#)
- [Connecting the System to Electrical Power](#)
- ["Electrical Power Connections" on page 42](#)

¹Not supported for low-voltage ztC Endurance 5110 systems that contain 512 GB of memory.

Grounding Requirements



Warning: Incorrect grounding can cause severe personal injury and extensive equipment damage.



Avertissement: Une mise à la terre incorrecte peut provoquer des blessures graves et endommager sérieusement l'équipement.

The ztC Endurance system obtains its protective earth (PE) ground through the power cord. See ["Grounding Considerations" on page 135](#) for a more complete discussion of ztC Endurance system grounding.

Space Planning

For information about planning sufficient space for a ztC Endurance system, see:

- ["Room Requirements" on page 45](#)
- ["Planning for Cables" on page 46](#)

Room Requirements

To ensure that the installation site provides a properly equipped, cooled, and sized environment, make sure that the site:

- Provides clearances for air circulation, opening cabinet doors, removing cabinet panels, and servicing the system from the front and rear.

Locate the front and rear of the system at least 2.5 feet (ft) (0.76 meters (m)) away from walls and other obstructions.

- Maintains reasonable temperature and humidity levels, and has a thermometer and humidistat to monitor room temperature and humidity.

See ["AC Power and HVAC Service Requirements" on page 41](#) for detailed information about HVAC planning and ["System Specifications" on page 293](#) for detailed information about temperature and humidity requirements.

- Is as free as possible of airborne contamination (particulate and gaseous).



Notice: Due to the mission-critical nature of ztC Endurance servers, data centers housing the equipment should follow the guidelines of airborne contamination (particulate and gaseous) as outlined in the ASHRAE (TC) 9.9 documentation. Particulate matter to adhere to ISO 14644-1 Class 8. Gaseous contamination, such as sulfur or chlorine-bearing gases to adhere to ANSI/ISA-71.04-1985 Severity level G1.

Dust buildup in the system can impede air circulation and heat transfer, causing components to become less reliable as the ambient temperature rises.

Fans clogged by dust fail to expel hot air, causing circuit boards to overheat and fail.

Dust on circuit boards raises the temperature, thus reducing the component's mean time between failure (MTBF).

Dust circulating in the room increases the risk of fire within the room by providing potential combustible material within the environment.

Dust contamination on tape devices causes mis-reads and -writes, leading to failure of attempts to back up and restore data.

- Provides two electrically separate grounded AC wall outlets, within reach of the power cords from the system or PDUs, and, if used, UPS units. If the power cord must be hardwired, consult an electrician to plan the length of the power cord.
- Provides cutouts in the floor for routing cables, if the site has an elevated floor.
- Contains space for future expansion.



Caution: Do not place the system in an area of high electrostatic discharge. Static electricity may damage components. Do not locate components near transformers or other electromagnetic devices.



Précaution: Ne pas placer le système dans une zone de forte décharge électrostatique. L'électricité statique peut endommager les composants. Ne pas placer de composants à proximité de transformateurs ou d'autres appareils électromagnétiques.

See "[System Specifications](#)" on page 293 for the dimensions of system components.

Planning for Cables

To accommodate cables from the system, make sure to provide:

- Ethernet jacks, switches, or hubs, as needed
- Two electrically separate grounded AC wall outlets, or a UPS and a wall outlet, within reach of the power cords from the system or PDUs, and additional outlets for any components that do not connect to a PDU
- AC wall outlets within reach of the power cords from optional components such as monitors, management PCs, or other users-supplied components; or use PDUs

Make sure that cables you plan to connect to the system are long enough to reach between the system and external components or connections. For information about specific cables and power cords, see the following topics:

- "Power Cords" on page 43
- "Communications Line Planning" on page 47
- "Site Planning for Peripheral Components" on page 50

Communications Line Planning

Make sure that you plan the locations of the ztC Endurance system and its external components so that all communications and data cables will reach their connection points.

Notes:



1. If you have a unique network requirement, call Penguin Solutions Customer Service at the phone number listed on the **Penguin Solutions Customer Service** page at <https://www.penguinsolutions.com/en-us/support>.
2. See "System Specifications" on page 293 for the PCIe adapters that Penguin Solutions supplies for the ztC Endurance system.

Related Topics

- "PCIe Adapters" on page 31

Cabinet Requirements

In general, consider the following factors during your site planning for systems in cabinets:

- Elevated Operating Ambient Temperature—If installed in a closed or multi-unit rack assembly, the operating ambient temperature of the rack environment may be greater than room ambient. Therefore, consideration should be given to installing the equipment in an environment compatible with the maximum ambient temperature (T_{ma}) specified by the manufacturer.

- **Reduced Air Flow**—Installation of the equipment in a rack should be such that the amount of air flow required for safe operation of the equipment is not compromised.
- **Mechanical Loading**—Mounting of the equipment in the rack should be such that a hazardous condition is not achieved due to uneven mechanical loading.
- **Circuit Overloading**—Consideration should be given to the connection of the equipment to the supply circuit and the effect that overloading of the circuits might have on overcurrent protection and supply wiring. Appropriate consideration of equipment nameplate ratings should be used when addressing this concern.
- **Reliable Earthing**—Reliable earthing of rack-mounted equipment should be maintained. Particular attention should be given to supply connections other than direct connections to the branch circuit (for example, use of power strips).

Make sure that the cabinet meets the following requirements:

- The cabinet can support the weight of all of the components you plan to install in it. "[System Specifications](#)" on page 293 provides the weights of ztC Endurance system components. To determine the weight of any peripheral components, see the documentation included with those components.
- The cabinet contains two front and two rear vertical EIA rails, one in each corner of the cabinet, that have the universal hole pattern as defined in the EIA 310-D Section 1 specification.
- The front vertical rails extend at least 0.5 in. (1.27 centimeters (cm)) beyond the inside edge of the accessory leg, if present, to allow the mounting rails to be fitted.
- The distance between the front vertical rails and the inside of the front door is at least 3.0 in. (7.62 cm).
- The distance between the rear of the system chassis and the inside of the rear door is at least 6.0 in. (15.24 cm).
- The distance between the front and rear vertical rails is between 24 in. and 31.5 in. (60.96 cm and 80 cm, respectively).
- The vertical mounting rails have a 0.275 in. (7.0 mm) round or 0.375 in. (9.53 mm) square pattern, with a thickness between 0.063 in. - 0.105 in.
- The vertical mounting rails are plated, or some other method is used to ensure continuity for grounding between installed equipment.
- Cable-management brackets are provided to support and constrain data and power cords so that the cables do not interfere with air flow out of the rear of the modules, and so that the connectors do not disconnect or break.

- To prevent stray voltages, all components are grounded together through the vertical mounting rails to the cabinet frame, and then to local building ground. To ensure signal quality, use a grounding cable for local building ground.
- There is a plan for maintaining cables and wires to the cabinet by either running them under the floor or placing them overhead in an overhead cable tray.
- Air flows through the cabinet from front to back.
- Air does not recirculate within the cabinet.
- Filler panels cover any unused rack space to prevent air recirculation.
- Blockers are installed between the vertical mounting rails and the side panels at the rear of the cabinet.
- Vents are evenly distributed on the front and rear doors and make up at least 69% of the surface area.



Caution: The cabinet must have vented front and rear doors to prevent the system from overheating while in operation.



Précaution: L'armoire doit avoir des portes avant et arrière ventilées pour empêcher le système de surchauffer pendant le fonctionnement.

- The final installation conforms to all emission, immunity, safety, and other applicable regulations.



Notice: A ztC Endurance system allows you to install USB cables and USB flash drives in the front of the system, as well as various data and power cables in the rear of the system. The recommended clearance dimensions of 76 mm from front rails to the door, and 152 mm between the rear of the system chassis and the inside of the rear door, ensure that there are no clearance issues with the previously mentioned accessories or device. Although not recommended, a 1000 mm rack may be possible if the cabinet rails are skewed to the front, thus preventing use of accessories in the front of the system, while allowing more space for cabling in the rear.

Examples of recommended cabinets for system installation follow:

- With a vertical PDU installed, xU high x 31.5 in. (800 mm) wide x 47.2 in. (1200 mm) deep. For example: APC™ NetShelter™ SV AR2580-42U

- Without a PDU installed, xU high x 23.6 in. (600 mm) wide x 42.1 in. (1070 mm) deep. For example: APC NetShelter SX AR3104-24U

Site Planning for Peripheral Components

Remember to plan for any additional peripheral components, which can include a keyboard, mouse, and monitor, as well as other devices.

To install VMware ESXi, you need to connect a keyboard and monitor to compute module B, as described in ["II. Connect a Mouse, Keyboard, and Monitor" on page 74](#). After installation, you can optionally disconnect the monitor and keyboard for headless operation and manage the system remotely, as described in ["Configuring System Management Options" on page 188](#).

If you need to continue managing the system from the local console on a regular basis, consider connecting the VGA and USB ports of both compute modules to a KVM switch, and, as needed, switch KVM ports to view the console of the active compute module.

For your monitor, ensure that:

- The monitor accepts universal 100-240 volts AC (VAC), 50/60 Hertz (Hz) power.
- The VGA cable has a 15-pin D-sub connector if you are connecting it directly to a compute module.
- The power cord for the monitor is long enough to reach the power source.
- The plug type on the power cord is compatible with the external power source at the site.

ztC Endurance systems support the ZEN-PERIPH-KBMS keyboard and mouse. See ["System Specifications" on page 293](#) for the specifications for this keyboard and mouse.

A 6-ft (1.83-m) USB cable is attached to the keyboard. Another 6-ft (1.83-m) USB cable is attached to the mouse.

3

Chapter 3: Installing and Connecting the ztC Endurance System Hardware

When you receive your ztC Endurance system, unpack it as shown on the flap of your system shipping box. You can then review [ztC Endurance 3xx0, 5xx0, and 7xx0 Systems: Deploying a System](#) (R002C), which is located in the shipping box, for a brief overview of your system.



Notice: Make sure you read and understand the important safety information in "Safety Precautions" on page 51 before you begin installing and connecting the system.

Next Steps

Begin installing the ztC Endurance system as described in "Installing the System in a Cabinet" on page 62.

Safety Precautions

Before installing the system, take the following important precautions:

- Observe all applicable industry safety standards. See "Safety Notices" on page 52.
- Provide the necessary space and light to safely perform the installation.
- Do not wear conducting objects, such as rings, bracelets, and keys.

See "Warnings, Cautions, Notices, and Notes" on page 52 for information about the types of cautionary notes used in this document.

Warnings, Cautions, Notices, and Notes

Warnings, cautions, notices, and notes provide special information and have the following meanings:



Warning: A warning indicates a hazardous situation that, if not avoided, could result in death or serious injury.



Avertissement: Un avertissement indique une situation dangereuse qui, si pas évitée, pourrait entraîner la mort ou des blessures graves.



Caution: A caution indicates a hazardous situation that, if not avoided, could result in minor or moderate injury.



Précaution: Une mise en garde indique une situation dangereuse qui, si pas évitée, pourrait entraîner des blessures mineures ou modérées.



Notice: A notice indicates information that, if not acted on, could result in damage to a system, hardware device, program, or data, but does not present a health or safety hazard.



Note: A note provides important information about the operation of a ztC Endurance system or related equipment or software.

Safety Notices

In addition to the safety notices described here, also see:

- ["Environmental Warnings" on page 57](#)
- ["Safety Precautions When Setting Up and Shipping Equipment" on page 58](#)
- ["Power Cord Warnings and Cautions" on page 58](#)
- ["Electrostatic Discharge \(ESD\) Warnings" on page 61](#)
- ["Rack System Installation" on page 62](#)



Caution: Risk of explosion if battery is replaced by an incorrect type. Dispose of used batteries according to the instructions provided with the battery.



Précaution: Il y'a risque d'explosion si la batterie est remplacée per une batterie de type incorrect. Mettre au rebut les batteries usagées conformément aux instructions.



Warning: The system uses two power cords to provide redundant sources of power. To fully remove power from a system, disconnect both power cords.



Avertissement: Le système utilise deux cordons d'alimentation pour fournir des sources d'alimentation redondantes. Pour que le système ne soit plus alimenté, déconnecter les deux cordons d'alimentation.



Caution: To prevent a cabinet from tipping over and injuring a person or damaging the system, start installing systems from the bottom of the cabinet upward.



Précaution: Pour empêcher une armoire de basculer et blesser une personne ou endommager le système, installer le système sur la partie inférieure de l'armoire vers le haut.



Warning: To avoid fire, electric shock, and equipment breakdown, prevent water or foreign objects from getting into the equipment. Do not let water or foreign objects, such as pins or paper clips, enter the equipment.



Avertissement: Afin d'empêcher un incendie, un choc électrique et la panne de l'équipement, empêcher l'eau ou les objets étrangers de pénétrer dans l'équipement. Ne pas laisser l'eau ou les objets étrangers, comme des épingles ou des trombones, entrer dans l'équipement.



Warning: To prevent fire or current leakage, do not plug the power cord into a nonconforming outlet. Use a power outlet with appropriate voltage and power type, as specified in this guide.



Avertissement: Pour empêcher un incendie ou une fuite de courant, ne pas brancher le cordon d'alimentation dans une prise non conforme. Utiliser une prise de courant avec la tension et le type d'alimentation appropriés, comme indiqué dans ce guide.



Caution: Do not install the equipment where you may need an extension cord. Use of an extension cord that does not meet the power specifications introduces a risk of overheating that could lead to a fire.



Précaution: Ne pas installer l'équipement là où il est nécessaire d'utiliser une rallonge. L'utilisation d'une rallonge non conforme aux spécifications en matière d'alimentation induit un risque de surchauffe, ce qui pourrait causer un incendie.



Warning: Disconnect the power cords from the server or power source before you install or relocate the equipment. All voltage is removed only when the power cords are disconnected.



Avertissement: Débrancher les cordons d'alimentation du serveur ou de la source d'alimentation avant d'installer ou de déplacer l'équipement. La tension est éliminée uniquement lorsque les cordons d'alimentation sont débranchés.



Warning: To reduce the risk that electrical shock could injure a person or damage the system, exercise caution when working in the unit even when only one power cord is connected.



Avertissement: Pour réduire le risque qu'un choc électrique puisse blesser une personne ou endommager le système, soyez prudent lorsque vous travaillez dans l'appareil, même lorsqu'un seul cordon d'alimentation est connecté.



Warning: Do not disassemble, repair, or alter the server, except as described in this documentation. There are no user-serviceable parts within the chassis. The modules and PSU are all tool-less serviceable. Do not use any tools to access or remove any panels or covers. There is a risk of an electric shock or fire as well as equipment malfunction if you do not observe the instructions in this documentation.



Avertissement: Ne pas démonter, réparer, ou altérer le serveur, excepté tel que décrit dans cette documentation. Il n'y a pas de pièces pouvant être réparées par l'utilisateur dans le châssis. Les modules et le bloc d'alimentation peuvent être réparés entièrement sans outil. Ne pas utiliser d'outils pour retirer ou accéder aux panneaux ou aux couvercles. Il y a un risque de choc électrique ou d'incendie, ainsi que de mauvais fonctionnements de l'équipement, si vous ne respectez pas les instructions dans cette documentation.



Caution: Do not place any object on top of the server. The object may fall off and cause injuries, damage to hardware, or a fire.



Précaution: Ne pas placer d'objet en haut du serveur. L'objet peut chuter et causer des blessures, endommager le matériel, ou causer un incendie.



Caution: To reduce the risk of personal injury from hot surfaces, allow the drives and the internal system components to cool before touching them.



Précaution: Pour diminuer le risque de blessure au contact de surfaces chaudes, laissez refroidir les lecteurs et les composants internes du système avant de les toucher.



Warnings:

To reduce the risk of personal injury or damage to the equipment:

1. Observe local occupational health and safety requirements and guidelines for manual material handling.
2. Get help to lift and stabilize the product during installation or removal, especially when the product is not fastened to the rails. This server weighs between 74-102 lb (33.6-46.3 kg).

Avertissements:

Pour diminuer le risque de blessure ou de dommage à l'équipement:



1. Respectez les exigences et les directives en matière de santé et de sécurité au travail pour la manutention manuelle du matériel.
2. Faites-vous aider pour lever et stabiliser le produit pendant l'installation ou le retrait, en particulier quand le produit n'est pas fixé aux rails. Le serveur pèse entre 33,6 et 46,3 kg (74 à 102 lb). Ce poids indique qu'il faut au minimum trois personnes pour lever le système pendant le déballage, le déplacement et l'installation du système dans un bâti.



Caution: Observe caution when inserting compute, storage, or I/O modules. These are moving parts. Keep fingers clear to avoid any possible pinching when pushing the modules into a latched position.



Précaution: Soyez prudent lorsque vous insérez une unité centrale de traitement, de la mémoire ou des modules E/S. Ces pièces sont mobiles. Garder les doigts à l'écart pour éviter un pincement au moment de verrouiller les modules en place.



Notice: Do not install or store the equipment in an unsuitable place. Install or store the equipment in a place that meets the requirements specified in this guide.

Environmental Warnings

Cautions:



1. Do not use or store this product in a corrosive environment.
2. Avoid using or storing this product in an environment that may contain corrosive gases. Such gases include, but are not limited to, sulfur dioxide, hydrogen sulfide, nitrogen dioxide, chlorine, ammonia, or ozone.
3. Avoid installing this product in a dusty environment or one that may contain corrosive materials such as sodium chloride or sulfur.
4. Avoid installing this product in an environment having excessive metal flakes or conductive particles in the air. Such environments may cause corrosion or short circuits within this product, resulting in not only damage to this product, but also fire.
5. If there are any concerns regarding the environment at the planned site of installation or storage, contact your authorized Penguin Solutions service representative.

Précautions:



1. Ne pas utiliser ou entreposer ce produit dans un milieu corrosif.
2. Éviter d'utiliser ou d'entreposer ce produit dans un environnement qui peut contenir des gaz corrosifs. Ces gaz incluent, mais sans s'y limiter, le dioxyde de soufre, le sulfure d'hydrogène, le dioxyde d'azote, le chlore, l'ammoniac ou l'ozone.
3. Éviter d'installer ce produit dans un environnement poussiéreux ou dans un environnement qui contient des matières corrosives comme le chlorure de sodium ou le soufre.
4. Éviter d'installer ce produit dans un environnement qui contient des écailles de métal ou des particules conductrices dans l'air. Ce type d'environnement peut causer de la corrosion ou des courts-circuits dans le produit, ce qui endommagerait le produit, mais causerait également un incendie.
5. Si vous avez des inquiétudes concernant l'environnement du site où il est prévu d'installer ou entreposer le produit, contactez votre représentant de service Penguin Solutions autorisé.

Safety Precautions When Setting Up and Shipping Equipment

For your protection, observe the following safety precautions when setting up and shipping your equipment:

- Follow all cautions and instructions marked on the equipment.
- Ensure that the voltage and frequency of your power source match the voltage and frequency written on the equipment's electrical rating label.
- Never push objects of any kind through openings in the equipment. Dangerous voltages, energy, or moving parts may be present. Conductive external objects could produce a short circuit that could cause fire, electric shock, or damage to your equipment.
- Do not block or cover the openings of your product. Never place a product near a radiator or heat register. Failure to follow these guidelines can cause overheating and affect the reliability of your product.
- Do not drop the product or subject it to physical shock.
- Keep the product away from water or any liquid.
- To ship the product, pack it inside the qualified package and ship with a pallet.

Power Cord Warnings and Cautions

Installation of this equipment must comply with local and regional electrical regulations governing the installation of information technology equipment by licensed electricians. For electrical power ratings on options, refer to the power rating label or the user documentation supplied with that option.

Warnings:



1. When installing a system, always connect the power cord first, before adding communications cables.
2. The power cord contains the protective earth connection; it should be connected first and disconnected last, to maintain a grounded chassis.
3. Before attempting to remove a module from the system chassis, power off the module, disconnect communications cables, and then disconnect the power cord. Before attempting to remove a PSU, disconnect the power cord.
4. Never connect a power cord to a module or PSU when it is not located within the system chassis.
5. Do not connect communications cables to an I/O module that is not installed in a grounded system chassis. Disconnect all communications cables to the I/O module before removing the I/O module from the chassis.

Avertissements:



1. Lors de l'installation du système, toujours connecter le cordon d'alimentation en premier, avant d'ajouter les câbles de communication.
2. Le cordon d'alimentation inclut le raccordement à la terre, il doit être connecté en premier et déconnecté en dernier afin que le châssis reste relié à la terre.
3. Avant d'essayer de supprimer un module du châssis du système, s'assurer que le module est hors tension et les câbles de communication sont débranchés. Avant d'essayer de retirer un bloc d'alimentation, débrancher le cordon d'alimentation.
4. Ne jamais connecter un cordon d'alimentation à un module ou un bloc d'alimentation quand il n'est pas situé dans le châssis du système.
5. Ne pas connecter les câbles de communication à un module E/S qui n'est pas installé dans le châssis d'un système relié à la terre. Débrancher tous les câbles de communication du module E/S avant de retirer le module E/S du châssis.

Cautions:



1. This product is designed to work with multiple types of grounding systems, specifically TN, where neutral is grounded and for both IT and TN-C where grounded neutral is not used. For IT and TN-C, the branch circuit for L1 and L2 must be supplied by a double-pole circuit breaker. Contact your facilities manager or a qualified electrician if you are not sure what type of power is being supplied to the system.
2. Not all power cords have the same current ratings. Do not use the power cord provided with your equipment for any other products or use. Do not use household extension cords with your product.
3. The outlet for the DC power supply should not be far away from the equipment when using.

Précautions:



1. Ce produit est conçu pour fonctionner avec plusieurs types de systèmes de mise à la terre, en particulier TN, où le neutre est mis à la terre, et avec les systèmes IT et TN-C où le neutre relié à la terre n'est pas utilisé. Pour les systèmes IT et TN-C, le circuit de dérivation pour L1 et L2 doit être fourni par un disjoncteur à deux pôles. Contactez votre responsable de réseau ou un électricien qualifié si vous n'êtes pas sûr de savoir quel type d'alimentation est fournie au système.
2. Tous les cordons d'alimentation n'ont pas les mêmes courants nominaux. Utiliser uniquement le cordon d'alimentation fourni avec votre équipement. Ne pas utiliser des cordons d'alimentation domestiques avec votre produit. Ne pas utiliser le cordon d'alimentation fourni avec votre équipement avec d'autres produits ou pour une autre utilisation.
3. La prise d'alimentation C.A. ne doit pas être éloignée de l'équipement pendant son utilisation.

Electrostatic Discharge (ESD) Warnings

Cautions:



1. In order to maximize overall product quality and eliminate the possibility of damage from electrostatic discharge, observe ESD handling procedures wherever this symbol occurs during the system integration.
2. All employees must attend an ESD training class prior to performing any system or board handling. If you have not been properly trained, contact your immediate supervisor to schedule the training.
3. Use heel straps on both feet and/or wrist straps where applicable to ensure that you are properly grounded. Test the continuity of the straps at a certified ESD station before working with the products.
4. If you remove your heel straps or wrist straps for any reason, you must retest to ensure proper grounding.
5. Ensure the policies regarding ESD controls for all personnel who work in the manufacturing departments are enforced.

Précautions:



1. Afin de maximiser la qualité générale du produit et d'éliminer la possibilité de dommage dû à une décharge électrostatique, respectez les procédés de manutention ESD quand le symbole suivant apparaît pendant l'intégration du système.
2. Tous les employés doivent suivre un cours de formation ESD avant d'effectuer la manutention du système ou du tableau. Si vous n'avez pas été correctement formé, contactez votre superviseur immédiat pour planifier la formation.
3. Des bandes antistatiques pour talon à chaque pied et/ou des bracelets antistatiques, le cas échéant, doivent être utilisés pour garantir que vous êtes correctement mis à la terre pendant le test de continuité des bandes au poste ESD certifié.
4. Si vous retirez vos bandes antistatiques pour talon ou vos bracelets antistatiques pour une raison particulière, vous devez refaire le test pour garantir la mise à la terre correcte.
5. Assurez-vous que les politiques concernant les contrôles ESD sont appliquées pour tout le personnel qui travaille dans les départements de production.

Rack System Installation

The installation instructions include rack-mount instructions identical to or similar to the ones listed in ["Cabinet Requirements" on page 47](#). Be sure to carefully read and observe the Cautions listed in that topic.

Related Topics

- ["General Safety Precautions" on page 105](#)

Installing the System in a Cabinet

The general steps for installing the ztC Endurance system in a cabinet are as follows:

1. Number the vertical rails
2. Prepare the support rails for installation
3. Attach the support rails and insert the system into the cabinet

However, before installing the system in a cabinet, make sure that:

- You read and understand all safety precautions in ["Safety Precautions" on page 51](#).
- You read and understand all of the installation steps.
- Your cabinet meets the system requirements, and the site has been properly prepared (see ["Cabinet Requirements" on page 47](#)).
- You write down the asset ID, which is located on top of the system chassis (see [Figure 3-1](#)), and store it in a convenient location.



Caution: Making note of the asset ID now is critical. After you install the system, the asset ID label may not be visible in the cabinet, and you need to provide the asset ID during the software installation.

Figure 3-1: Location of Asset ID

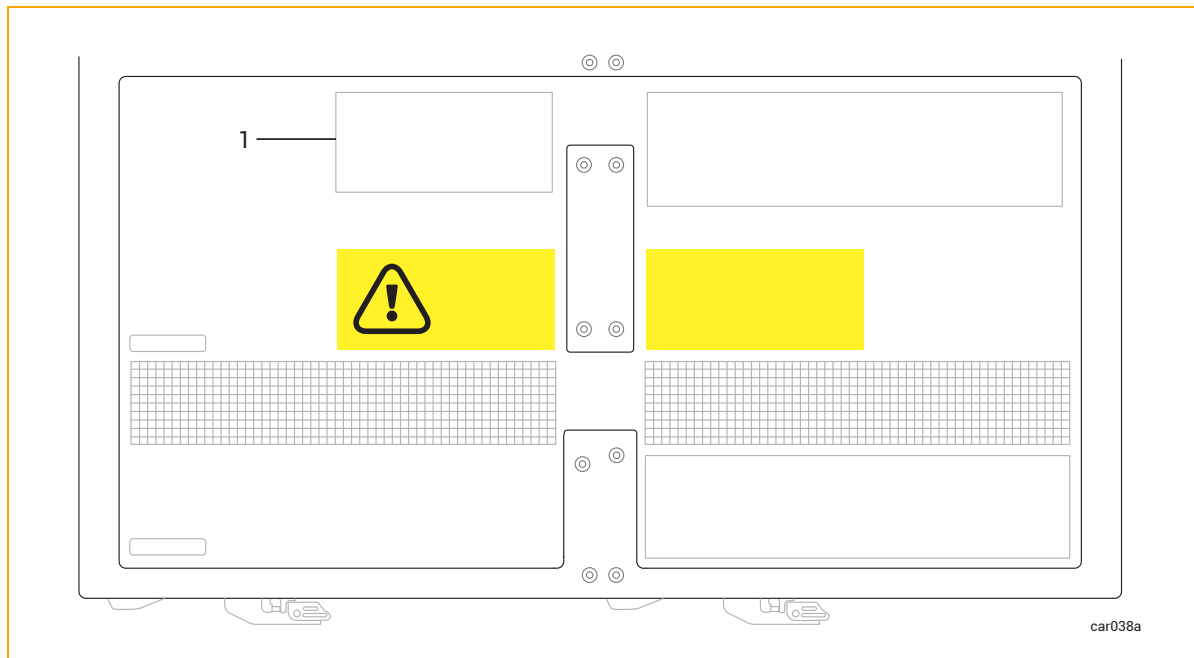

1 Label with asset ID

- You have the components to install:
 - Support rails (2). One is labeled **FRONT LEFT**, and the other is labeled **FRONT RIGHT**. The rails can be extended from 26 3/8 in. (670 mm) to 34 1/4 in. (870 mm).
 - Package labeled **R0897-E0112-01** that contains eight flat-head alignment screws (silver). Use these screws to align the mounting rails to the cabinet during installation.
 - Package labeled **R0897-E0113-01** that contains four Phillips/hex-head screws (black). Use these screws to secure the rail to the rear of the cabinet.
- You have the required tools: a flat-head screwdriver and a #2 Phillips-head screwdriver.



Caution: To avoid personal injury or damage to the system, two persons are recommended to insert the system in a cabinet.



Précaution: Pour éviter toute blessure corporelle ou tout dommage à l'étagère, deux personnes sont recommandées pour insérer l'étagère dans l'armoire et sur les supports de montage.

Next Steps

Start installing the system in a cabinet as described in ["Numbering the Vertical Rails" on page 64](#).

Numbering the Vertical Rails

When you install a system in a cabinet, you first need to number the vertical rails, if they are not already numbered. To do so, use a marker or pencil to number the holes of the 2U in which to install each system.

The cabinet rails, system, and various components are measured in Electronic Industries Alliance (EIA) rack units (U). Every three holes on the EIA square-hole pattern on the vertical rail equals one U (1.75 in., 4.45 cm). The holes on EIA rails are in a repeating pattern of 1/2 in. (1.27 cm), 5/8 in. (1.59 cm), 5/8 in. (1.59 cm), as shown in [Figure 3-2](#). The middle hole of each U has equal spacing between it and the holes adjacent to it. In some cabinets, numbers on the vertical rails identify the middle hole of each U.

Figure 3-2: EIA Vertical Rail Hole Pattern

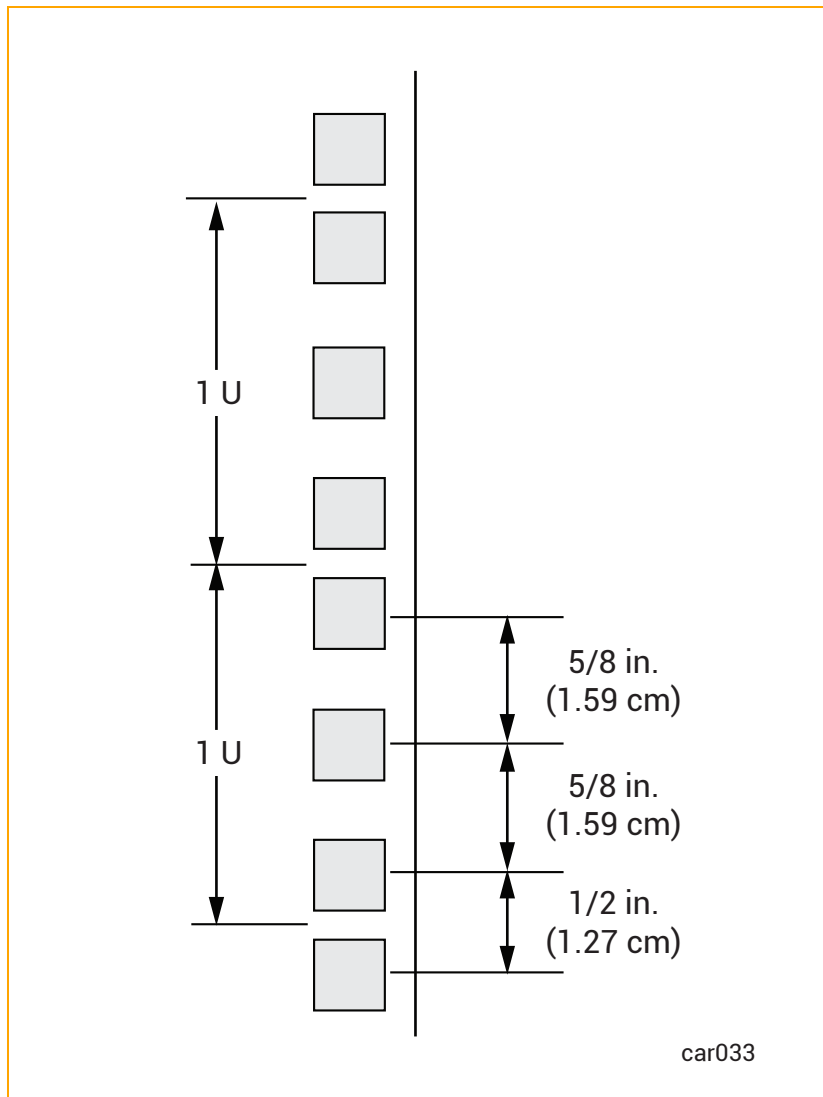

To number the vertical rails

1. On each of the front and rear vertical rails, number the 2U spaces where you will install the system.



Notice: To ensure that the components will be level when you install them, mark the same holes on the rear vertical rails that you marked on the front vertical rails.

2. If you are installing additional systems in the same cabinet, continue numbering another 2U for each system.

Next Steps

To continue with installing a system in a cabinet, see ["Preparing the Support Rails for Installation" on page 66](#).

Preparing the Support Rails for Installation

When installing a system in a cabinet, you need to prepare the support rails for installation after you have numbered the vertical rails.

To prepare the support rails

1. Unpack the components and place them on a stable work surface. Attached to the rails are alignment/support screws for use in cabinet rails with round 13/64 in. (5 mm) holes.
 - If your cabinet rails have round 13/64 in. (5 mm) mounting holes, skip this section and continue to ["Attaching the Support Rails and Inserting the System" on page 69](#).
 - If your cabinet rails have square 3/8 in. (9.525 mm) mounting holes, use the silver alignment screws (located in the package labeled **R0897-E0112-01**) in place of the screws that are already installed. Go to step 2.
2. Positioning a flat-head screwdriver in the middle of the front latch, pry open the latch. See [Figure 3-3](#).

Figure 3-3: Positioning Screwdriver and Opening Latch

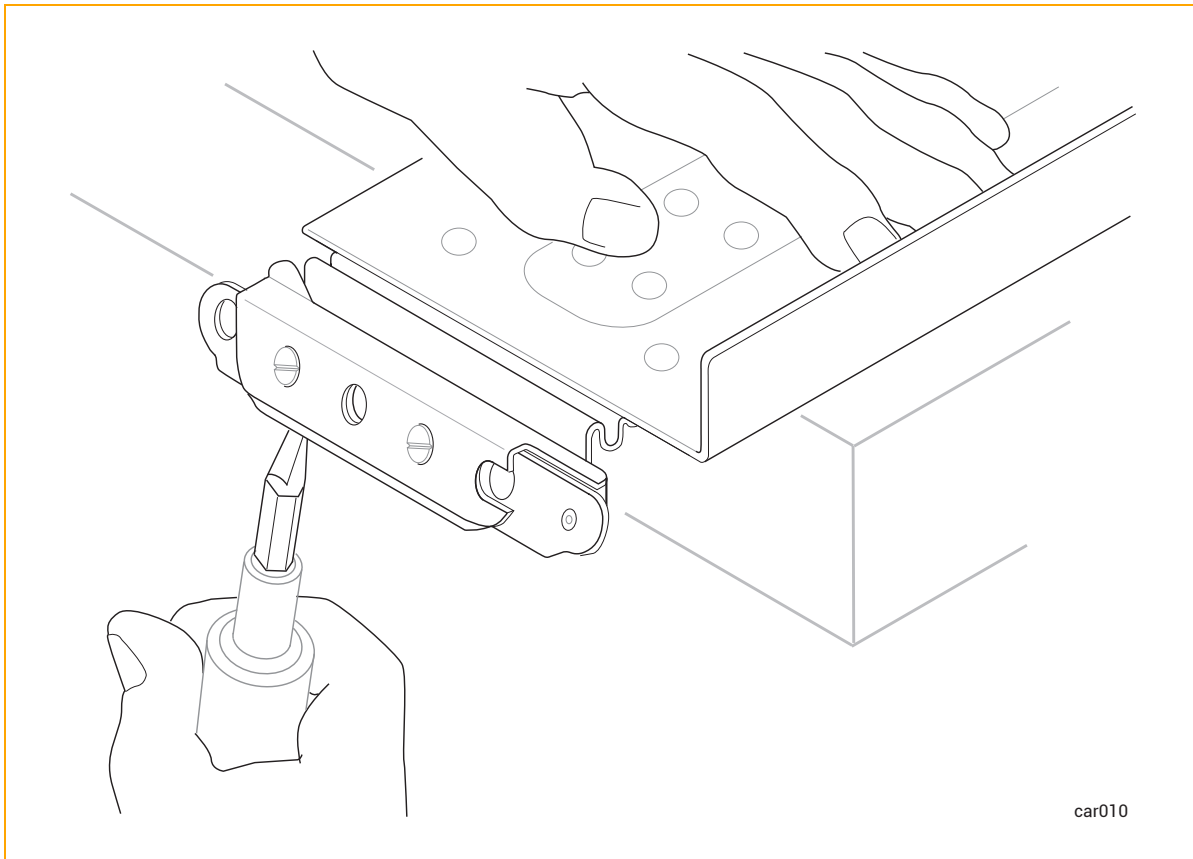

3. While the latch is in the open position, use a flat-head screwdriver to remove the two existing alignment screws. See [Figure 3-4](#).

Figure 3-4: Removing Existing Alignment Screws

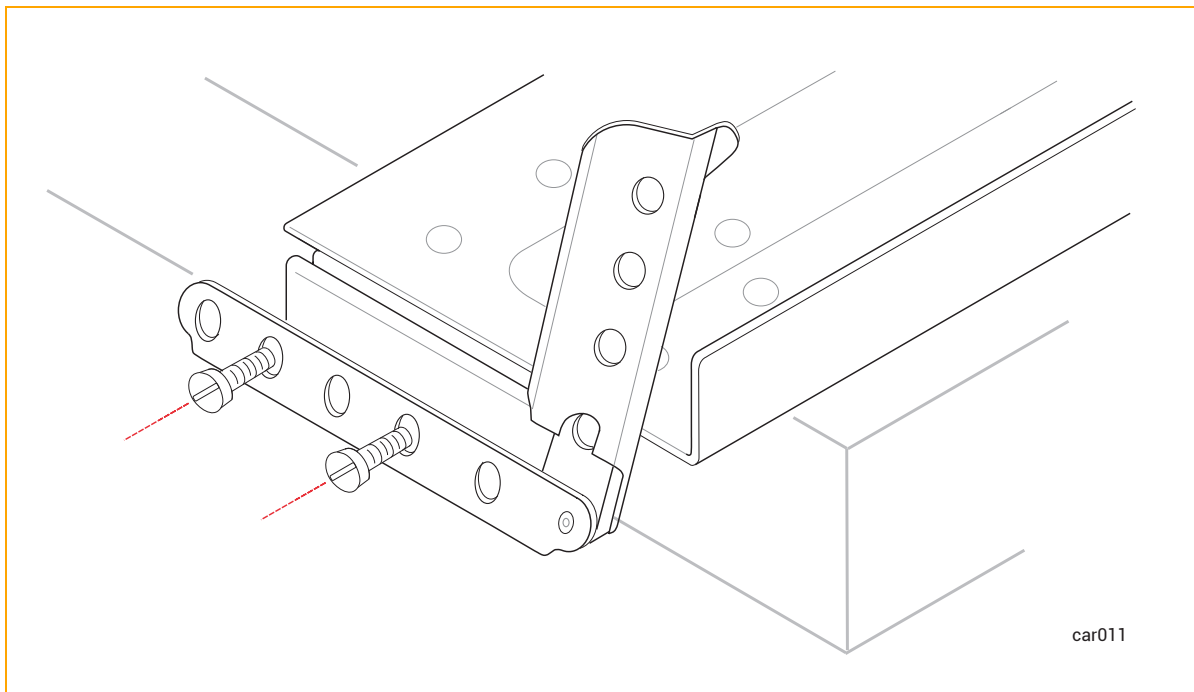

4. Use a flat-head screwdriver to attach two silver alignment screws in the holes that the previous alignment screws were in. Keep the latch open. See [Figure 3-5](#).

Figure 3-5: Attaching Silver Alignment Screws

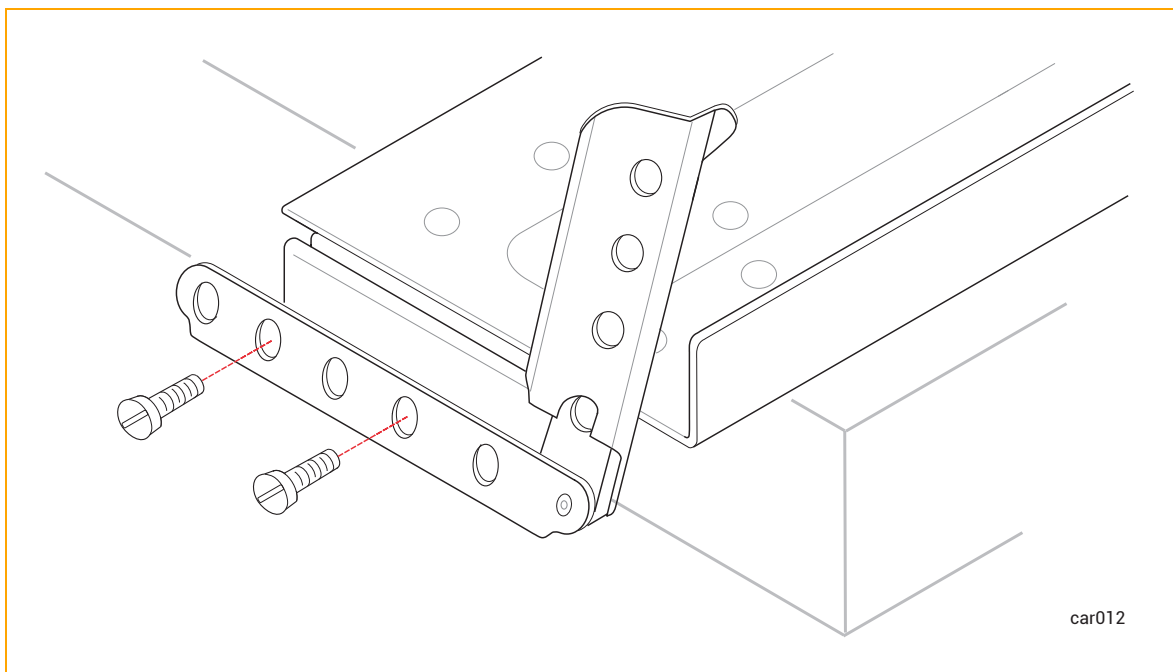

5. Repeat steps 3-4 for the rear latch.
6. Repeat steps 3-5 for the other support rail.

Next Steps

To continue installing a system in a cabinet, see ["Attaching the Support Rails and Inserting the System" on page 69](#).

Attaching the Support Rails and Inserting the System

After you have prepared the support rails for installation, attach the support rails to the vertical rails in the cabinet, and then insert the system into the cabinet.

To attach the support rails

1. Hold the support rail labeled **FRONT LEFT** and face the front of the cabinet.
2. Align the silver alignment screws in the front of the left support rail with the 2U holes that you marked in ["Numbering the Vertical Rails" on page 64](#) (that is, the third hole of the first U and the second hole of the second U). Close the latch. See [Figure 3-6](#).

Figure 3-6: Securing Front of Support Rail

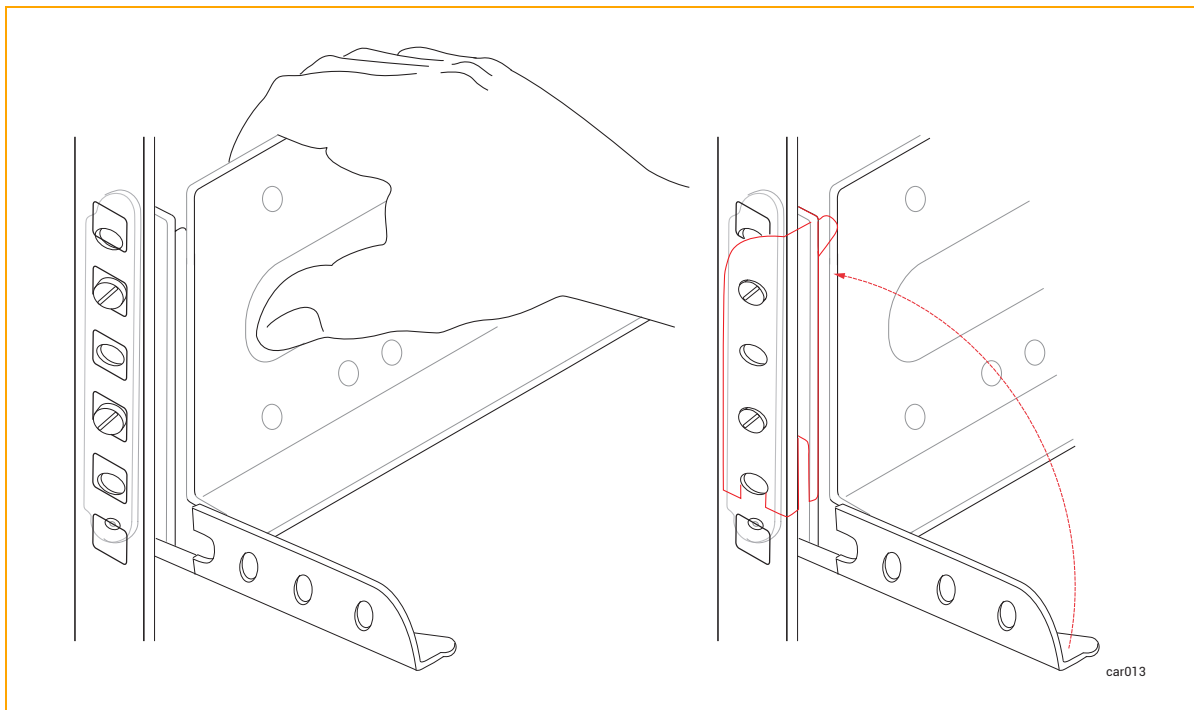

3. Moving to the rear of the cabinet, align the silver alignment screws in the rear of the left support rail with the 2U holes that you marked in ["Numbering the Vertical Rails" on page 64](#). Adjust the

support rail as necessary to fit the depth of the cabinet and close the latch.

4. Secure the rear of the rail by using a Phillips-head screwdriver to attach two black Phillips-head/hex screws in the holes below the silver alignment screws. See [Figure 3-7](#).

Figure 3-7: Securing Rear Support Rail

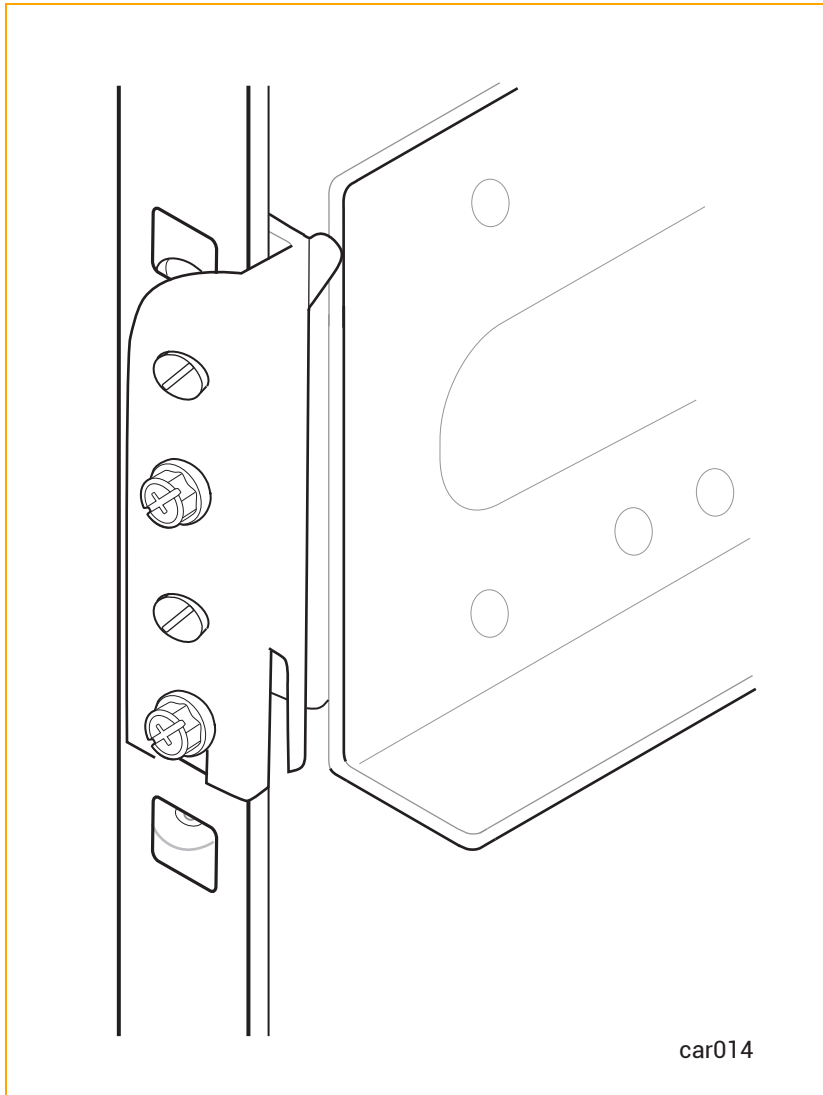

Perform steps 1-4 for the right support rail.

To insert the system in a cabinet



Notice: [Remove the compute modules](#) before you install the system in a cabinet. Doing so reduces the overall weight of the system, making the system easier to lift and install.



Caution: To avoid personal injury or damage to the system, up to three persons may be needed to insert the system in a cabinet.



Précaution: Pour éviter toute blessure corporelle ou tout dommage à l'étagère, au moins trois personnes sont fortement recommandées pour insérer l'étagère dans l'armoire et sur les supports de montage.

1. With one person on each side of the system and (ideally) one person in the front of the system, align it in the front cabinet opening and place it on the mounting rails.
2. Slide the system into the cabinet until the left and right ears are flush with the cabinet rails. See [Figure 3-8](#).

Figure 3-8: Inserting System into Cabinet

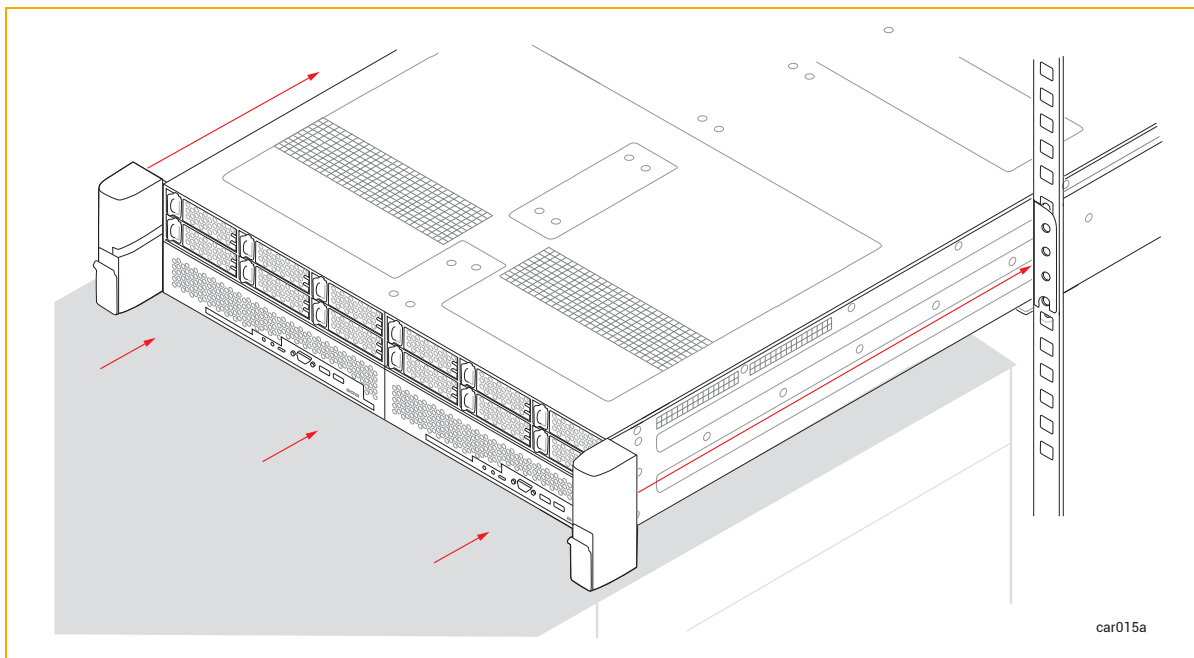

3. On the right ear, pull down the latch and use the Phillips-head screwdriver to secure the captive screw to the rail. Securing this captive screw fastens the system chassis and the front rail to the vertical rail of the cabinet. See [Figure 3-9](#).

Figure 3-9: Attaching Captive Screws

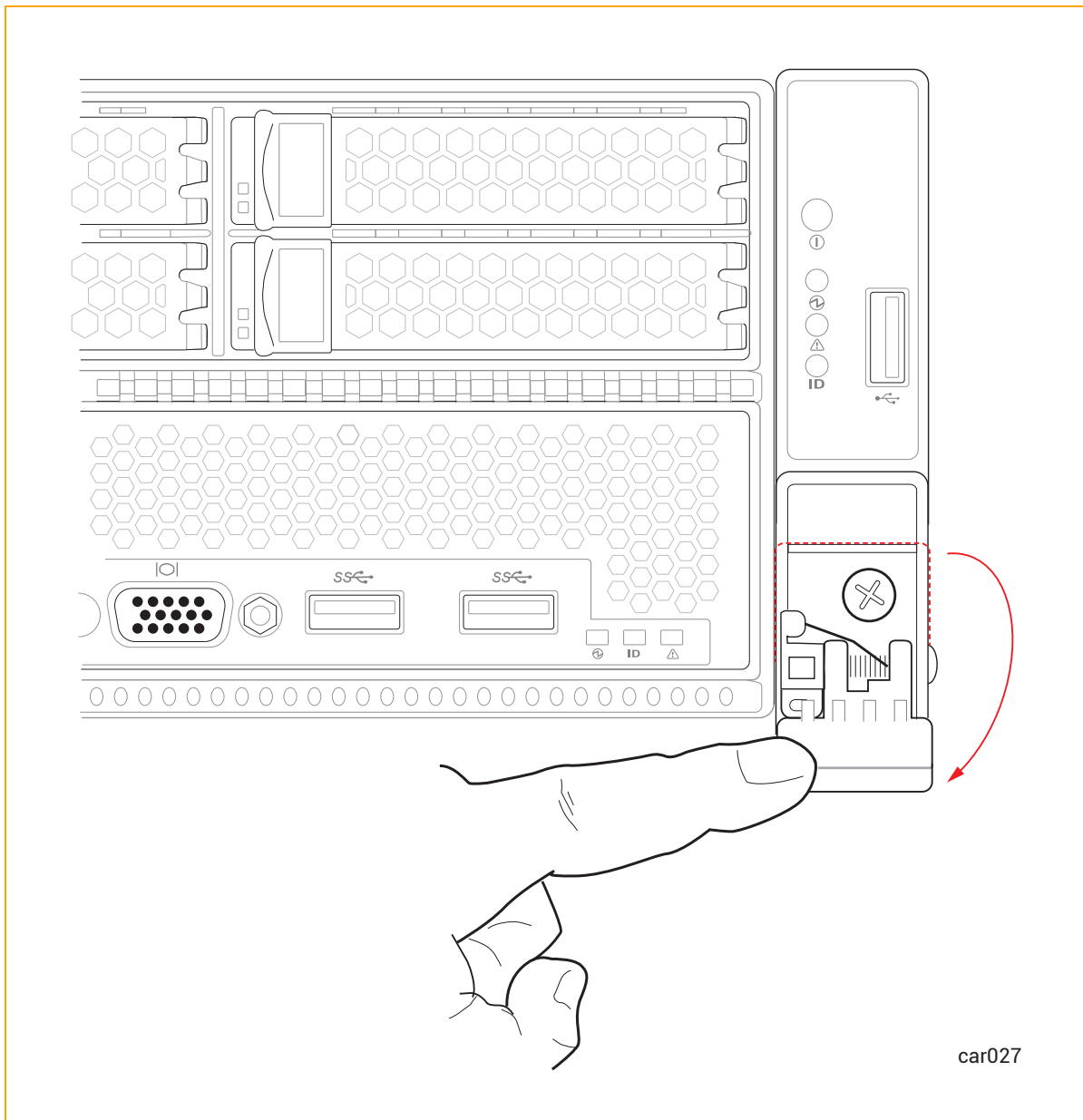

4. Repeat step 3 for the left ear.

Next Steps

Complete the hardware set-up, as described in ["Completing the Hardware Set-up" on page 72.](#)

Completing the Hardware Set-up

After you install the ztC Endurance system hardware, complete the system hardware set-up:

["I. Connect Network Cables" on page 73](#)

"II. Connect a Mouse, Keyboard, and Monitor" on page 74

"III. Connect the System to Electrical Power" on page 76

"IV. Insert Blank Disks into Storage Modules" on page 82

No tools are required for these tasks.

Note: When routing cables within the cabinet, keep all power cords as separate as possible from peripheral and communication cables. For example, route all power cords on one side of the cabinet and all peripheral and communications cables on the other side of the cabinet, using the cable-management rings on your cabinet to constrain the cords and cables.

I. Connect Network Cables

In both I/O modules, connect network cables from the bottom two **10G PORT2** ports to a production network and from the **1G MGMT** port to a management network. [Figure 3-10](#) shows the location of the network ports on the rear of the system.

Figure 3-10: Location of Network Ports

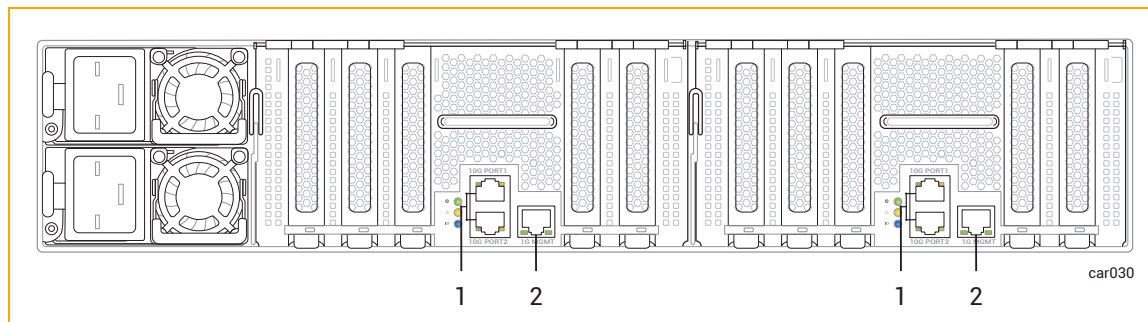

1	10G ports (4)
2	1G MGMT ports (2)

Notice: The installation process automatically configures the 10G ports into a default vSwitch to support the ESXi management network and virtual machines. To prevent installation problems, avoid modifying this configuration until after you have completed the installation process and finished verifying that the installation was successful, as described in ["Verifying the System Software Installation" on page 186](#). For example, do not add the ESXi host to a vSphere Distributed Switch (VDS) until the installation is complete and Automated Uptime Layer with Smart Exchange is running.

II. Connect a Mouse, Keyboard, and Monitor

To prepare for the software installation, connect two monitors (user-supplied) and two keyboards and mice (supplied by Penguin Solutions, if ordered) to ports on the system.

Notes:



1. Because the installation requires you to respond to prompts on both compute modules, connecting two monitors and keyboards means that you can view the activities on both compute modules simultaneously. If you can connect only one monitor and keyboard, you need to open a separate KVM console for each compute module.
2. Other keyboards and mice have not been tested and may not work properly.

For information about monitor and keyboard requirements, see ["Site Planning for Peripheral Components"](#) on page 50.

To connect a mouse, keyboard, and VGA monitor

1. Connect the USB cables from the mouse and keyboard to USB ports on a compute module (see [Figure 3-11](#)).



Notice: Do not connect the mouse or keyboard to the USB 2.0 port on the control-panel ear.

Figure 3-11: Location of VGA and USB Ports

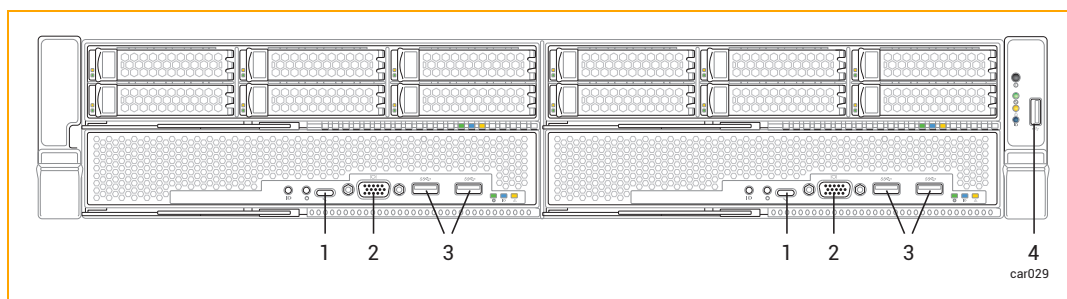

1	Debug ports (2)	3	USB 3.0 ports (4)
2	VGA (monitor port) (2)	4	USB 2.0 port (1)

2. Connect the 15-pin D-sub connector on the VGA cable from the monitor to the system's VGA port on a compute module (see [Figure 3-11](#)).
3. Connect the VGA cable to the monitor.

III. Connect the System to Electrical Power

For both power supply units (PSUs), connect power cords from the power inlets to supported power sources, and then fasten the power-cord retention strap. This strap helps prevent unintentionally disconnecting the power cord from the system if the system is removed from the cabinet.

For information about electrical power planning, see ["Electrical Power Planning" on page 40](#).

Warnings:



1. A ztC Endurance 31x0 or 51x0 system can operate in either the low-voltage or high-voltage range (see ["System Specifications" on page 293](#) for details). Make sure you are using power cords that have the correct voltage range and that are rated for your country. If you are changing to a different voltage range, follow the instructions described in [To replace both power cords](#).
2. Both PSUs in a ztC Endurance system must operate in the same voltage range.

Avertissements:



1. Le système ztC Endurance 31x0 ou 51x0 peut fonctionner en basse ou haute tension (voir les spécifications du système pour plus de détails). Assurez-vous que vous utilisez des cordons d'alimentation dont la plage de tension est correcte et qui sont adaptés à votre pays. Si vous passez à une plage de tension différente, suivez les instructions décrites dans la section [Pour remplacer les deux cordons d'alimentation](#).
2. Les deux blocs d'alimentation d'un système ztC Endurance doivent fonctionner dans la même plage de tension.

To connect the system to AC power mains

1. From the front and back of the system, make sure that all modules and PSUs are fully inserted.
2. Locate the two power cords for the system.
3. Connect the female end of the A-side power cord to the top PSU, as shown in [Figure 3-12](#). Connect the other end to the A-side power source.

4. Connect the female end of the B-side power cord to the bottom PSU, as shown in [Figure 3-12](#). Connect the other end to a second, separate, B-side power source.

Figure 3-12: Connecting a System Directly to AC Power

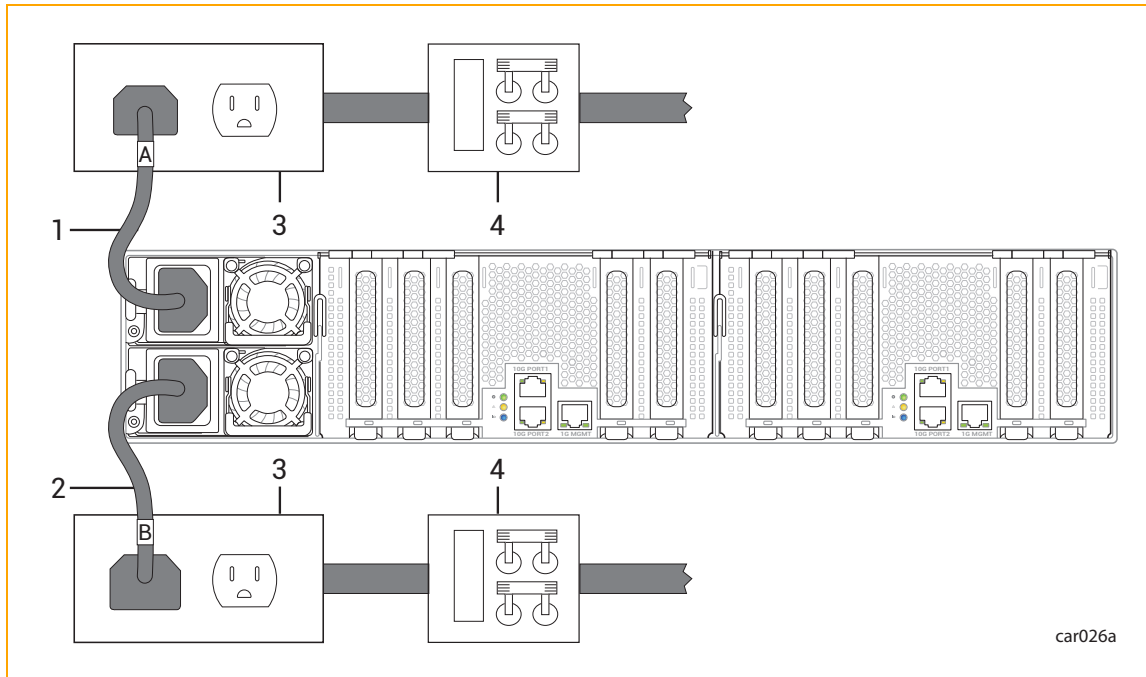

1	A-side power cord	3	AC power outlets
2	B-side power cord	4	AC power (mains) distribution circuit breakers (maximum of 20A)

To fasten the power-cord retention strap

1. Locate the power-cord retention strap on PSU A, the upper PSU at the rear of the system, as shown in [Figure 3-13](#).

Figure 3-13: Locating the Power-Cord Retention Strap

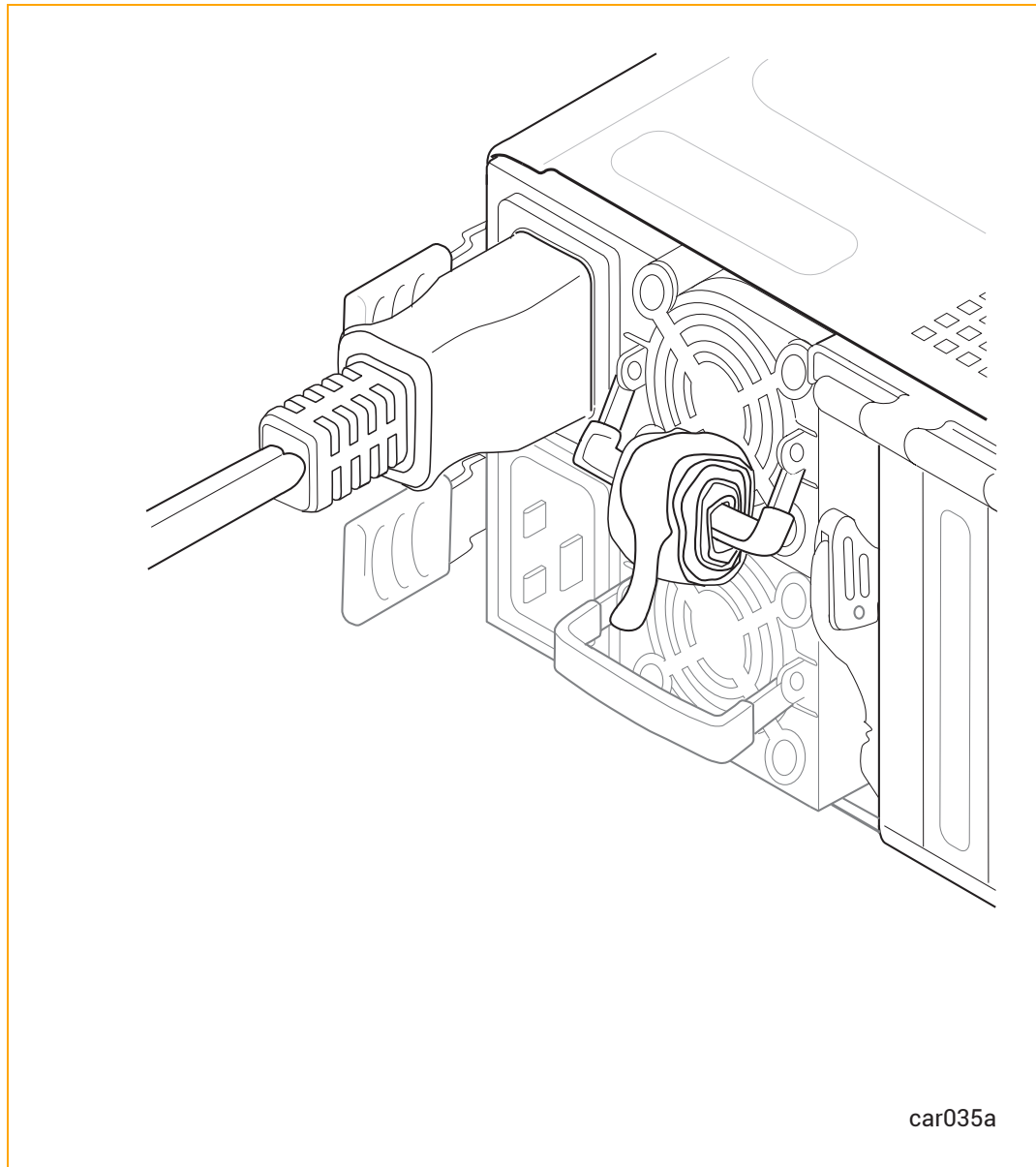

2. Pull on the end of the coiled strap to extend it, as shown in [Figure 3-14](#).

Figure 3-14: Extending the Power-Cord Retention Strap

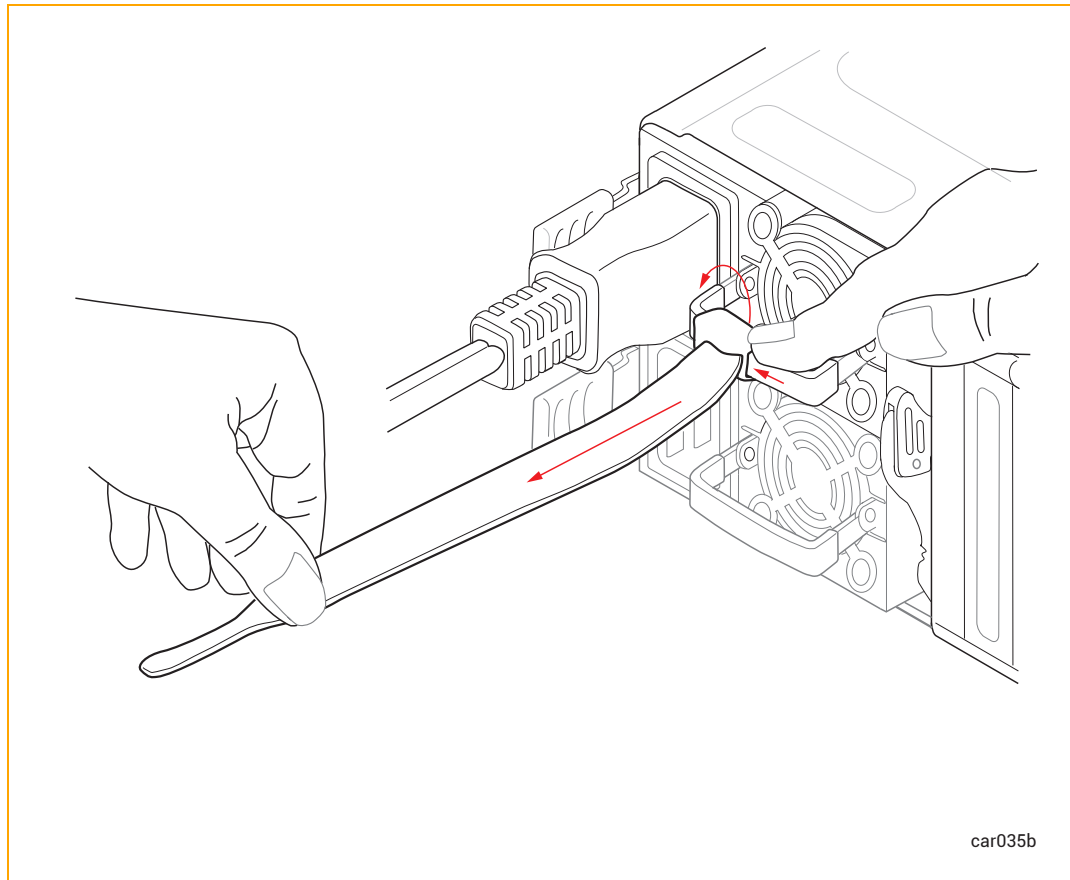

3. Wrap the strap tightly against the molded rib of the power cord to prevent the power cord from moving, as shown in [Figure 3-15](#).

Figure 3-15: Installing the Power-Cord Retention Strap

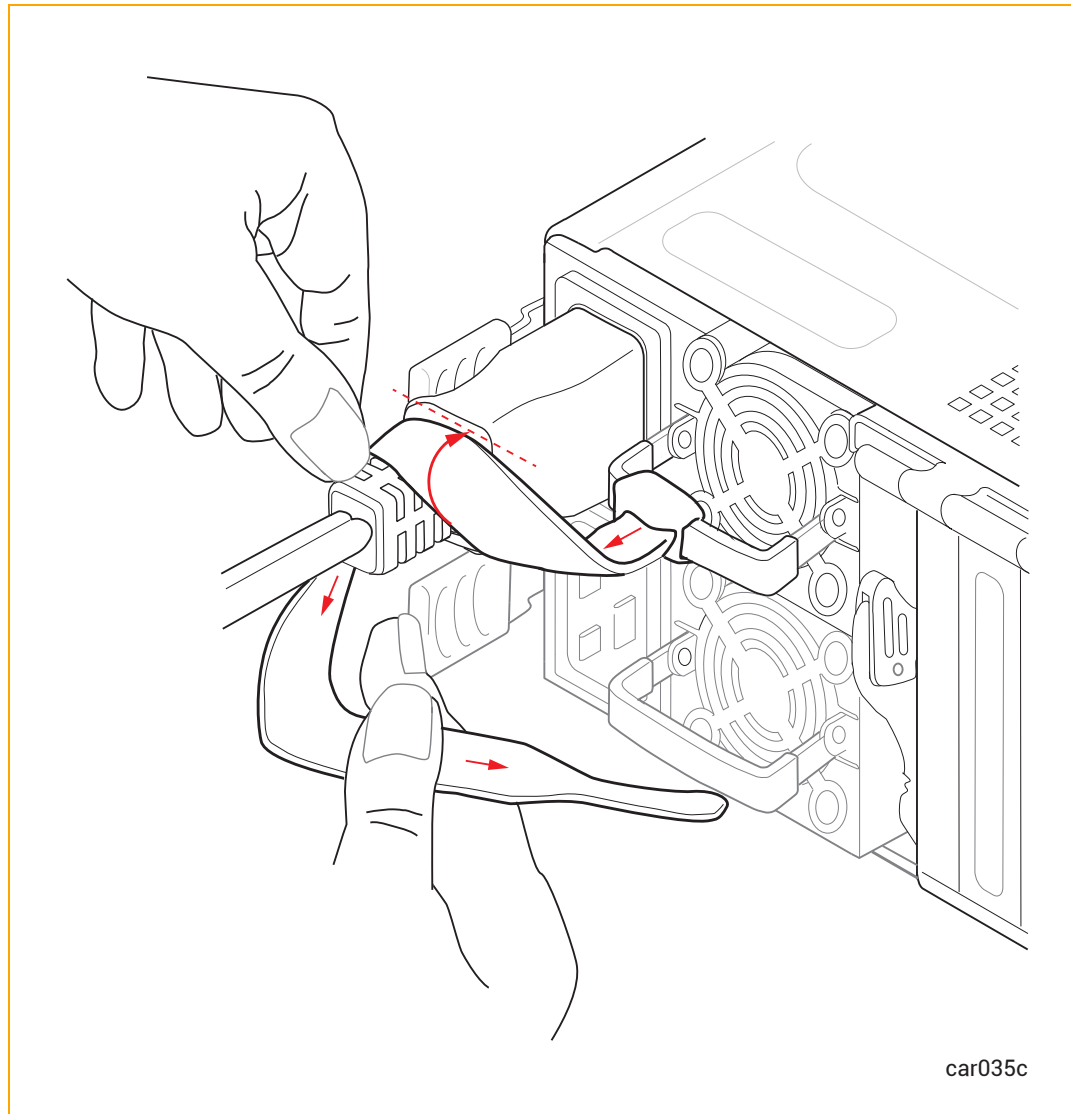

4. Continue wrapping the strap around the power cord until the strap is tightly in place, as shown in [Figure 3-16](#).

Figure 3-16: Correct Installation of the Power-Cord Retention Strap

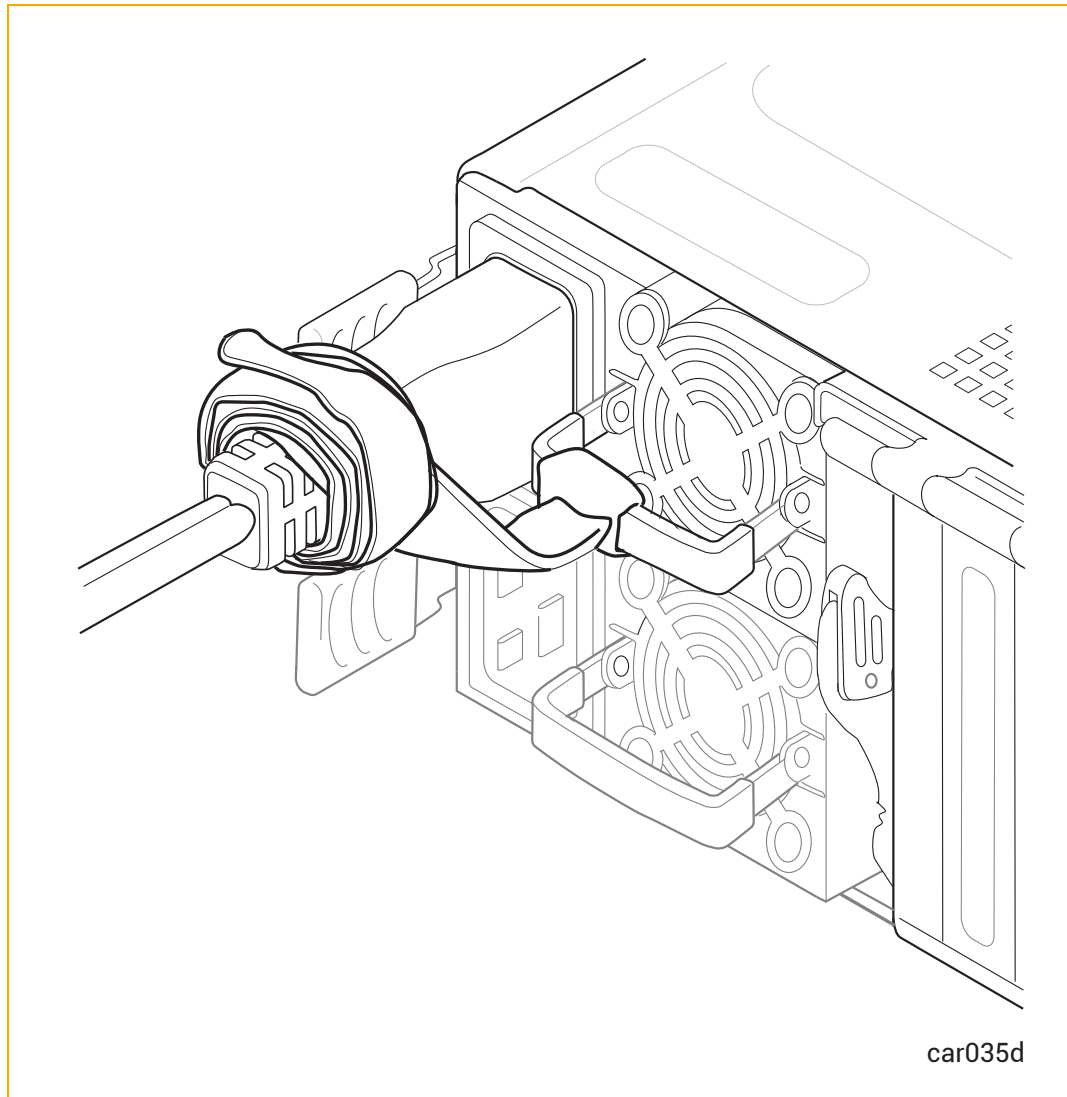

5. Repeat this procedure on PSU B, the lower PSU.

IV. Insert Blank Disks into Storage Modules

Insert a blank disk into the top-left slot of each storage module to install as system disks. (See ["Disk Drives" on page 28](#) if you need additional information.) These disks should have the same model, firmware level, and geometry.



Notice: At this time, do not install any disks that contain data in order to prevent possible problems.

Next Steps

Install the system software, as described in ["Installing the System Software" on page 149](#).

4

Chapter 4: Operating the ztC Endurance System Hardware

To learn more about operating and troubleshooting the ztC Endurance hardware, see:

- ["Hardware Operation" on page 83](#)
- ["Troubleshooting the Hardware" on page 89](#)

Hardware Operation

To learn more about operating the ztC Endurance hardware, see:

- ["Standby Power" on page 83](#)
- ["System Power" on page 84](#)
- ["Fan Speed" on page 89](#)

Related Topics

- ["Troubleshooting the Hardware" on page 89](#)

Standby Power

When one or both of the PSU power cords are connected to live power outlets, low-level standby power is present in the system. Standby power enables the primary Baseboard Management Controller (BMC) to monitor the status of system components, even when the system power is off.



Note: When you apply external power to the system, the BMC takes approximately 2 minutes to initialize. During this time, standby power, status LEDs, and the remote BMC cannot operate. The system power button may be able to operate before the BMC is fully initialized.

Standby power also allows for continuous operation of the ports used for the BMC: the 1G management ports (see "[System Ports](#)" on page 19). Therefore, while the system power is off, administrators (or, if authorized, Penguin Solutions Customer Service) can still connect to the system through the 1G management ports to diagnose problems, or to turn system power on and off from a remote location.



Warning: Standby power remains present even after the system has been powered down. To remove power to the standby devices, remove the power cords.



Avertissement: Une alimentation de réserve reste présente même après l'extinction du système. Pour couper l'alimentation des appareils de réserve, enlever les cordons d'alimentation.

Related Topics

- "[System Power](#)" on page 84
- "[System Ports](#)" on page 19
- "[PSUs](#)" on page 35

System Power

ztC Endurance systems have one power button located on the control-panel ear. Press this button to start the system.

Pressing the Power Button

The system power button functions as follows, assuming both compute modules are in the same state:



Note: The power button affects both compute modules. Therefore, if one compute module is powered off and one is booted, pressing the power button results in one compute module turning on and the other shutting down.

- If the system power is off and standby power is on, pressing the power button turns the system on and boots the operating system. See "[Starting Up the System](#)" on page 85.
- If the operating system hangs or a hardware failure occurs, pressing the power button for several seconds (a "long press") initiates a forced system shutdown, which includes an abrupt shutdown of the VMs. (Standby power remains on.) If possible, use VMware tools to stop VMs before you initiate a forced system shutdown.

Starting Up the System

Make sure the system power cords are plugged into a live power source.

To boot a system and start the operating system

1. Turn on the monitor.
2. Press the power button on the control-panel ear. See [Figure 4-1](#).

Figure 4-1: Power Button

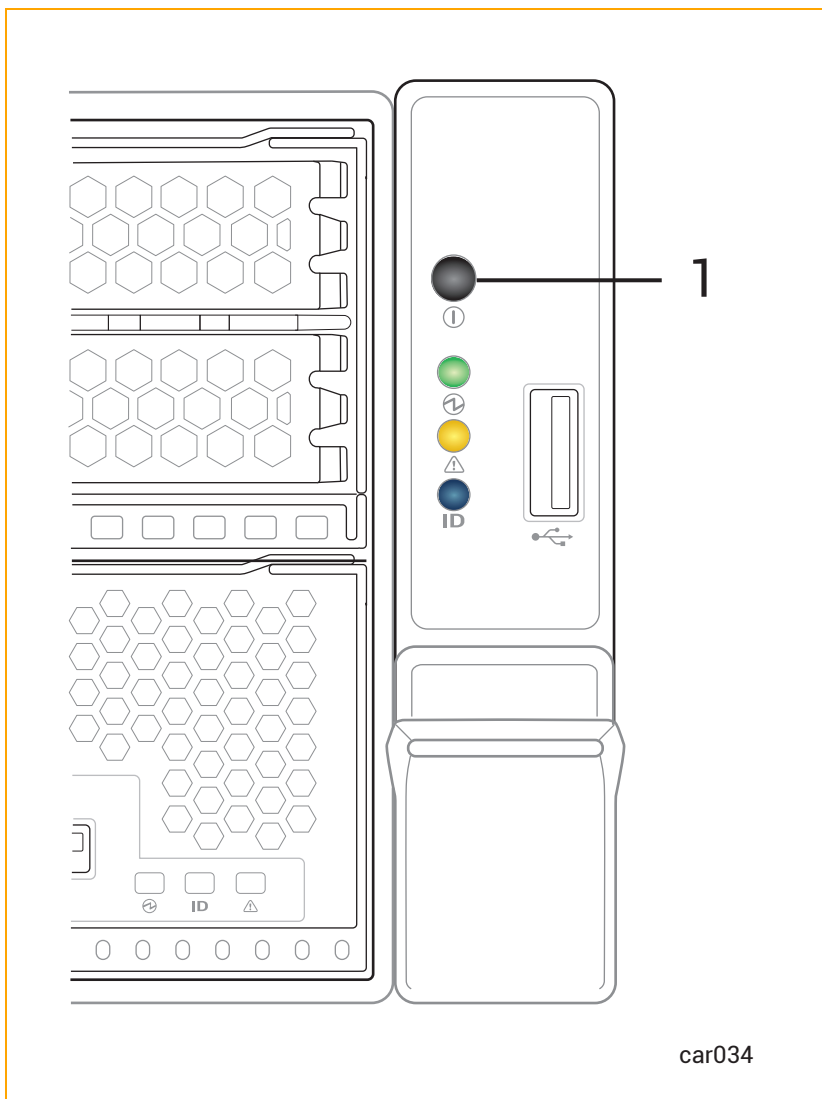

1 Power button

Shutting Down the System



Warning: The system's standby devices have power even after the system has been powered down. To remove power to the standby devices, you must remove the power cords.



Avertissement: Les appareils de réserve du système restent alimentés même après l'extinction du système. Pour couper l'alimentation des appareils de réserve, vous devez enlever les cordons d'alimentation.

Exit from all applications before shutting down a system.

To shut down a VMware vSphere-based system

Notices: Before you shut down the system, consider the impact on your virtual machines. You might want to migrate or shut down the virtual machines before shutting down the system:

- If you manually shut down the virtual machines, shut down only your virtual machines and then power off the system as described below. The Management VM will shut down automatically.
- If you want the virtual machines to start up and shut down automatically when you start up and shut down the ztC Endurance system, you must explicitly configure these settings in the **Autostart** or **Virtual Machine Startup/Shutdown** properties for the ESXi host, as described in the VMware vSphere documentation.



For additional information about the proper startup and shutdown of virtual machines, see the information below.

Notice: To properly shut down the system, use only methods provided by ztC Endurance and Automated Uptime Layer with Smart Exchange; only these methods will properly shut down both the active compute module and the standby compute module that monitors system health for continuous uptime.



If you attempt to shut down the system by using vSphere Web Client, ESXi Host Client, ESXi Shell commands, or F12 on the ESXi home screen, the standby compute module will remain running, which prevents shutdown. When the standby OS detects that the active compute module is down, the standby module automatically takes ownership of the system devices, assumes the role of the active compute module, and restarts the ESXi host.

To shut down a VMware vSphere-based system gracefully, click **Shutdown** on the **Dashboard** page of the ztC Endurance console.

When you shut down a VMware vSphere-based system, note that the following behavior is normal:

- The system stays powered on for two minutes, as all services are stopped and cached data is written to disk.

- If VMs are running, shutdown could take longer than a minute or two. If the VMs are scheduled to suspend on system shutdown, it can take even longer, depending on how many VMs are running and how much memory they have been assigned.
- The Ethernet activity and connection-speed LEDs for embedded Ethernet ports may remain lit even when the system is powered down, if Wake On LAN is enabled in the system BIOS (see "Enabling and Disabling Wake on LAN" on page 88).



Note: Wake On LAN is supported only for the host's or BMC's connection to the 1G management network.

When you configure the startup and shutdown properties for virtual machines, note the following guidelines:

- Only guest operating systems that support the VMware Tools and have these tools installed will shut down properly when the ESXi host shuts down. After modifying the virtual machine settings, you should test your configuration and verify that your guest operating systems start up and shut down as expected.
- If the guest operating system in a virtual machine hangs while shutting down, it does not prevent the ESXi host from shutting down. However, if you configure an uninterruptible power supply (UPS) with the system, you should set shutdown delays short enough to prevent the UPS battery from becoming depleted before the ESXi host itself shuts down.
- Do not modify the virtual machine settings for the Management VM. The Management VM is already properly configured to start and stop with the ESXi host. Do not shut down or power off the Management VM itself while the system is running, unless instructed to do so by your authorized Penguin Solutions service representative.

Enabling and Disabling Wake on LAN

The Wake On LAN (WOL) networking standard allows a computer to be turned on or awakened from sleep mode remotely via a network message.

The following instructions allow you to enable or disable WOL for ports on your ztC Endurance system.



Notice: Do not change any other BIOS settings unless Penguin Solutions Customer Service has advised you to do so.

To enable WOL

1. As the system starts to boot, press either the `Delete` key or the `Esc` key until the system BIOS setup utility appears.
2. When the utility screen appears, use the arrow keys to go to the Advanced menu.
3. Select Intel(R) i210 Gigabit Backplane Connection and press `Enter`.
4. Select NIC Configuration and then select the port that you want to enable. Press `Enter`.
5. Use the `+/=` keys to change Wake On LAN to Enabled and press `Enter`.
6. Press `F4` to save your changes and exit the utility.

To disable WOL

1. Download the Intel® Ethernet Flash Firmware Utility (BootUtil) from the following Web site:
<https://www.intel.com/content/www/us/en/support/articles/000005790/software/manageability-products.html>
2. Use the `-WOLDISABLE` or `-WOLD` option of BootUtil to disable WOL functionality on the selected port, as described in the preceding Web site.

Fan Speed

You might notice fan-speed increases in high-temperature environments, during high system activity periods, while loading the operating system software, shutting down the system, or restarting the operating system. The increase in fan speed ensures adequate cooling under these conditions and is normal behavior.

Related Topics

- ["Troubleshooting the Hardware" on page 89](#)

Troubleshooting the Hardware

To learn more about troubleshooting the ztC Endurance hardware, see:

- ["Status LEDs" on page 90](#)
- ["Internal Disk Drive Problems and Solutions" on page 99](#)
- ["Using the NMI Button" on page 100](#)

Related Topics

- ["Hardware Operation" on page 83](#)

Status LEDs

Status LEDs are located on the control-panel ear as well as the front of each CRU module. This topic illustrates and describes these LEDs. See [Figure 4-2](#) and [Figure 4-3](#), as well as [Table 4-1](#), [Table 4-2](#), [Table 4-3](#), [Table 4-4](#), and [Table 4-5](#).

You can use the ATTN LEDs to diagnose faults, as described in "Using the ATTN LEDs to Diagnose Faults" on page 97.

Figure 4-2: Front LEDs: Storage Module, Control-panel Ear, and Compute Module

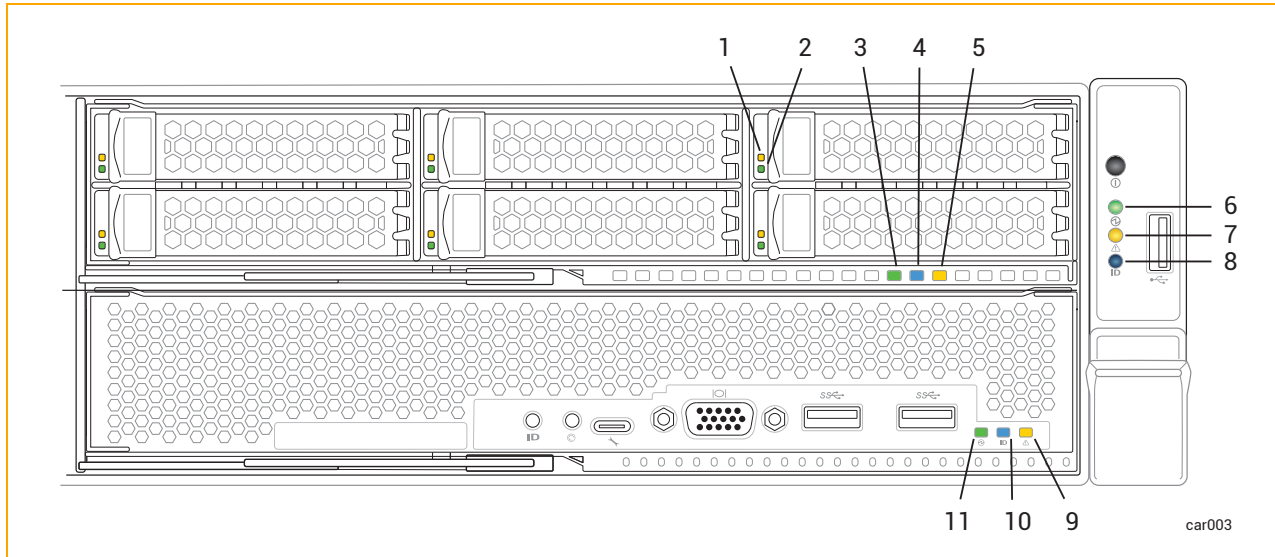

Table 4-1: Front LEDs: Storage Module

Callout	LED	State	Description
1	Fault	Off	Normal operation.
		Solid amber	The disk is broken and safe to remove. See "Removing and Inserting a Disk Drive" on page 118.
2	ACT	Off	For 6.4 TB disks, indicates that the disk is present but idle.
		Solid green	For 1.6 TB or 3.2 TB disks, indicates that the disk is present but idle.
		Blinking green	Data is being written to or read from the disk.

Table 4-1: Front LEDs: Storage Module

Callout	LED	State	Description
3	PWR	Off	DC power and standby power to the module are off.
		Solid green	DC power to the module is on.
		Blinking green	Standby power to the system is on; DC power to the module is off.
4	UID	Off	No request to identify module activated (normal operation). To identify, see "Identifying a System or Component" on page 238 .
		Solid blue	Request to identify module activated; LED illuminates with DC power or with standby power.
5	ATTN	Off	Indicates one of two scenarios: <ul style="list-style-type: none"> • The module does not need to be replaced. • The module needs to be replaced, but the module is not safe to remove. To determine which scenario is true, check the control-panel ear's ATTN LED. If that LED is not illuminated, no module in the system needs to be replaced.
		Blinking amber	Fault; safe to replace the module. LED illuminates with DC power or with standby power. To replace, see "Removing and Replacing a Storage Module" on page 116 .

Table 4-2: Front LEDs: Control-Panel Ear

Callout	LED	State	Description
6	PWR	Off	DC power and standby power to the module are off. To turn power on or off, press the power button on the control-panel ear or use the BMC. See " System Power " on page 84.
		Solid green	DC power to any module is on.
		Blinking green	Standby power is on; no module has DC power.
7	ATTN	Off	Indicates one of two scenarios: <ul style="list-style-type: none"> Standby power is off. Standby power is on, but no compute module is inserted.
		Solid green	Indicates one of two scenarios: <ul style="list-style-type: none"> Standby power is on, at least one compute module is inserted, but the ztC Endurance Management VM is not running. The ztC Endurance Management VM is running, all modules are present, and no modules need replacement.
		Blinking amber	Indicates one of three scenarios: <ul style="list-style-type: none"> The ztC Endurance Management VM is running, and one or more modules are not inserted or need replacement. One member of a teamed PCIe adapter or Fibre Channel cable has been removed. A disk drive is missing from a mirrored pair, either because of physical

Table 4-2: Front LEDs: Control-Panel Ear

Callout	LED	State	Description
			<p>removal or because it is below MTBF.</p> <p>Check LEDs of all modules to identify the module with a fault. For a list of modules, see "System CRU Modules" on page 20.</p> <div style="border: 1px solid #00FFFF; padding: 10px; margin-top: 10px;"> <p>Note: After a total system shutdown, the ATTN LED remains in the last state it was in until you remove and restore standby power.</p> </div>
8	UID	Off	<p>No request to identify module activated (normal operation).</p> <p>To identify, see "Identifying a System or Component" on page 238.</p>
		Solid blue	<p>Request to identify module activated; LED illuminates with DC power or with standby power.</p>

Table 4-3: Front LEDs: Compute Module

Callout	LED	State	Description
9	ATTN	Off	<p>Indicates one of two scenarios:</p> <ul style="list-style-type: none"> The module does not need to be replaced. The module needs to be replaced, but the module is not safe to remove. <p>To determine which scenario is true, check the control-panel ear's ATTN LED. If that LED is not illuminated, no module in the system needs to be replaced.</p>
		Blinking amber	<p>Fault; safe to replace the module. LED</p>

Table 4-3: Front LEDs: Compute Module

Callout	LED	State	Description
			illuminates with DC power or with standby power. See "Removing and Replacing a Compute Module" on page 107.
10	UID	Off	No request to identify module activated (normal operation). To identify, see "Identifying a System or Component" on page 238.
		Solid blue	Request to identify module activated; LED illuminates with DC power or with standby power.
11	PWR	Off	The module's DC power is off, and the other compute module's DC power is on.
		Solid green	The module has DC power (standby power is also on).
		Blinking green	The system has standby power only.

Figure 4-3: Rear LEDs: PSUs and I/O Module

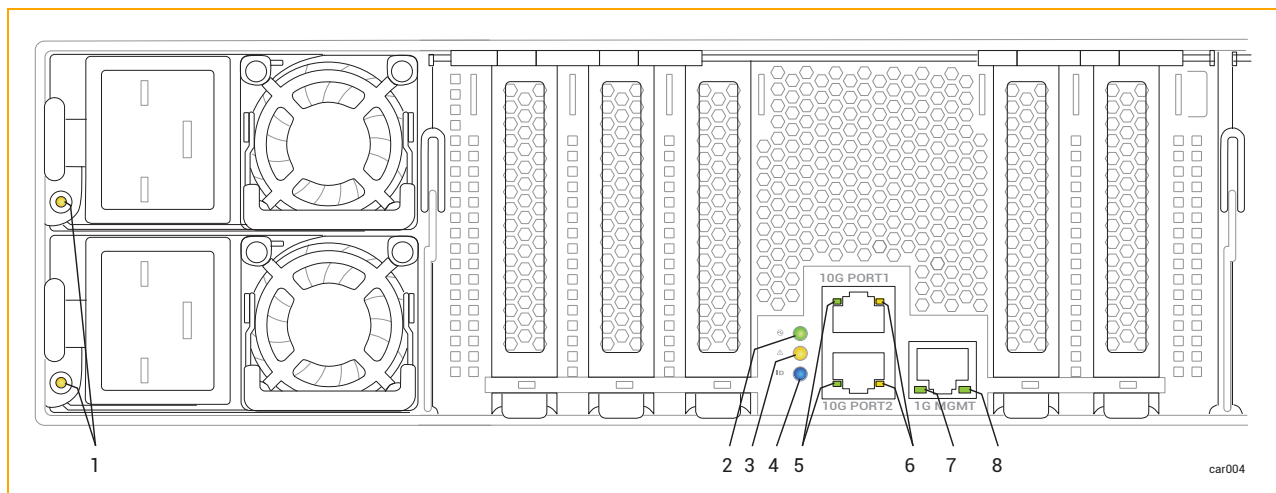

Table 4-4: Rear LEDs: PSUs

Callout	State	Description
1	Off	No AC power to any PSU.
	Solid green	Output power is on.
	Blinking green (1Hz)	The PSU is in a standby state: AC power is present at only 12Vsb.
	Blinking green (2Hz)	PSU firmware is updating.
	Solid amber	Indicates one of two scenarios: <ul style="list-style-type: none"> The PSU has lost AC power (the AC cord might be unplugged); a second PSU still has AC power. A PSU critical event is causing a shutdown because of a failure, overcurrent, short circuit, over-voltage, fan failure, over-temperature, or some other reason.
	Blinking amber (1Hz)	The PSU is still operating, though it is experiencing a warning event such as a high temperature, high power, high current, or a slow fan.

Table 4-5: Rear LEDs: I/O Module

Callout	LED	State	Description
2	PWR	Off	DC power and standby power to the module are off.
		Solid green	DC power to the module is on.
		Blinking green	Standby power to the system is on; DC power to the module is off.
3	ATTN	Off	Indicates one of two

Table 4-5: Rear LEDs: I/O Module

Callout	LED	State	Description
			<p>scenarios:</p> <ul style="list-style-type: none"> • The module does not need to be replaced. • The module needs to be replaced, but the module is not safe to remove. <p>To determine which scenario is true, check the control-panel ear's ATTN LED. If that LED is not illuminated, no module in the system needs to be replaced.</p>
		Blinking amber	<p>Fault; safe to replace the module. LED illuminates with DC power or with standby power.</p> <p>To replace, see "Removing and Replacing an I/O Module" on page 123.</p>
4	UID	Off	<p>No request to identify module activated (normal operation).</p> <p>To identify, see "Identifying a System or Component" on page 238.</p>
		Solid blue	<p>Request to identify module activated; LED illuminates with DC power or</p>

Table 4-5: Rear LEDs: I/O Module

Callout	LED	State	Description
			with standby power.
5	10 Gbps Link /ACT	Off	No link is present.
		Solid green	Link is stable.
		Blinking green	Data is being transferred over the link.
6	10 Gbps Speed	Off	No link is present.
		Solid green	Connection speed is 10 Gbps.
		Solid amber	Connection speed is less than 10 Gbps.
7	1 Gbps Link /ACT	Off	No link is present.
		Solid green	Link is stable.
		Blinking green	Data is being transferred over the link.
8	1 Gbps Speed	Off	No link is present, or link speed is less than 1 Gbps.
		Solid green	Connection speed is 1 Gbps.

Using the ATTN LEDs to Diagnose Faults

The ATTN LED on the control-panel ear and on the CRU modules help you diagnose faults. A *fault* is an issue that requires module replacement, as opposed to other types of errors that occur on a module (for example, correctable errors below a certain threshold) that do not require module replacement.

The examples in [Table 4-6](#) provide more information about using the ATTN LEDs to diagnose faults.

Table 4-6: Examples of Faults

ATTN LED Status	Explanation
<p>Control-panel ear ATTN LED is blinking amber.</p> <p>For all modules, ATTN LEDs are off.</p>	<p>One or more of the modules needs replacement or is not inserted, but no module that needs replacement is safe to remove.</p> <p>For example, compute module A may need replacement, but it may still be the active compute module.</p>
<p>Control-panel ear ATTN LED is blinking amber.</p> <p>Compute module A ATTN LED is blinking amber.</p> <p>For all other modules, ATTN LEDs are off.</p>	<p>Compute module A needs replacement, and it is safe to remove. One or more of the other modules may need replacement or may not be inserted, but no module that needs replacement is safe to remove.</p> <p>For example, storage module A may need replacement, but it may contain a non-mirrored disk.</p>
<p>Control-panel ear ATTN LED is blinking amber.</p> <p>I/O module B ATTN LED is blinking amber.</p> <p>For all other modules, ATTN LEDs are off.</p>	<p>I/O module B needs replacement, and it is safe to remove. One or more of the other modules may need replacement or may not be inserted, but no module that needs replacement is safe to remove.</p> <p>For example, compute module A may need replacement, but it may still be the active compute module.</p>

Related Topics

- ["Identifying a System or Component" on page 238](#)
- ["System Front" on page 17](#)
- ["System Rear" on page 18](#)
- ["Planning a Site for ztC Endurance Systems" on page 37](#)
- ["Hardware Operation" on page 83](#)
- ["Removing and Replacing System Components" on page 101](#)
- ["Troubleshooting the Hardware" on page 89](#)

Internal Disk Drive Problems and Solutions

[Table 4-7](#) lists some problems that the disk drives may encounter, as well as some corrective actions.

Table 4-7: Troubleshooting Disk Drives

Problem	Action
System will not boot from system disk	Try to boot from the system disk's mirrored partner. To do so, disengage the suspected faulty system disk by pulling it one to two inches (2.5 to 5 cm) out of the slot. See "Removing and Inserting a Disk Drive" on page 118 for more information.
System does not recognize disk drive	Ensure that the disk drive was installed correctly. See "Removing and Inserting a Disk Drive" on page 118 for more information.
Slow response time	<p>Mirror regeneration might be occurring. Try to schedule mirror regeneration for a time when the system is not heavily used. However, if the disk contains business-critical data, you should regenerate the mirrors as soon as possible.</p> <p>Many read or write operations might be queued to the disk drive.</p> <p>Errors might be occurring on the drive. Check the system event log.</p>

Related Topics

- ["Disk Drives" on page 28](#)
- ["Storage Module" on page 27](#)
- ["Troubleshooting the Hardware" on page 89](#)

Using the NMI Button

To enable your authorized Penguin Solutions service representative to diagnose problems with your system, you might need to create a dump file of the system's memory while the system is running.

One way to create a dump file is to press the NMI button (see [Figure 1-5](#)) on the active compute module.



Notice: Pressing the NMI button stops any running applications. Do not perform a dump operation if you want any applications to continue operating. Instead, schedule downtime for this procedure.

You may need to press the NMI button more than once to generate the dump signal. However, do not press the NMI button while a dump is in progress. This may result in an unusable dump.

If the dump signal is generated on VMware vSphere-based systems, a purple screen appears on the monitor, displaying the number of the software components (for example, 3/9, indicating that it is dumping the contents associated with the 3rd of 9 components.) If the purple screen does not appear, the dump signal was not generated.

Related Topics

- ["System Front" on page 17](#)
- ["Compute Module" on page 21](#)

5

Chapter 5: Removing and Replacing System Components

You can remove and replace many of the components of a ztC Endurance system. Before you remove or replace any system components, see ["General Servicing Information" on page 101](#).

To remove and replace system components, see:

- ["Preparing to Replace System Components" on page 105](#)
- ["Removing and Replacing a Compute Module" on page 107](#)
- ["Replacing, Adding, and Upgrading Memory" on page 110](#)
- ["Removing and Replacing a Storage Module" on page 116](#)
- ["Removing and Inserting a Disk Drive" on page 118](#)
- ["Removing and Replacing an I/O Module" on page 123](#)
- ["Removing and Installing a PCIe Adapter" on page 126](#)
- ["Removing and Replacing a PSU and Power Cords" on page 130](#)

Related Topics

- ["System CRU Modules" on page 20](#)
- ["Troubleshooting the Hardware" on page 89](#)

General Servicing Information

To perform general servicing tasks related to the unpacking, storing and repacking of system components, see:

- "Unpacking System Components" on page 102
- "Storing System Components" on page 103
- "Repacking System Components" on page 103
- "Replacing System Components" on page 104
- "General Safety Precautions" on page 105

Unpacking System Components

When you receive a system component:

- Inspect the packing slip to ensure that the correct component was received.
- Inspect the packing container for damage.

Refer to the Warranty Parts Replacement Process and Return Instructions Web Site at <http://www.stratus.com/go/support/ftserver/warrantyreplace> if either of the following conditions applies to your shipment:

- You received the wrong shipment.
- The package is damaged.

If there are no problems, unpack the component.

To unpack a system component

1. Observing any printed directions or warnings, carefully open the package.
2. Carefully remove the protective packaging and save it for possible reuse in storing or returning a component.
3. Verify that you received the correct component by checking the packing slip and the bar code label on the component.
4. Inspect the component for shipping damage.
5. If the component is wrapped in an antistatic bag, keep it in the bag until it is installed. If you are not going to install the component immediately, protect it from damage by repacking it in its shipping package.

Related Topics

- "Removing and Replacing System Components" on page 101

Storing System Components

If you need to store a system component, keep it in the protective packaging and take the following precautions:

- Ensure that the component is right-side up by following the directions on the package.
- Comply with all warning labels.
- Avoid placing the component in a location where heavier items might be placed on it.
- Protect the component from exposure to dust, electromagnetic fields, vibrations, extreme heat, or any other environmental conditions that might damage the component.
- Avoid prolonged storage that could reduce the useful life of the component.

If you are uncertain about the proper storage conditions for a specific component, see ["Getting Help" on page 299](#). Also, see ["Preparing to Replace System Components" on page 105](#) for information about how to protect components from exposure to static electricity.

Related Topics

- ["Removing and Replacing System Components" on page 101](#)

Repacking System Components

When returning a defective or incorrect system component, package the component using the original packing materials or the replacement-component packing materials. Ensure that the component is adequately protected from the following:

- Dents, scratches, and impact damage
- Static electricity (using the pink or blue electrostatic discharge (ESD) bag)
- Accidental opening of the package in transit
- Detachment of the address label

If you are uncertain that the component will be adequately protected during shipment, see ["Getting Help" on page 299](#).

Related Topics

- ["Removing and Replacing System Components" on page 101](#)

Replacing System Components

Caution: Do not remove or service any I/O modules, storage modules, or compute modules if the ztC Endurance console is reporting any PSU faults.



You must first restore full PSU functionality to both PSUs before removing any other modules for additional service (that is, the LED on both PSUs must be solid green).

In extreme circumstances, failure to follow this service sequence may result in compromised power integrity to the ztC Endurance system.

Caution: Ne retirez ni ne procédez à l'entretien d'aucun module d'E/S, de stockage ou de calcul si la console ztC Endurance signale une défaillance d'un bloc d'alimentation.



Vous devez d'abord rétablir le bon fonctionnement des deux blocs d'alimentation avant de retirer tout autre module pour un entretien supplémentaire (autrement dit, les voyants DEL des deux blocs d'alimentation doivent rester allumés en vert sans clignoter).

Dans des situations extrêmes, le non-respect de cette séquence d'entretien risque de compromettre l'intégrité de l'alimentation électrique du système ztC Endurance.

Before replacing a system component, do the following:

- Confirm that the component has failed and needs to be replaced. You can view failure information from the status LEDs on each component, from your system's event or error logs, and from viewing the **Dashboard** page of the ztC Endurance console.
- Determine if a component needs to be taken out of service, and then remove it from service as described in ["Using Maintenance Mode" on page 239](#).
- Observe the proper safety precautions by following the precautions listed in ["General Safety Precautions" on page 105](#).

After replacing a component, do the following:

1. Place the component in service if it is out of service as described in ["Using Maintenance Mode" on page 239](#).
2. Verify system operation.
3. Package and ship the failed component. See ["Repacking System Components" on page 103](#).

Related Topics

- ["Removing and Replacing System Components" on page 101](#)
- ["Status LEDs" on page 90](#)
- ["Dashboard Page" on page 229](#)

General Safety Precautions

- To help identify problems that might occur during the removal and replacement of system components, read the entire procedure before performing it.
- Provide enough space and light to perform the procedure safely and accurately.
- Conduct all activities in compliance with all applicable industry safety standards and practices.
- Take proper grounding precautions. When handling components, especially those with exposed integrated circuits, use proper grounding procedures to avoid ESD damage to the component. See the information about using ESD precautions in ["Safety Precautions" on page 51](#).
- When performing maintenance procedures, do not wear conductive articles or material such as rings, bracelets, keys, chains, garments with metallic thread, and other similar items.

Related Topics

- ["Safety Precautions" on page 51](#)

Preparing to Replace System Components

No tools are required to replace customer-replaceable components in a ztC Endurance system.

Working on the physical system can expose electronic components to potential damage from electrostatic discharge (ESD). Whenever working on a system:

- [Use ESD precautions.](#)
- [Observe all notes, notices, cautions, and warnings.](#)

Using ESD Precautions

Notices: To avoid damaging ESD-sensitive components during handling, always take the following precautions.



- Ground yourself before working with system components. Put a grounding strap on your wrist and attach its other end to some suitable grounding point, such as a computer-system cabinet.
- Discharge static electricity by touching an unpainted portion of the system just before handling ESD-sensitive parts.
- Store PCIe adapters in their static-protective envelope until you are ready to install them in the system.
- Hold a PCIe adapter by its edges.

Observing Cautions and Warnings

Observe the following warnings, cautions, notices, and notes.



Warning: If a component is not customer-replaceable, do not attempt to remove or replace it. Doing so may result in serious personal injury and/or damage to the system.



Avertissement: Si un composant n'est pas remplaçable par le client, n'essayez pas de le retirer ou de le remplacer. Cela pourrait provoquer des blessures graves et/ou endommager le système.

Notices: When replacing a system component, always observe the following guidelines.



- Remove a component only when its status LEDs indicate that it is safe to remove. See "[Status LEDs](#)" on page 90 for information about each component's status LEDs.
- When necessary, see "[Status LEDs](#)" on page 90 to learn how to identify a failed component and take it offline before servicing it.
- Read the entire procedure so that you fully understand it. If any part of the procedure is not clear, see "[Getting Help](#)" on page 299.

Related Topics

- ["Safety Precautions" on page 51](#)
- ["General Safety Precautions" on page 105](#)

Removing and Replacing a Compute Module

Cautions:



1. Use [ESD precautions](#) when performing these procedures.
2. Read ["Replacing System Components" on page 104](#) before you remove any system components.

Précautions:



1. Utilisez les précautions ESD lors de l'exécution de ces procédures.
2. Lisez ["Replacing System Components" on page 104](#) avant de retirer des composants du système.

To remove a compute module

1. Place the compute module into maintenance mode as described in ["Using Maintenance Mode" on page 239](#).
2. After the compute module is in maintenance mode, shut it down as described in ["Shutting Down and Restarting a Compute Module" on page 241](#).
3. Disconnect all cables from the compute module.
4. Use your index finger to unlatch the release lever on the compute module.
5. Grasp the release lever and pull it away from the system chassis until the module extends an inch or two from the system chassis. See [Figure 5-1](#).

Figure 5-1: Removing Compute Module

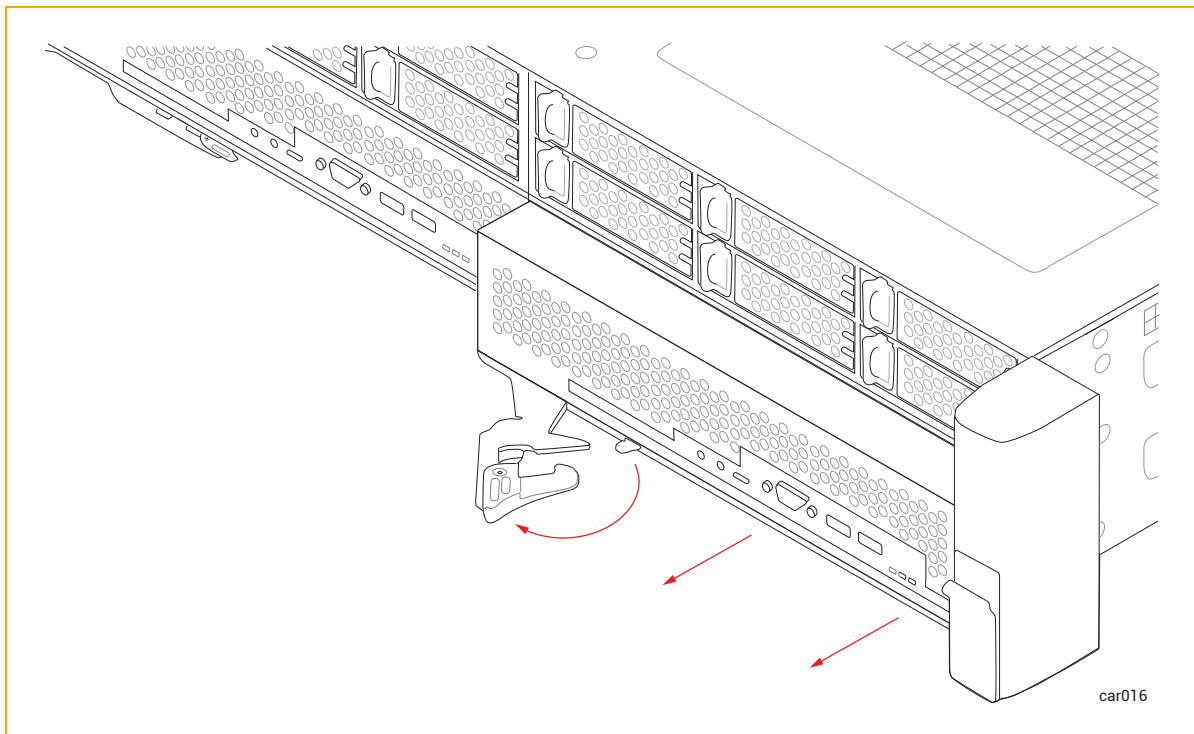

6. Holding the module on each side, pull it straight out of the system chassis and place it on a flat, stable surface.

To replace a compute module



Caution: Make sure that the left compute module is fully inserted and latched before you remove the right compute module. Otherwise, damage can result, and the right compute module cannot be removed.



Précaution: Assurez-vous que le module de calcul de gauche est complètement inséré et verrouillé avant de retirer le module de calcul de droite. Sinon, des dommages peuvent en résulter et le module de calcul de droite ne peut pas être retiré.

1. Check the "[Hardware Page](#)" on [page 233](#) of the ztC Endurance console to make sure that the compute module is in maintenance mode.
2. Extend the release lever on the compute module to the left until it is fully open.
3. Holding the compute module on each side, slide it into one of the bottom slots until it stops. Ensure that the module is fully seated and aligns with the system chassis.

4. Push on the center of the compute module with one hand while simultaneously using your other hand to push the release lever toward the system chassis until it clicks. See [Figure 5-2](#).

Figure 5-2: Replacing Compute Module

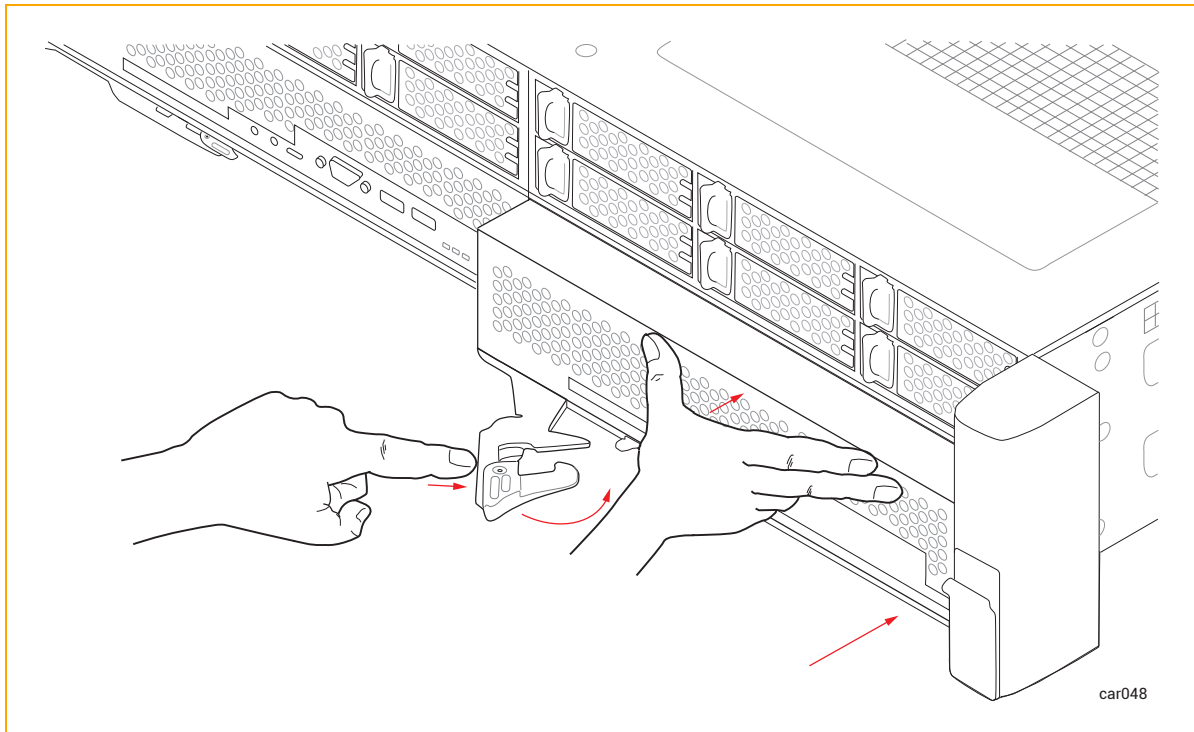

5. Push on the center of the compute module once more to make sure it is fully seated in the system chassis.
6. Connect all of the cables.
7. Remove the compute module from maintenance mode as described in ["Using Maintenance Mode"](#) on page 239.



Notice: If you insert a replacement compute module but do not remove it from maintenance mode, the system software cannot update the BMC, BIOS, or Standby OS. The system software also posts an alert to indicate that it cannot update the standby compute module until maintenance mode is cleared.

Related Topics

- ["Compute Module"](#) on page 21
- ["Memory in ztC Endurance Systems"](#) on page 22

Replacing, Adding, and Upgrading Memory

Replacing, adding, and upgrading ztC Endurance system memory involves removing and installing the DIMMs that are housed on ztC Endurance compute modules. Before working with DIMMs, read ["Memory in ztC Endurance Systems" on page 22](#).

This section describes:

- ["Terminology for Memory Procedures" on page 110](#)
- ["Important Cautions and Notes" on page 110](#)
- ["Replacing DIMMs" on page 111](#)
- ["Adding DIMMs" on page 113](#)

Terminology for Memory Procedures

Before adding memory to the ztC Endurance system or replacing existing DIMMs, review the following terms to understand how they are used in this guide:

- **Adding** – Increasing the quantity of DIMMS on the ztC Endurance system by inserting additional DIMMs in empty slots on the compute module.

When you add memory, you must add DIMMs to both compute modules. See ["Memory in ztC Endurance Systems" on page 22](#) for DIMM locations for your configuration.

- **Upgrading**– Increasing the total memory capacity of the ztC Endurance system by replacing an existing DIMM with a higher capacity DIMM (currently, the ztC Endurance system supports only 64GB DIMMs, but higher-capacity DIMMs may be supported in the future).
- **Replacing** – Removing an installed DIMM from a compute module and inserting a different DIMM in the same slot.
- **Removing** – Removing an existing DIMM from its slot on the ztC Endurance compute module.
- **Installing** – Inserting a DIMM in an empty slot on the ztC Endurance compute module.

Important Cautions and Notes

Cautions:



1. Use [ESD precautions](#) when performing these procedures.
2. Read ["Replacing System Components" on page 104](#) before you remove any system components.

Précautions:

1. Utilisez les précautions ESD lors de l'exécution de ces procédures.
2. Lisez "[Replacing System Components](#)" on page 104 avant de retirer des composants du système.



Note: Replacing DIMMs does not require a system shutdown, because you remove only one compute module at a time.



Notice: If you require assistance while adding DIMMs, your authorized Penguin Solutions service representative can provide onsite installation services for a fee.

Replacing DIMMs

To replace a DIMM on a ztC Endurance compute module, follow the instructions below and in the following section, "[Adding DIMMs](#)" on page 113.

To replace a DIMM

1. [Remove the compute module](#) that houses the DIMM you want to replace.
2. Place the compute module on a firm surface.
3. Using the information in "[Memory in ztC Endurance Systems](#)" on page 22, determine:
 - The slots in which DIMMs are currently installed
 - The correct slot in which to insert the new DIMM
4. Facing the front of the compute module:
 - If you are removing and replacing a DIMM on the left side of the compute module, remove the small baffle to the left of the DIMMs by gently pulling up one side of the baffle and then the other side. See [Figure 5-3](#).

Figure 5-4: Removing DIMM

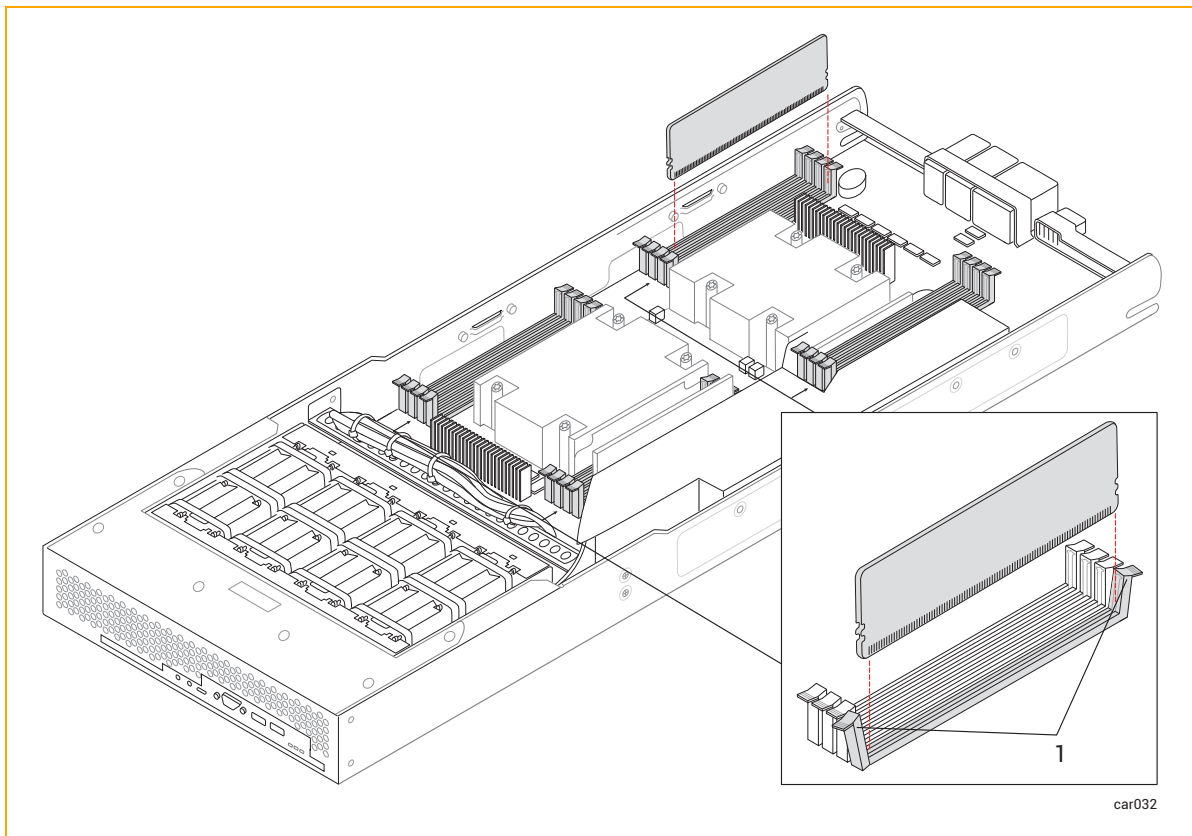

1 Ejector levers

6. Pull the DIMM straight up to remove it from the connector.

To install the new DIMM, proceed to the next section, ["Adding DIMMs" on page 113](#).

Adding DIMMs

You add a DIMM to a ztC Endurance compute module to increase the amount of system memory, or to replace an existing, faulty DIMM.

When you add memory, you must add DIMMs to both compute modules. See ["Memory in ztC Endurance Systems" on page 22](#) for DIMM locations for your configuration.

To insert a DIMM into a compute module

If you are inserting a DIMM in the same slot from which you just removed one, as described in the previous section, ["Replacing DIMMs" on page 111](#), proceed to Step 6 in the following procedure.

1. Perform a total shutdown of the ztC Endurance server using the **Shutdown** button on the ztC Endurance console **Dashboard** page.



Notice: Do not click the **Shutdown** button unless you are familiar with the topics discussed in "System Power" on page 84.

2. [Remove the compute module](#) that houses the DIMM you want to replace.
3. Place the compute module on a firm surface.
4. Using the information in "[Memory in ztC Endurance Systems](#)" on page 22, determine the correct slot in which to insert the new DIMM.
5. Facing the front of the compute module:
 - If you are adding a DIMM to the left side of the compute module, remove the small baffle to the left of the DIMMs by gently pulling up one side of the baffle and then the other side. See [Figure 5-3](#) in "[Replacing DIMMs](#)" on page 111.
 - If you are replacing a DIMM on the right side of the compute module, you do not need to remove the large baffle. Proceed to the next step.
6. Push down on the ejector levers at each end of the slot in which the DIMM will be inserted. See [Figure 5-4](#) in "[Replacing DIMMs](#)" on page 111.
7. With the DIMM connector ejector levers in the open position (down), align the small slots on the base of the DIMM with the notches at the base of the connector. The DIMMs product label must face the direction indicated by the arrows in [Figure 5-5](#).

Figure 5-5: Direction of DIMM Product Labels

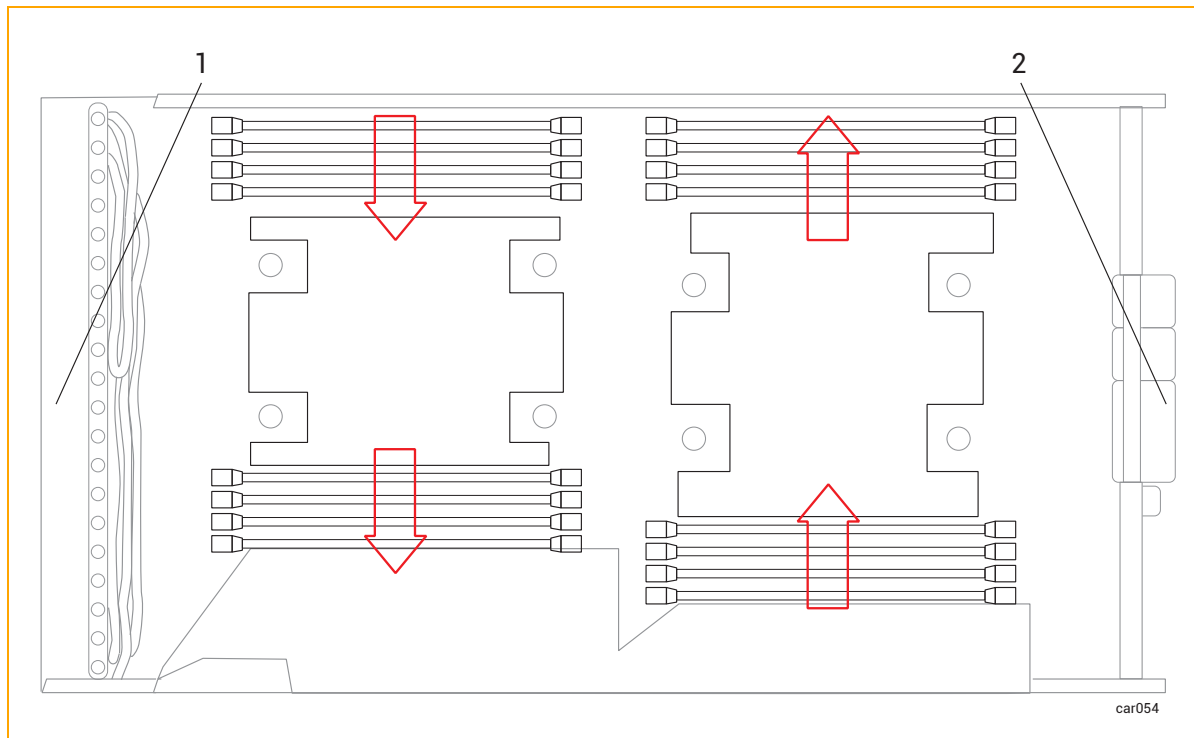

- | | |
|---|-------------------------|
| 1 | Front of compute module |
| 2 | Rear of compute module |

8. Push the DIMM down firmly into place. Make sure it is fully seated.



Caution: Ensure that the DIMM product label is facing the correct direction and the connector notches are properly aligned before seating the DIMM. Do not force.



Précaution: Assurez-vous que l'étiquette du produit DIMM est orientée dans la bonne direction et que les encoches du connecteur sont correctement alignées avant d'insérer le DIMM. Ne forcez pas.

9. Ensure that the connector's ejector levers are raised and fully locked into place. If they are not, eject and reseat the DIMM.
10. Optionally, repeat Steps 6 through 9 for any additional DIMMs.
11. If you removed the small baffle earlier, replace it by aligning the curved clips with the metal mounting pins on the side wall of the chassis. Push down firmly.

12. After installing the DIMMs, [replace the compute module](#).
13. Repeat this procedure from step 1 to add the required corresponding DIMM to the other compute module.
14. Power on the ztC Endurance system.
15. Watch the BIOS display for each compute module as it runs its Power-On Self-Test (POST) routine to ensure that the memory matches the expected configuration. Alternatively, when the system has booted to the operating system, you can use the ztC Endurance console to verify the memory configuration.

Related Topics

- ["Memory in ztC Endurance Systems" on page 22](#)
- ["Compute Module" on page 21](#)

Removing and Replacing a Storage Module

Cautions:



1. Use [ESD precautions](#) when performing these procedures.
2. Read ["Replacing System Components" on page 104](#) before you remove any system components.

Précautions:



1. Utilisez les précautions ESD lors de l'exécution de ces procédures.
2. Lisez ["Replacing System Components" on page 104](#) avant de retirer des composants du système.

To remove a storage module

1. Use your index finger to unlatch the release lever on the storage module.
2. Grasp the release lever and pull it away from the system chassis until the storage module extends an inch or two from the system chassis. See [Figure 5-6](#).

Figure 5-6: Removing Storage Module

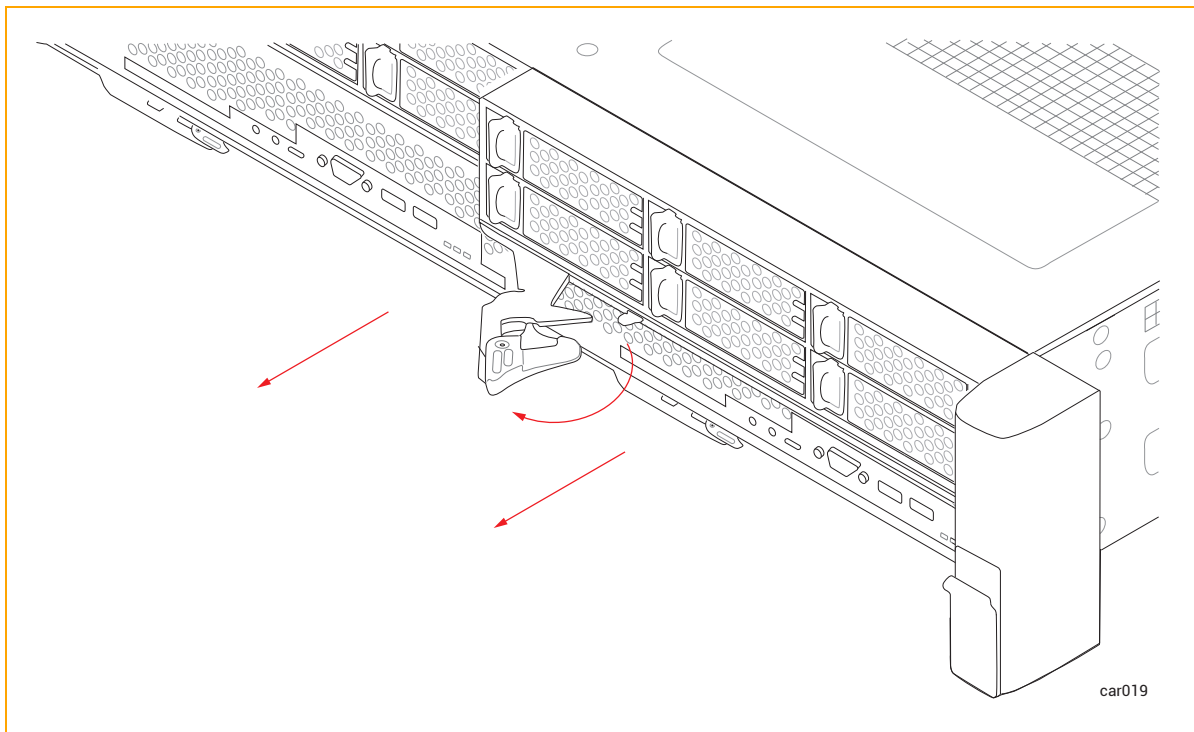

3. Holding the storage module on each side, pull it straight out of the system chassis and place it on a flat, stable surface.

To replace a storage module



Caution: Make sure that the left storage module is fully inserted and latched before you remove the right storage module. Otherwise, damage can result, and the right storage module cannot be removed.



Précaution: Assurez-vous que le module de stockage de gauche est complètement inséré et verrouillé avant de retirer le module de stockage de droite. Sinon, des dommages peuvent en résulter et le module de stockage droit ne peut pas être retiré.

1. Extend the release lever on the storage module to the left until it is fully open.
2. Holding the storage module on each side, slide it into one of the top slots until it stops. Ensure that the module is fully seated and aligns with the system chassis.
3. Push on the center of the storage module with one hand while simultaneously using your other hand to push the release lever toward the system chassis until it clicks. See [Figure 5-7](#).

Figure 5-7: Replacing Storage Module

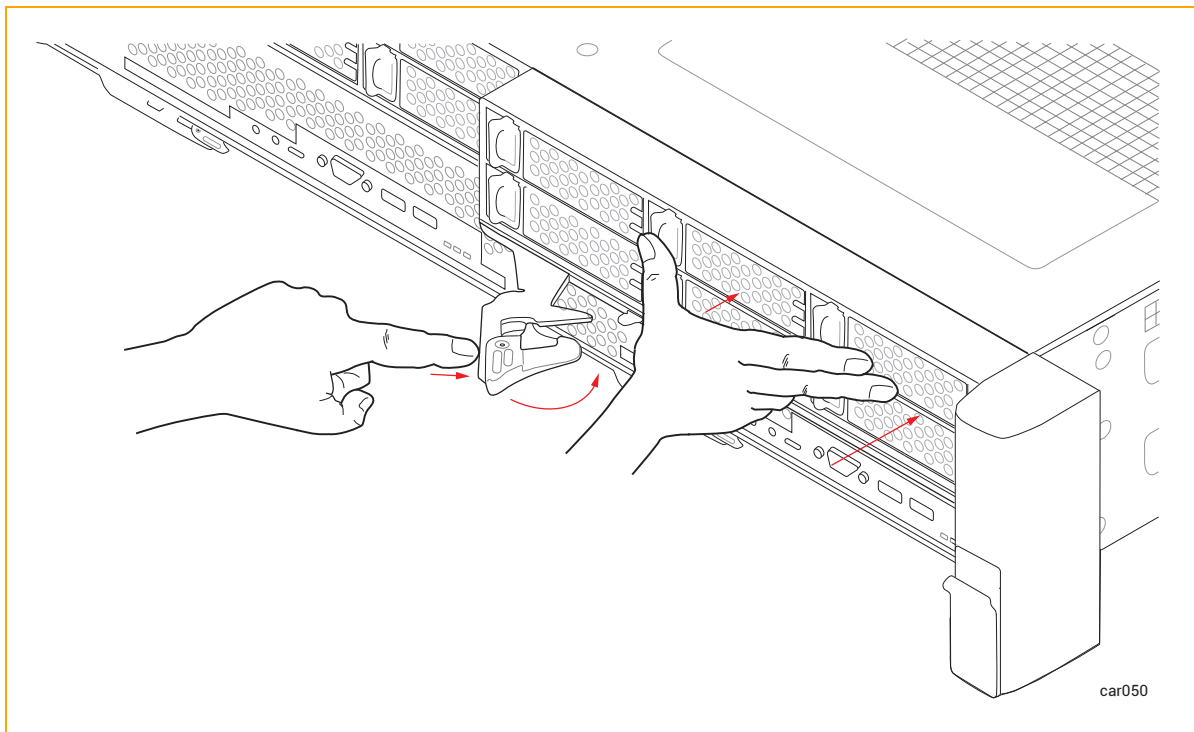

4. Push on the center of the storage module once more to make sure it is fully seated in the system chassis.

Related Topics

- ["Storage Module" on page 27](#)
- ["Removing and Inserting a Disk Drive" on page 118](#)

Removing and Inserting a Disk Drive

You can remove disk drives from a storage module to replace them or to perform other maintenance procedures. You do not need to power down or remove the storage module to perform this procedure.



Caution: Use [ESD precautions](#) when performing these procedures.



Précaution: Utilisez les précautions ESD lors de l'exécution de ces procédures.

To remove a disk drive

1. Slide the button on the release lever to the left until the release lever opens. See [Figure 5-8](#).

Figure 5-8: Removing Disk Drive

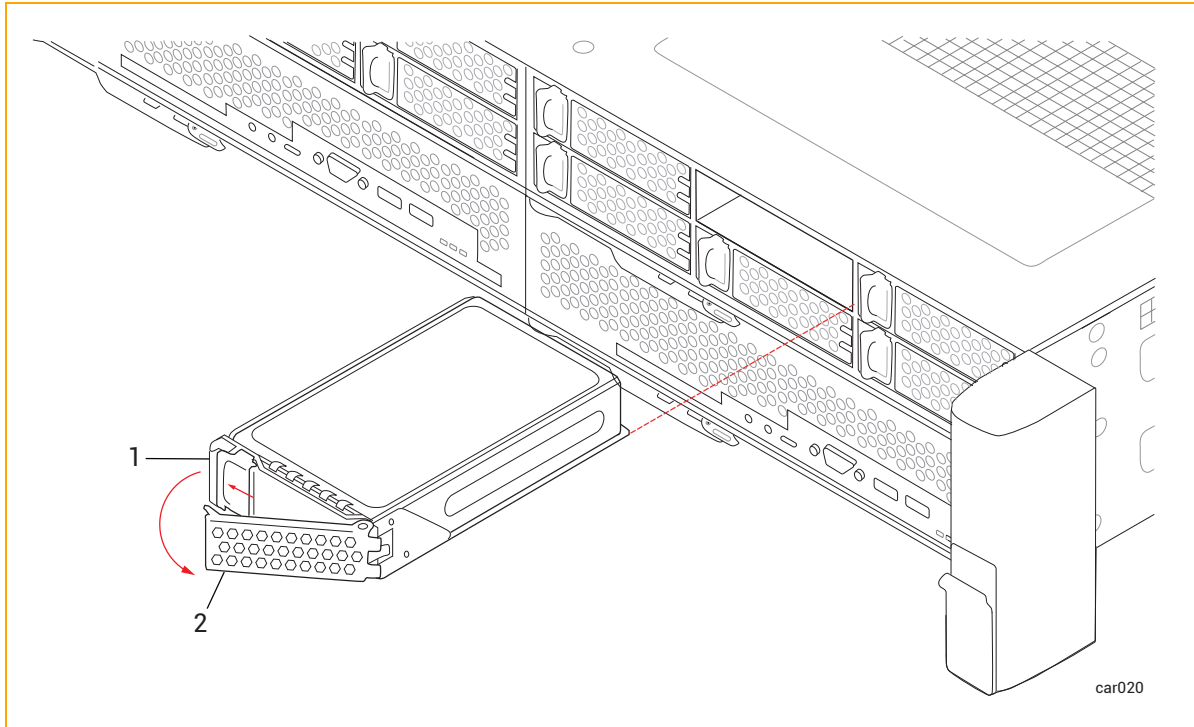

- | | |
|---|----------------|
| 1 | Release button |
| 2 | Release lever |

2. Pull the release lever and remove the disk drive.

To insert a disk drive



Note: You should be familiar with the information provided in "Disk Drives" on page 28 before you insert a disk drive.

1. With the release lever in the fully open position, insert the disk drive into the slot at the slight angle shown in [Figure 5-9](#). Stop when approximately three inches of the disk drive extend from the slot.

Figure 5-9: Inserting Disk Drive: Step 1

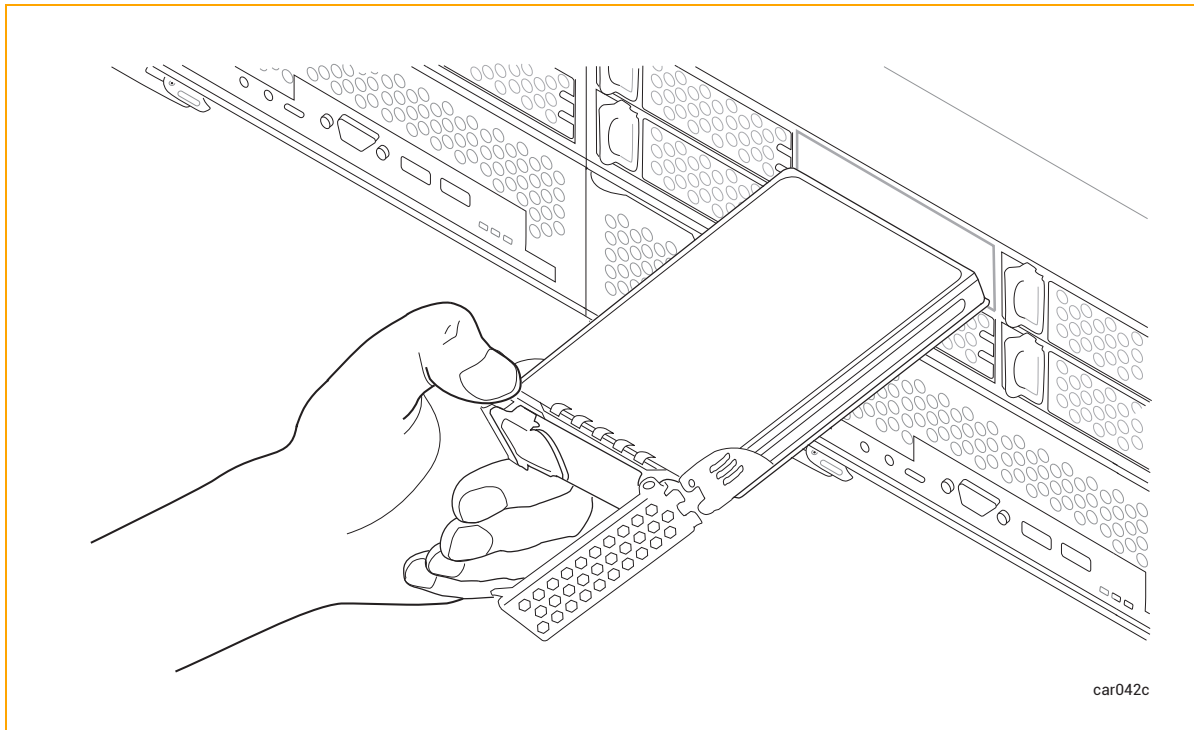

2. With the release lever still in the fully open position, use your left thumb to apply pressure on the release button while slowly inserting the disk drive into the slot. Stop when the two tabs on the right side of the release lever are flush with the slot opening. See [Figure 5-10](#).

Figure 5-10: Inserting Disk Drive: Step 2

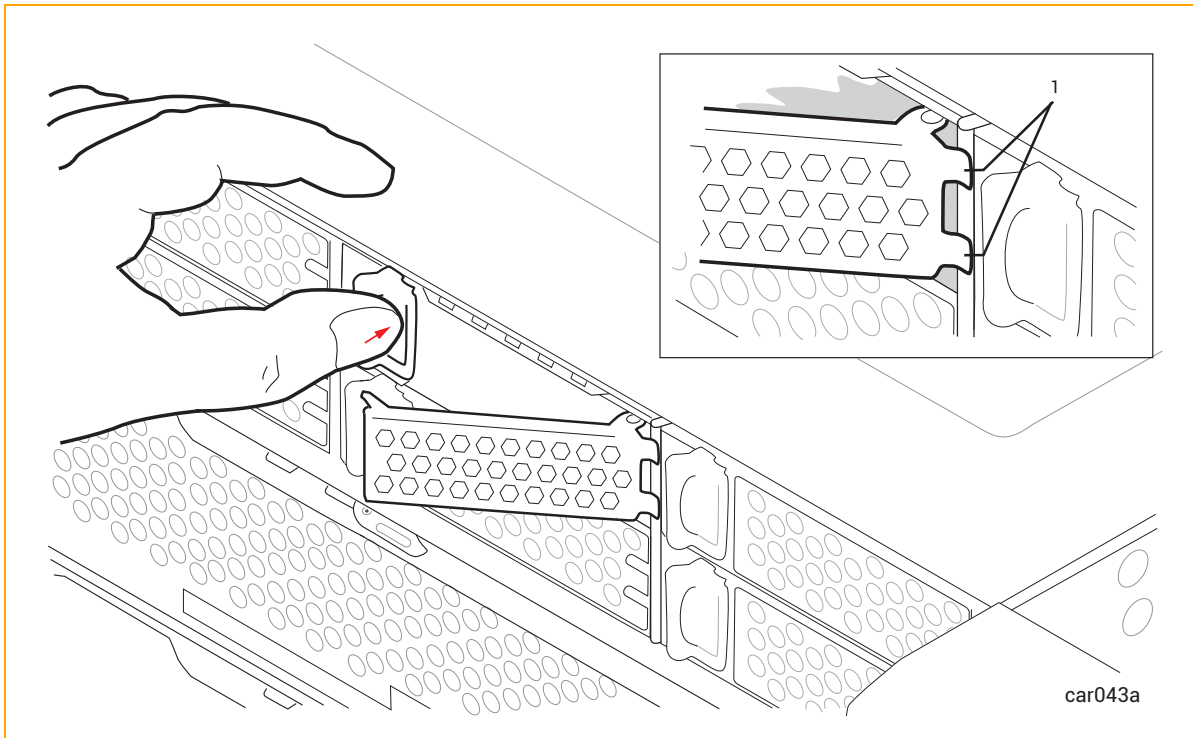

1 Tabs

3. While continuing to apply pressure to the release button with your left thumb, use your right thumb to push the release lever until it locks into place. See [Figure 5-11](#).

Figure 5-11: Inserting Disk Drive: Step 3

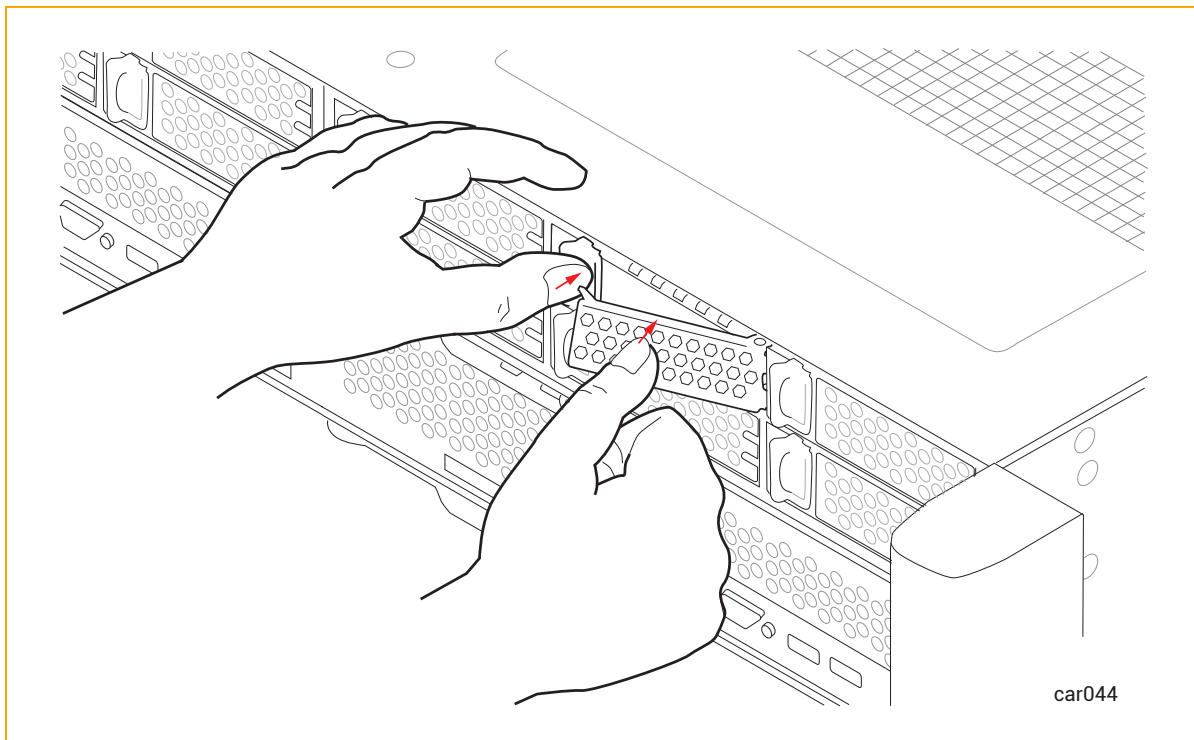

4. Push firmly again to make sure that the disk drive is fully seated. See [Figure 5-12](#).

Figure 5-12: Inserting Disk Drive: Step 4

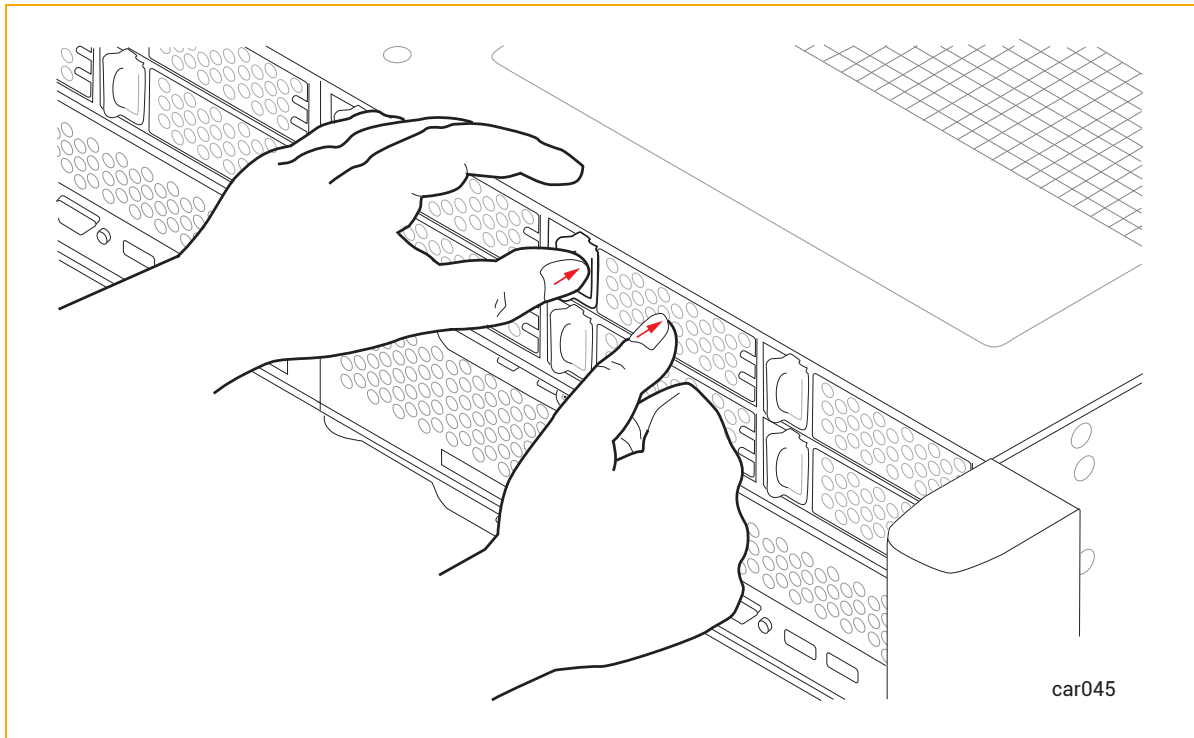

5. If the ztC Endurance system is powered on, check the disk drive's [ACT LED](#). If the LED is solid green, the disk drive is inserted correctly. If the LED is off, the disk drive is not inserted correctly; remove the disk drive and repeat this procedure.

Related Topics

- ["Disk Drives"](#) on page 28
- ["Internal Disk Drive Problems and Solutions"](#) on page 99
- ["Storage Module"](#) on page 27
- ["System Specifications"](#) on page 293

Removing and Replacing an I/O Module

Cautions:



1. Use [ESD precautions](#) when performing these procedures.
2. Read ["Replacing System Components"](#) on page 104 before you remove any system components.

Précautions:



1. Utilisez les précautions ESD lors de l'exécution de ces procédures.
2. Lisez "[Replacing System Components](#)" on page 104 avant de retirer des composants du système.

To remove an I/O module

1. Disconnect all cables from the I/O module.
2. Use your index finger to unlatch the release lever on the I/O module.
3. Grasp the release lever and pull it down until it is fully extended and the I/O module extends an inch or two from the system chassis. See [Figure 5-13](#).

Figure 5-13: Removing I/O Module

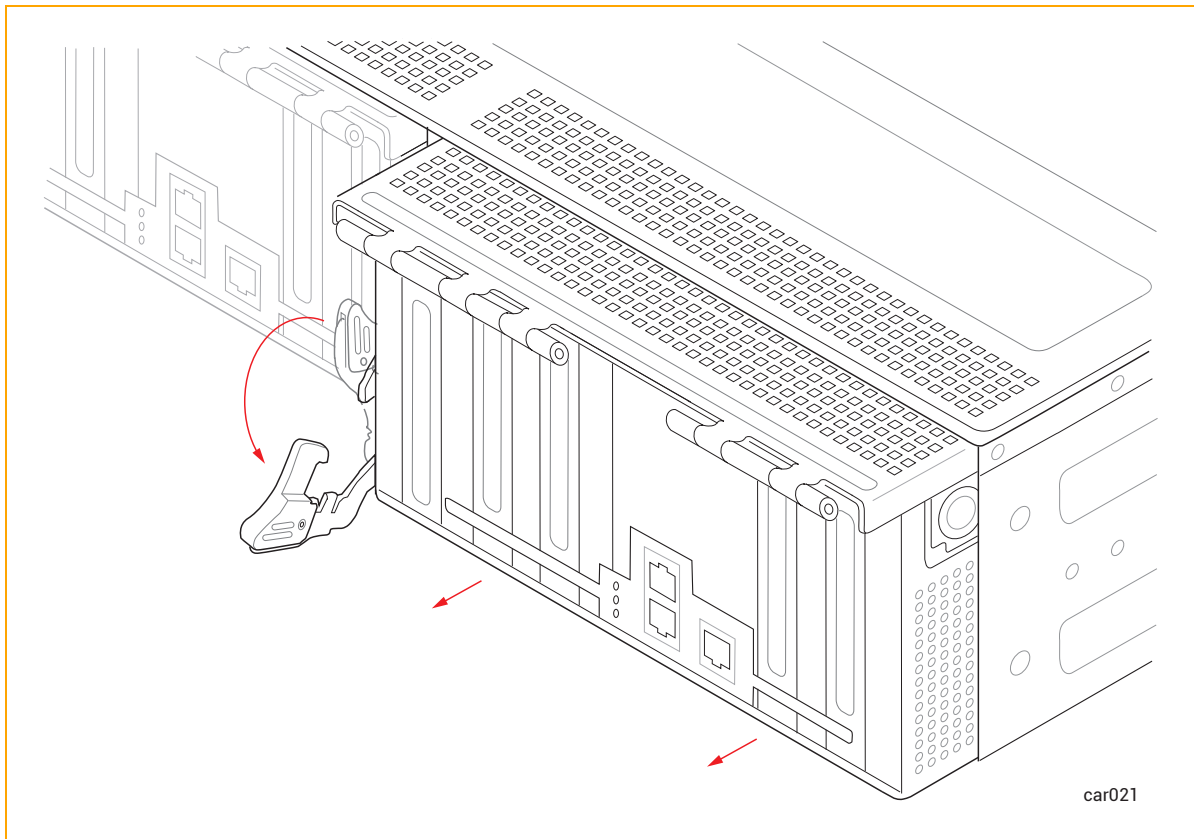

Caution: The release lever must be fully extended as shown in the figure before you perform step 4.



Précaution: Le levier de déverrouillage doit être complètement étendu comme indiqué sur la figure avant d'effectuer l'étape 4.

4. Holding the I/O module on each side, pull it straight out of the system chassis and place it on a flat, stable surface.

To replace an I/O module

1. Extend the release lever on the I/O module until it is fully open.
2. Slide the I/O module into the system chassis until it stops. Ensure that the module is fully seated and aligns with the system chassis.
3. Push on the center of the I/O module with one hand while simultaneously using your other hand to push up the release lever until it clicks. See [Figure 5-14](#).

Figure 5-14: Replacing I/O Module

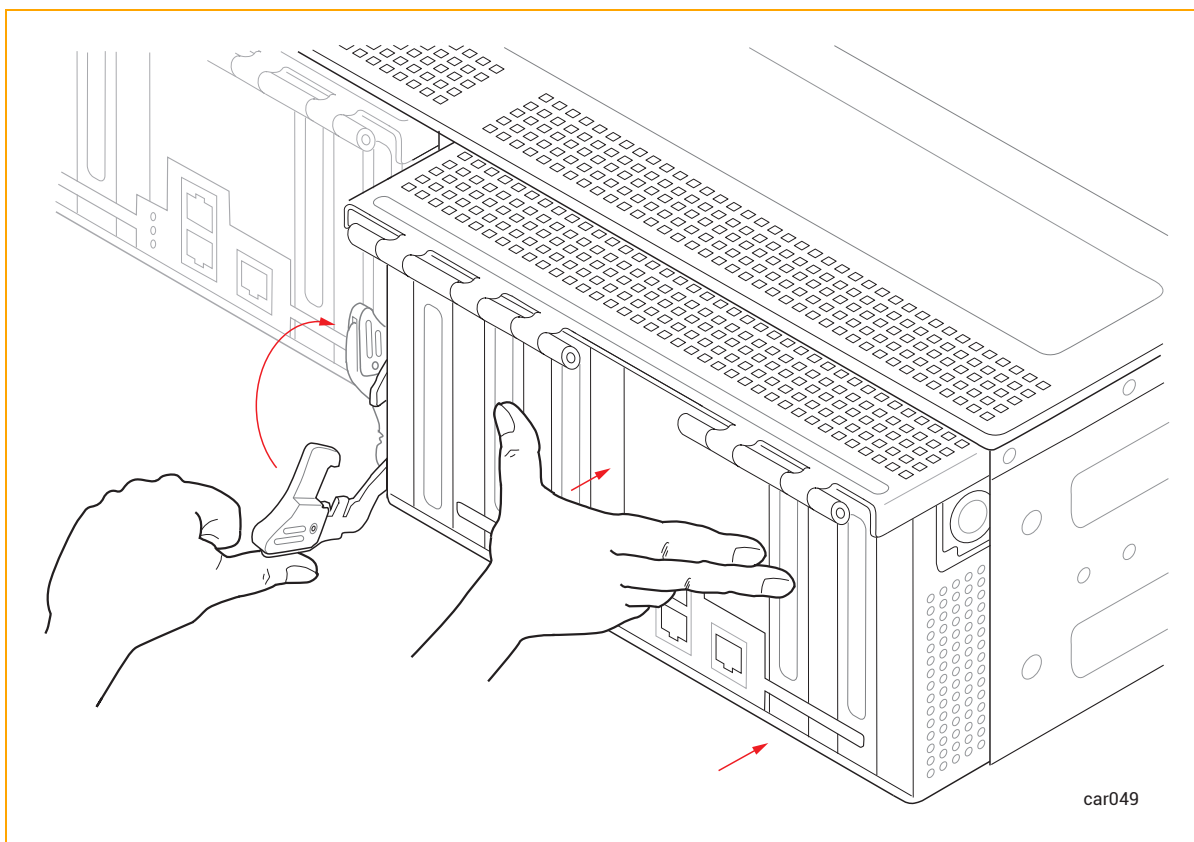

4. Push on the center of the I/O module once more to make sure it is fully seated in the system chassis.
5. Connect all of the cables.

Related Topics

- ["I/O Module" on page 30](#)
- ["Removing and Installing a PCIe Adapter" on page 126](#)
- ["PCIe Adapters" on page 31](#)

Removing and Installing a PCIe Adapter

Cautions:



1. Use [ESD precautions](#) when performing these procedures.
2. Read ["Replacing System Components" on page 104](#) before you remove any system components.

Précautions:



1. Utilisez les précautions ESD lors de l'exécution de ces procédures.
2. Lisez ["Replacing System Components" on page 104](#) avant de retirer des composants du système.

Notes:



1. You do not need to shut down a ztC Endurance system when you remove or install PCIe adapters. You simply remove one I/O module, remove/install PCIe adapter(s), and reinstall the I/O module. Repeat this procedure for the other I/O module.
2. Supported PCIe adapters that contain small form-factor pluggable (SFP) modules take up the length of an entire PCIe slot. To more easily remove or install these longer adapters, first remove the SFP modules as noted in the following procedures.

To remove a PCIe adapter

Notices:



1. When handling PCIe adapters, hold them securely by their edges. Do not touch their electronic elements.
2. Always store a PCIe adapter in its static-protective envelope if it is not installed in the system.

1. [Remove the I/O module.](#)
2. Disengage the metal cage by pushing the buttons on each side of the I/O module, and then flip the metal cage open. See [Figure 5-15](#).

Figure 5-15: Opening Metal Cage

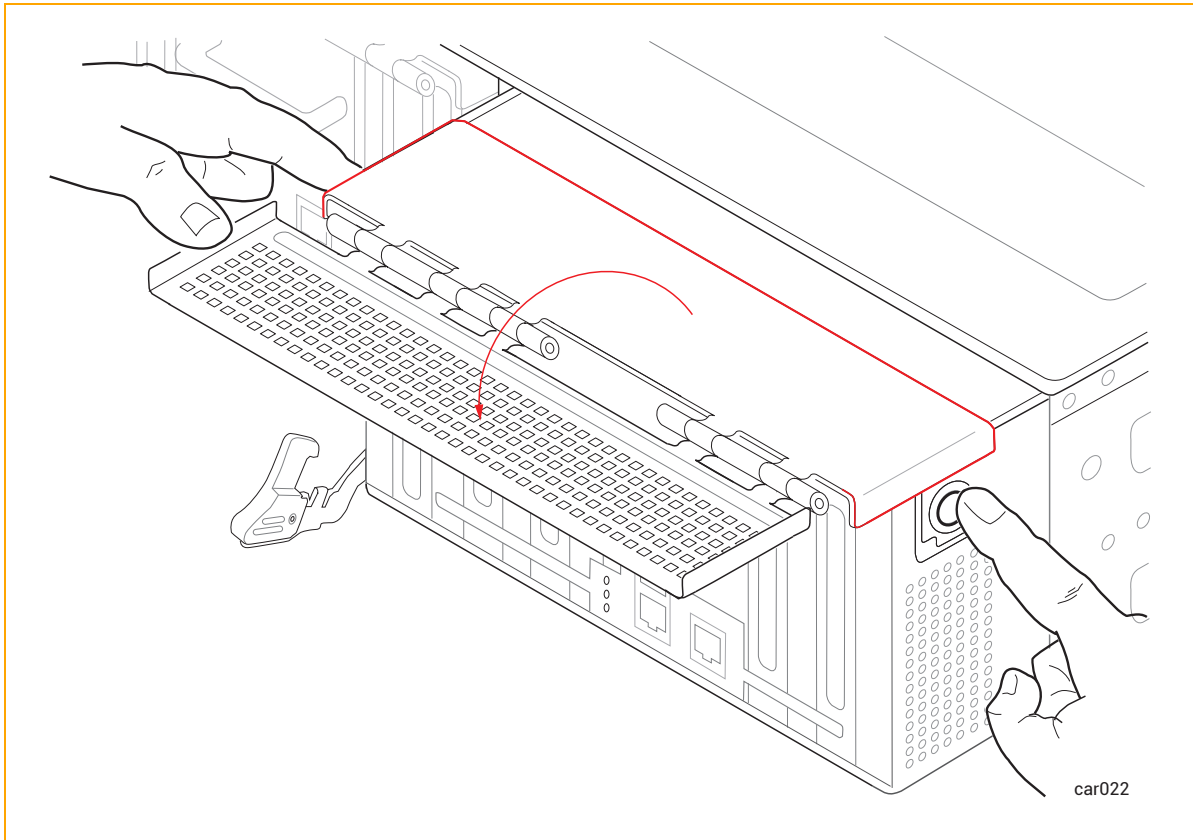

3. If your PCIe adapter contains SFP modules, remove them and go to the next step.
Otherwise, go to the next step.
4. Pull the PCIe adapter out of its connector. See [Figure 5-16](#).

Figure 5-16: Removing PCIe Adapter

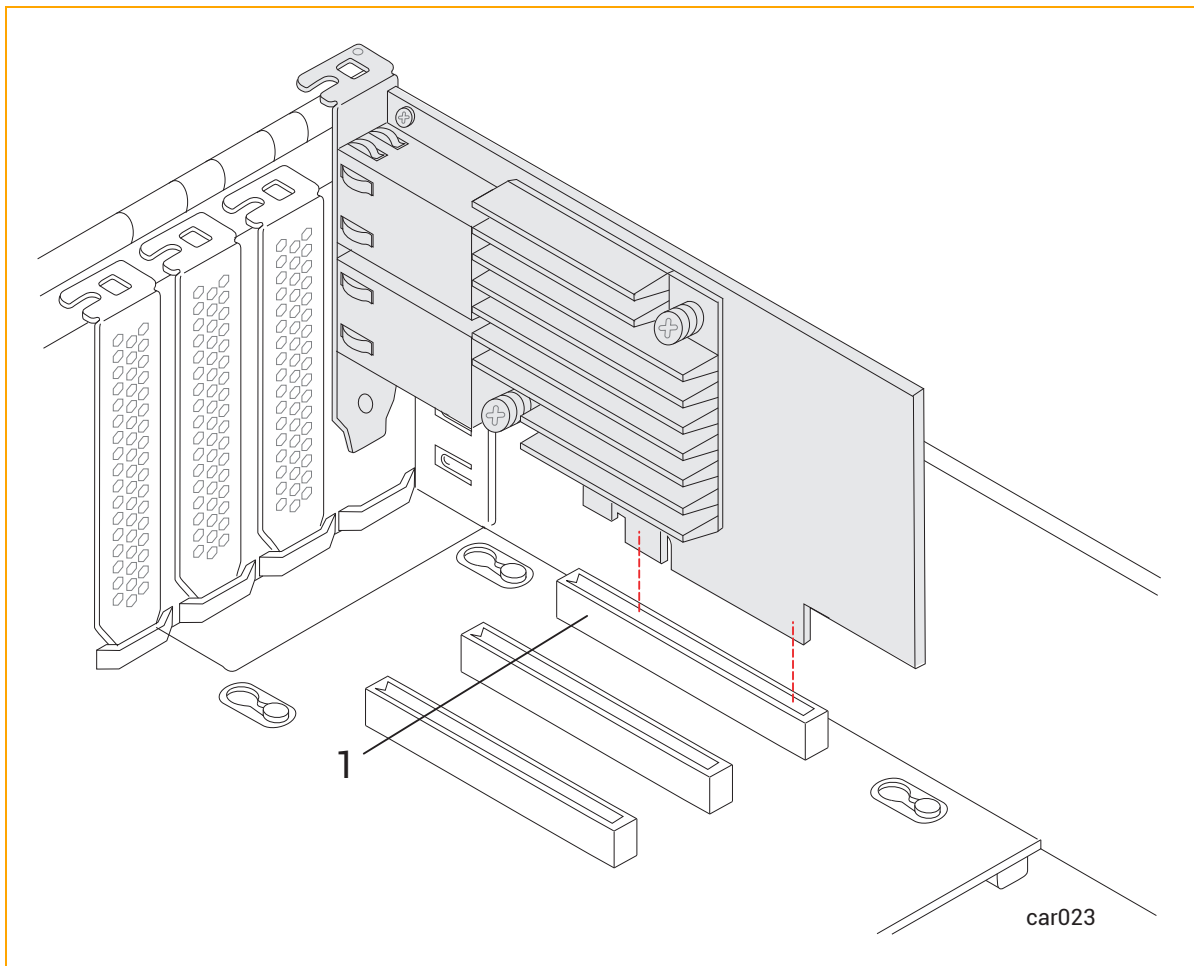

1 Connector

5. If the adapter does not disconnect easily, use a firm side-to-side tugging motion while maintaining steady pressure on the adapter.

To install a PCIe adapter



Note: You should be familiar with the important information provided in "PCIe Adapters" on page 31 before you install a PCIe adapter.



Notice: Before you begin this procedure, move the I/O module so that its front overhangs the surface on which it is resting by approximately two inches. Otherwise, the PCIe adapter cannot be installed correctly.

Figure 5-18: Closing Metal Cage

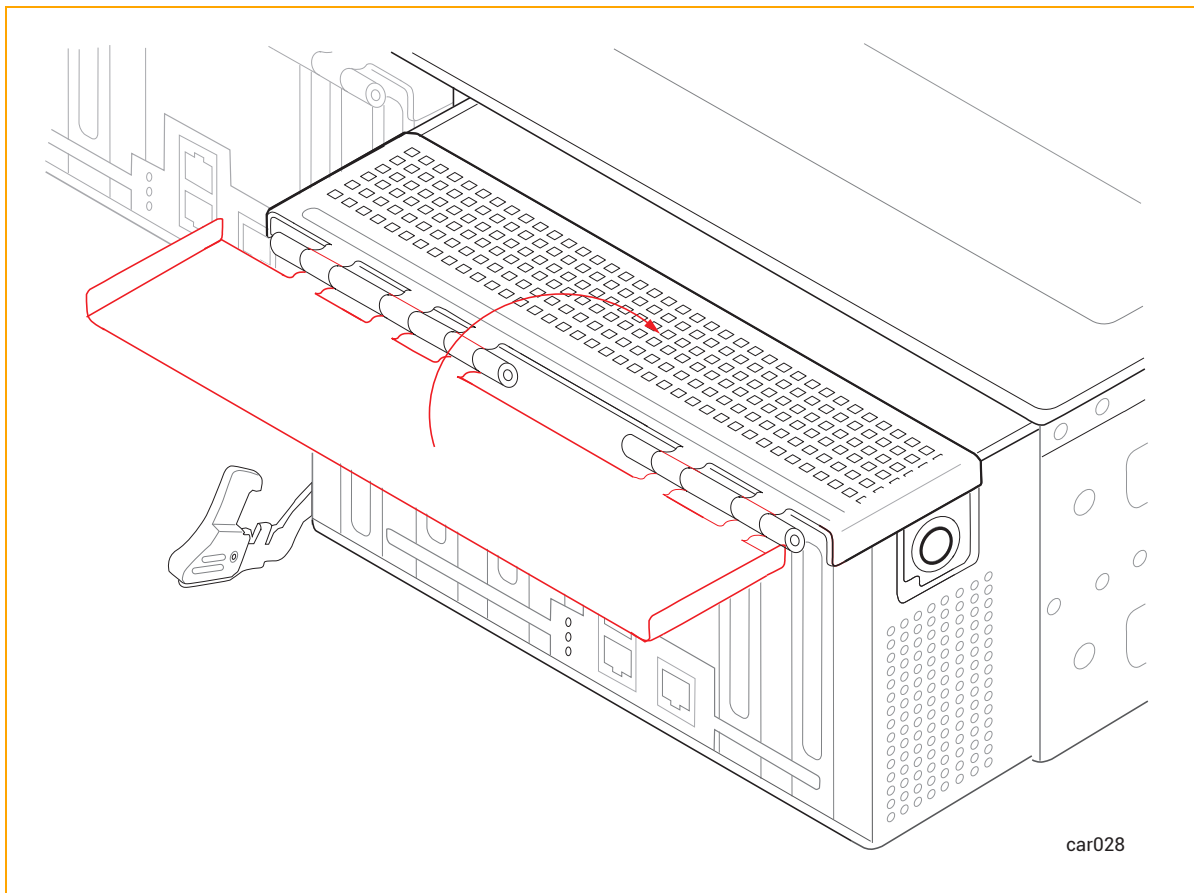

5. [Replace the I/O module.](#)

Related Topics

- "PCIe Adapters" on page 31
- "I/O Module" on page 30

Removing and Replacing a PSU and Power Cords

Cautions:



1. Use [ESD precautions](#) when performing these procedures.
2. Read "Replacing System Components" on page 104 before you remove any system components.

Précautions:



1. Utilisez les précautions ESD lors de l'exécution de ces procédures.
2. Lisez "[Replacing System Components](#)" on page 104 avant de retirer des composants du système.

To remove a PSU

1. Unwrap the power-cord retention strap, and then disconnect the power cord. See [Figure 5-19](#).

Figure 5-19: Disconnecting Power Cord and Retention Strap

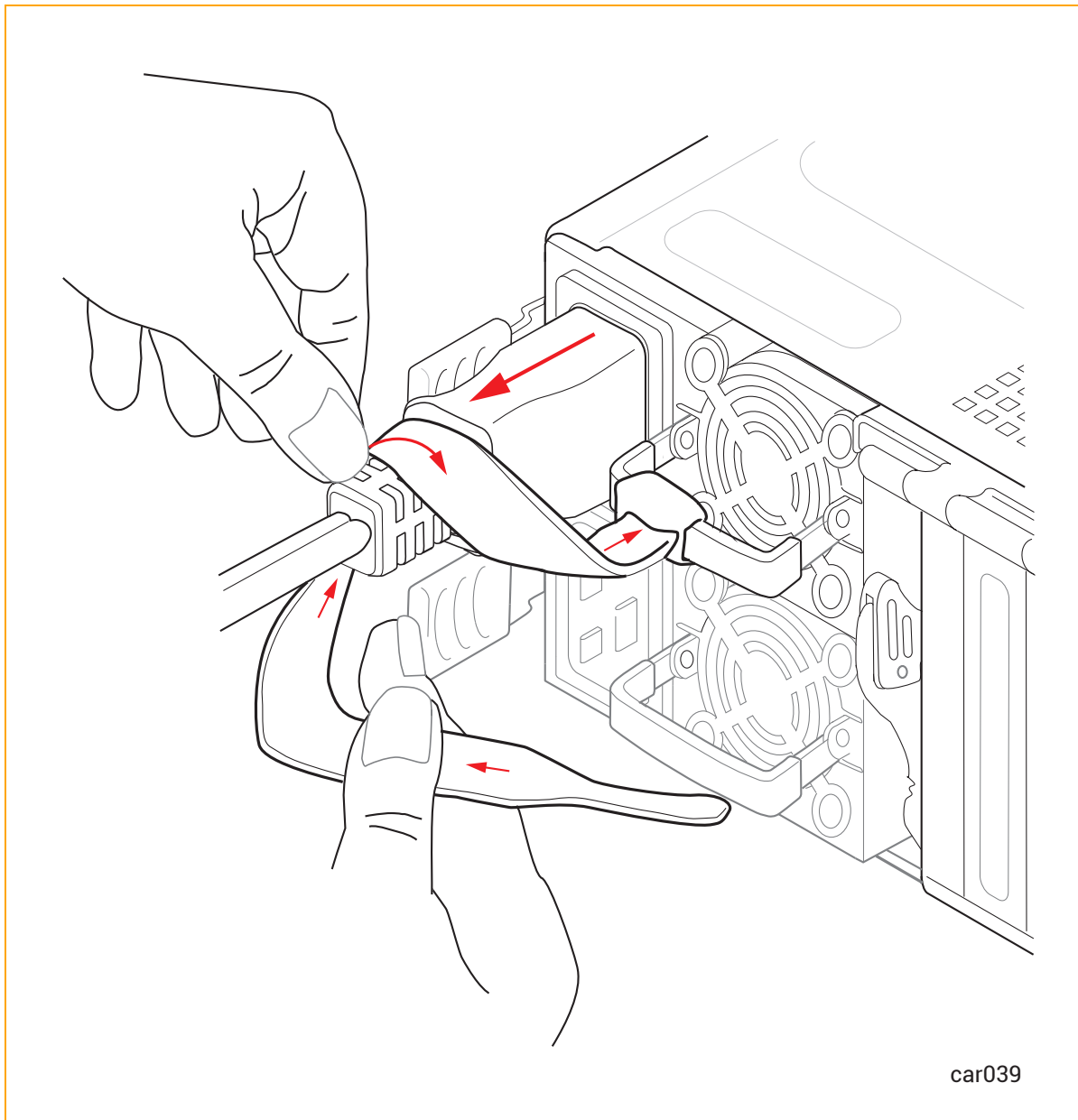

2. Push the release lever to the right while pulling the handle until the PSU releases. See [Figure 5-20](#).

Figure 5-20: Pushing PSU Release Lever

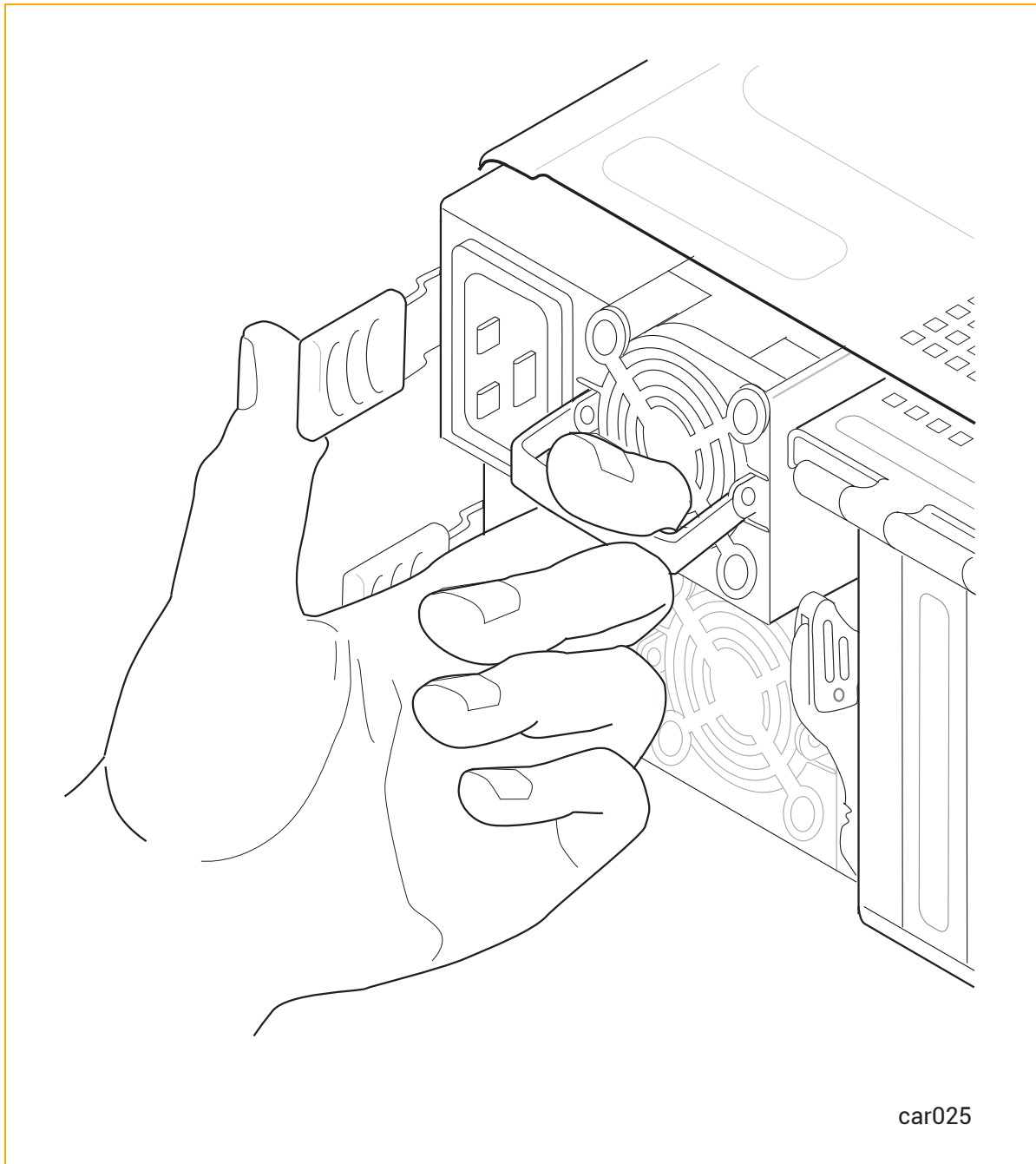

3. Release the release lever and pull the PSU out of the system chassis.

To replace a PSU



Caution: When you insert a PSU into the system chassis, make sure that the plug is on the left and the fan is on the right, as shown in [Figure 5-19](#). Otherwise, damage may result.



Précaution: Lorsque vous insérez un bloc d'alimentation dans le châssis du système, assurez-vous que la fiche est à gauche et que le ventilateur est à droite, comme indiqué sur [Figure 5-19](#). Sinon, des dommages pourraient en résulter.

1. Slide the PSU into the system chassis until it stops.
2. If necessary, push the release lever to the right and gently push the PSU in until it is fully seated and the release lever latches.
3. Connect the power cord, and perform the steps in "[To fasten the power-cord retention strap](#)" on [page 77](#).

To replace both power cords

1. Power off the system as described in "[Shutting Down the System](#)" on [page 86](#).
2. Disconnect all communications cables from the system.
3. Unwrap the power-cord retention straps, and then disconnect the power cords from the PSUs and the power sources.
4. Wait for all LEDs in the [front](#) and [rear](#) of the system to turn off, including the LEDs on both PSUs. All LEDs turning off indicates that the standby voltages have dissipated.
5. Replace the two power cords, using the correct power cords for the voltage being used, and [fasten the power-cord retention straps](#).
6. Reconnect all communications cables to the system.

6

Chapter 6: Electrical Circuit and Wiring Information

For electrical circuit and wiring information that you need to provide to the contractor and/or facilities personnel responsible for wiring the power at the system installation site, see:

- ["Fault Protection Requirements" on page 135](#)
- ["Grounding Considerations" on page 135](#)
- ["Circuit Wiring Diagrams" on page 136](#)
- ["Electrical Power Connectors" on page 142](#)

Fault Protection Requirements

Each CRU module in a ztC Endurance system contains internal fault/overload current protection. However, the system relies on the power distribution system at your site for protection against potential faults in the power cords and the wiring in the PSU AC inlet.

Power cords for a ztC Endurance system and PDU must not be connected to a branch circuit greater than 20A.

Related Topics

- ["Electrical Circuit and Wiring Information" on page 135](#)

Grounding Considerations

The system obtains an earth reference ground through the power cords attached to the system. Similarly, each peripheral device connected to the system obtains ground through its power cord. You **must** ensure that a high-integrity safety-ground conductor is installed as part of the wiring system (in accordance with U.S. national electric code NFPA 70 or the equivalent). The international safety standard (EN62368) for audio/video, information, and communication technology equipment also requires a ground conductor, but calls it a protective earth (PE) ground.

Depending on local conditions, ground potentials may differ between the system base and any peripheral devices connected to the system base. All grounds in the system **must** return to the same reference point in the power distribution system, as close as possible to **zero (0) volt potential** relative to earth reference ground. Earth reference ground is typically a metal stake in the ground to which the ground conductors from one or more buildings are attached.

As shown in [Figure 6-1](#), a *star ground* is often used to obtain the same earth reference ground. Each earth reference ground, such as the system base ground, is returned separately to a common point where a zero-volt (0V) earth ground exists. The star ground ensures that all equipment is at the same potential and that no noise or safety problems associated with an unpredictable or uncharacterized grounding system will occur.

Figure 6-1: Star Ground Example

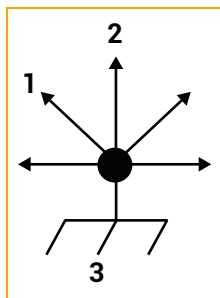

- | | |
|---|-----------------------------|
| 1 | To monitor |
| 2 | To ztC Endurance system |
| 3 | Earth reference ground (0V) |

Related Topics

- ["Electrical Circuit and Wiring Information" on page 135](#)

Circuit Wiring Diagrams

The circuit wiring diagrams shown in this topic illustrate how the hot, ground, and/or neutral AC signals should be connected to the power input plugs of the ztC Endurance system and other components.

In the following diagrams, the power inputs for ztC Endurance systems are labeled X and Y, as shown in [Figure 6-2](#) and [Figure 6-3](#), to eliminate any ambiguities in the nomenclature. For single-phase applications, the X input is connected to the L (Line) hot input, and the Y input is connected to the N (Neutral) input. However, for split-phase or three-phase applications, the X and Y inputs are connected to L1, L2, or L3 (separate lines). Therefore, for split-phase or three-phase applications, both X and Y can be electrically hot with respect to the system base (earth reference ground).

Figure 6-2 shows a face view of the physical locations of the X and Y inputs on a customer-supplied PDU (either A or B).

Figure 6-2: PDU Power Input Labeling

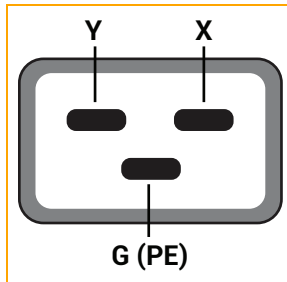

Figure 6-3 shows a face view of the physical locations of the X and Y inputs on a ztC Endurance system's PSU (either A or B).

Figure 6-3: ztC Endurance Enclosure Power Input Labeling

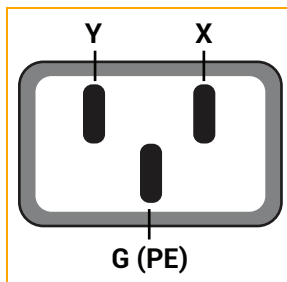

Figure 6-4 shows a single-phase 120V AC circuit connection. Note that this application requires a single-pole circuit breaker.

Figure 6-4: Single-Phase 120V AC Circuit Connection

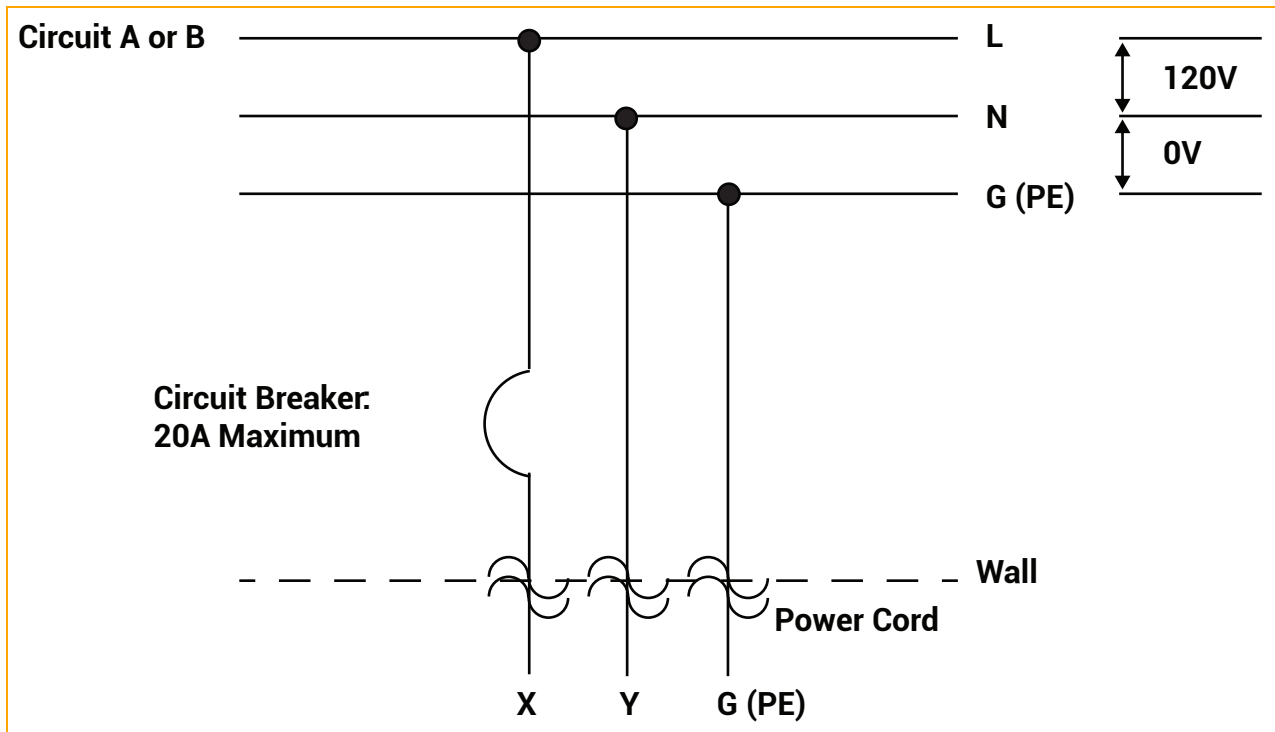

Figure 6-5 shows a single-phase 240V AC circuit connection. Note that this application requires a single-pole circuit breaker.

Figure 6-5: Single-Phase 240V AC Circuit Connection

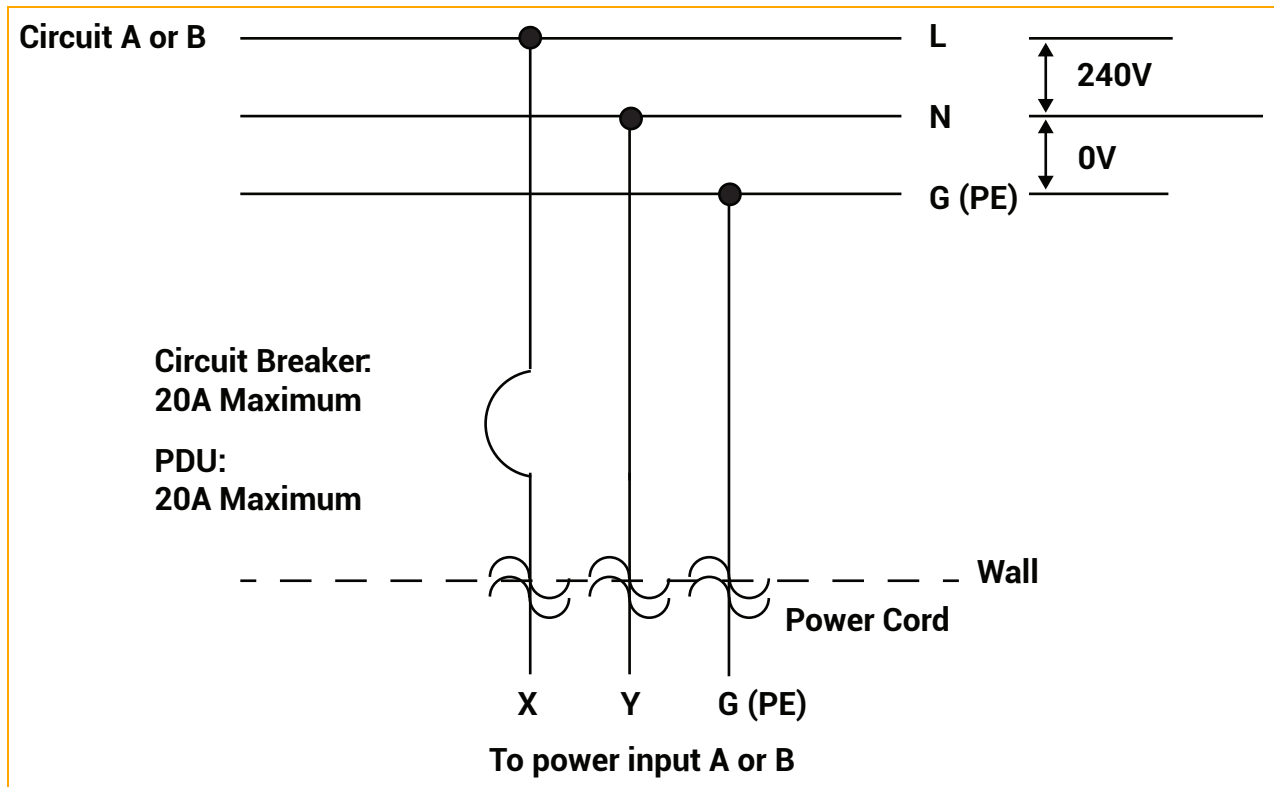

Figure 6-6 shows a split-phase 120/240V AC circuit connection. Note that this application requires a double-pole circuit breaker.

Figure 6-6: Split-Phase 120/240 Volts AC Circuit Connection

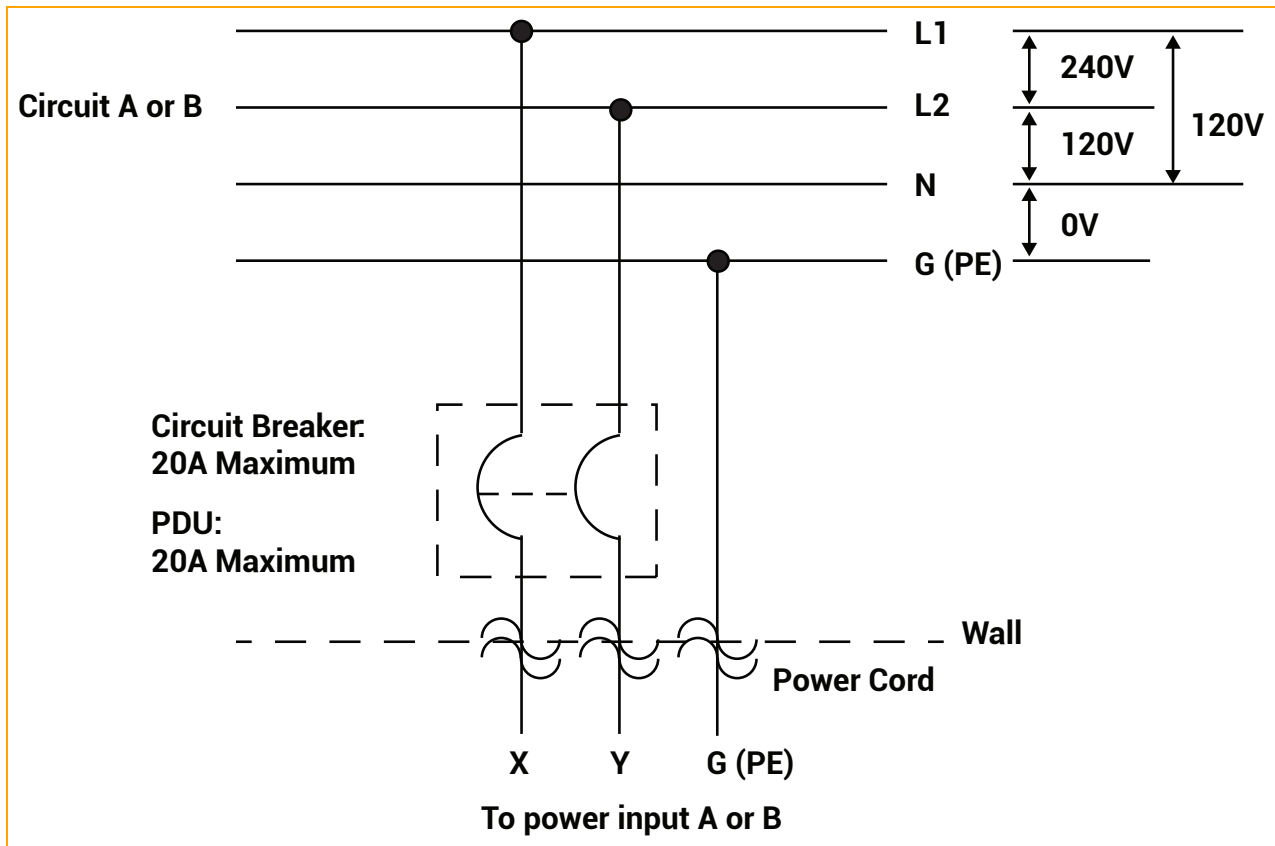

Figure 6-7 shows a three-phase 208V AC, Y-, or Δ -source circuit connection, which is a phase-to-phase source connection. Note that the X and Y inputs on the ztC Endurance system can be connected from L1 and L2, L2 and L3, or L1 and L3. This application requires a double-pole circuit breaker.

Figure 6-7: Three-Phase 208V AC, Y-, or Δ -Source Circuit Connection, Phase-to-Phase

Figure 6-8 shows a three-phase 380V AC, Y-, or Δ -source circuit connection, which is a phase-to-neutral source connection. Note that the ztC Endurance system's X input can be connected to L1, L2, or L3. This application requires a single-pole circuit breaker.

Figure 6-8: Three-Phase 380V AC, Y-, or Δ-Source Circuit Connection, Phase-to-Neutral

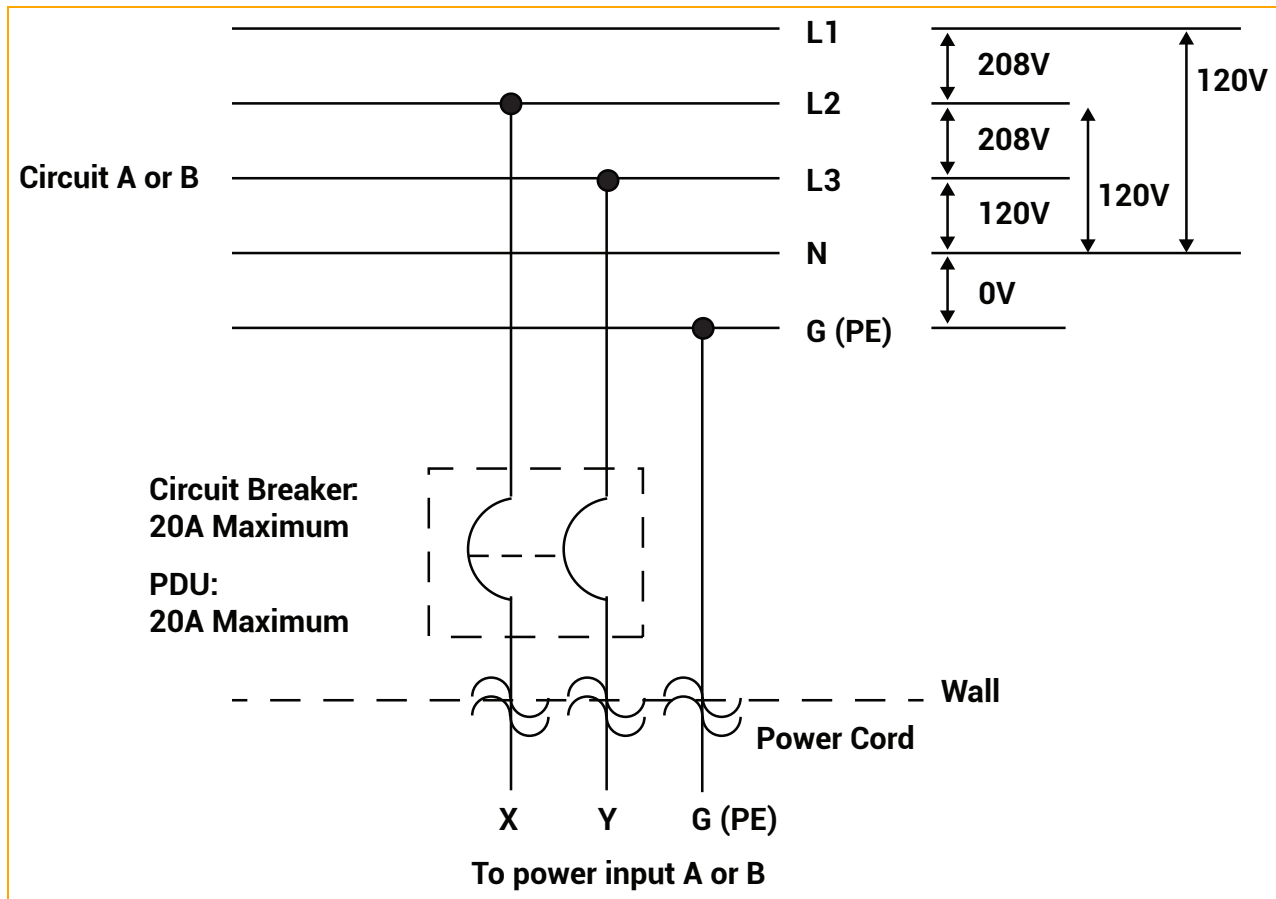
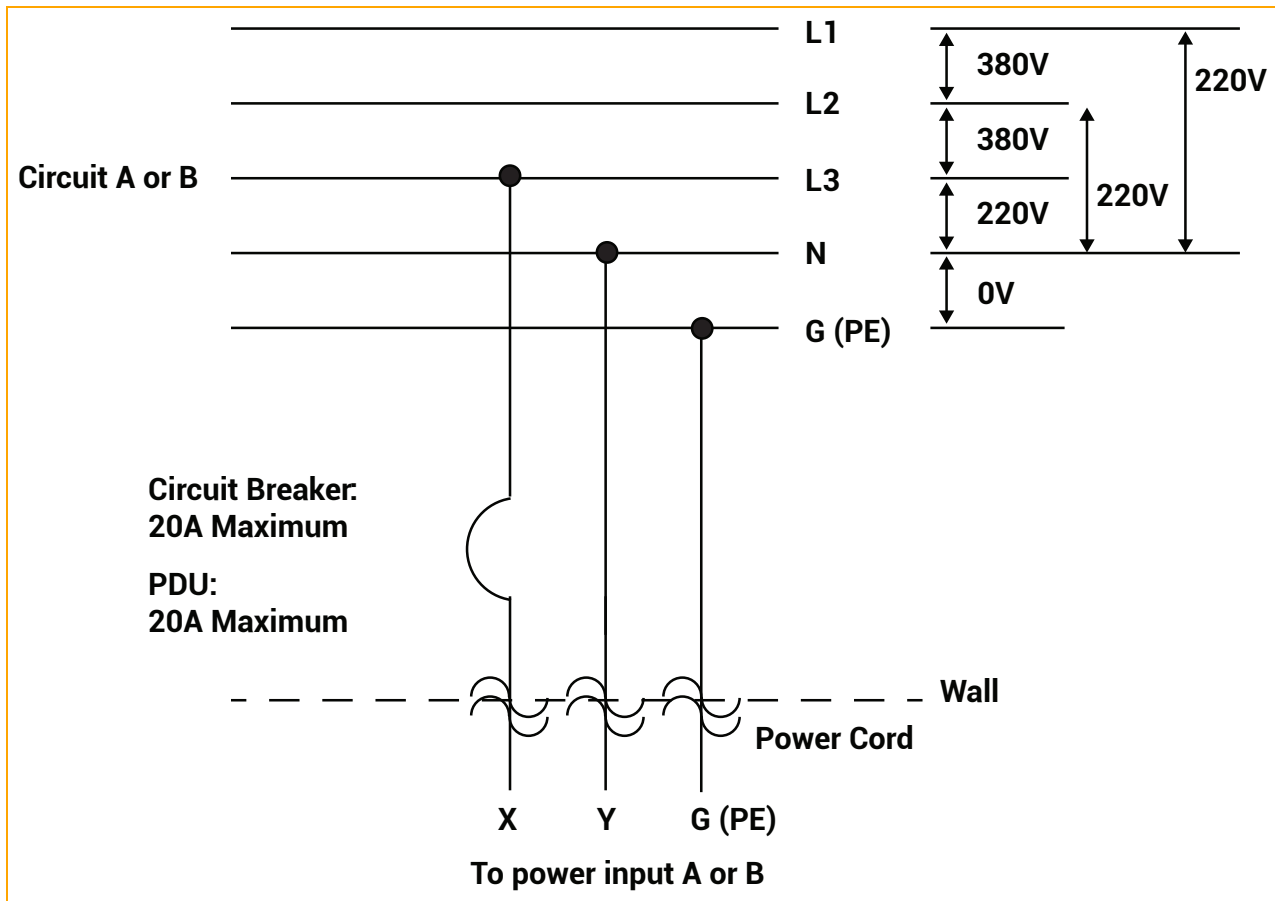

Related Topics

- ["Electrical Circuit and Wiring Information" on page 135](#)

Electrical Power Connectors

Table 6-1 describes the connectors (that is, the receptacles) required by the AC power cords that Penguin Solutions supplies with ztC Endurance systems and optional devices.

Table 6-1: Connectors for AC Power Outlets

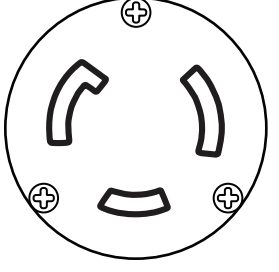
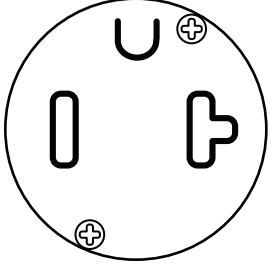
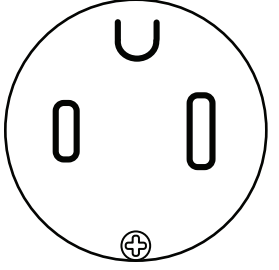
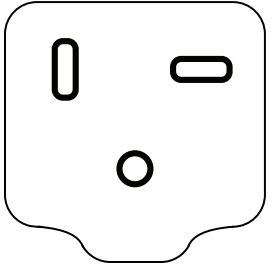
Connector	Configuration	Rating	Description
NEMA L6-20		20A, 250 volts AC	2-pole, 3-wire
NEMA 5-20		20A, 125 volts AC	2-pole, 3-wire
JIS C 8303		15A, 125 volts AC	2-pole, 3-wire
JIS C 8303		15A, 250 volts AC	2-pole, 3-wire

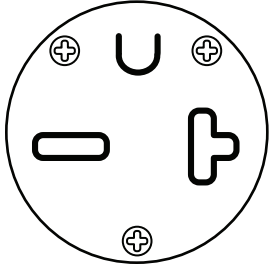
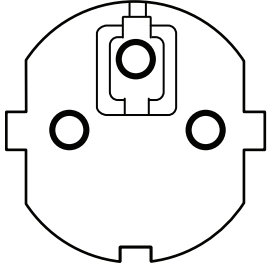
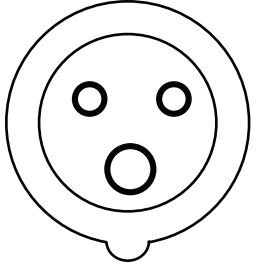
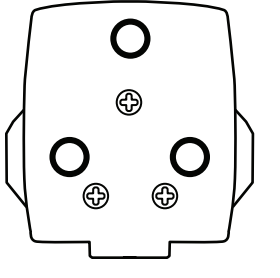
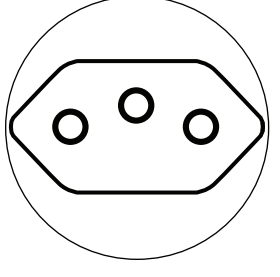
Connector	Configuration	Rating	Description
NEMA 6-20 / CNS 690		20A, 250 volts AC	2-pole, 3-wire
CEE (7) VII		16A, 250 volts AC	2-pole, 3-wire
IEC 60309 (formerly IEC 309)		16-20A, 250 volts AC	2-pole, 3-wire
SABS 164-1:1992 / IS 1293 IND 16		16A, 250 volts AC	2-pole, 3-wire
NBR 14136 (Brazil)		10A, 250 volts AC	2-pole, 3-wire

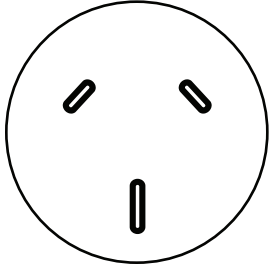
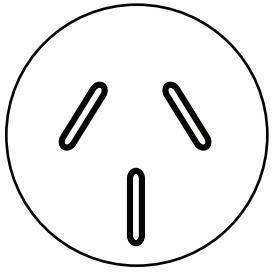
Connector	Configuration	Rating	Description
SAA/3/15 AS/NZS 3112-1993		15A, 250 volts AC	2-pole, 3-wire
GB1002-1996		10A, 250 volts AC	2-pole, 3-wire

Related Topics

- ["Electrical Circuit and Wiring Information" on page 135](#)

Part 2: ztC Endurance Software Guide

The ztC Endurance Software Guide discusses the following topics:

- ["System Software Installation and Upgrade \(VMware\)" on page 149](#)
- ["System Software Administration \(VMware\)" on page 209](#)
- ["Using the ztC Endurance Console" on page 223](#)
- ["Overview of the BMC Web Console" on page 277](#)

Related Topics

- ["ztC Endurance Hardware Guide" on page 15](#)
- ["ztC Endurance Supporting Documents" on page 283](#)

7

Chapter 7: System Software Installation and Upgrade (VMware)

To install the system software, see ["Installing the System Software" on page 149](#).

To upgrade the system software, see ["Upgrading the System Software" on page 191](#).

Installing the System Software

Before you install the system software, you power on the system to boot the Standby OS on both compute modules, and you later run configuration scripts to enter different settings that are required to support the software installation.



Note: On all ztC Endurance systems, the Standby OS (Ubuntu, a Linux distribution) is preinstalled at the factory in an internal NVMe drive inside each compute module. In general, you need to access the Standby OS only for system software installation or troubleshooting purposes.

After the software installation completes, you need to perform some post-installation tasks, as described in ["Post-Installation Tasks" on page 185](#).

Next Steps

Prepare for the system software installation as described in ["Preparing to Install the System Software" on page 149](#).

Preparing to Install the System Software

Review the preinstallation checklist before you install the system software.



Caution: Make sure that the network switch used during the system software installation is 1 Gb or faster. Otherwise, the copy of the system software ISO to the host system may time out, resulting in a failed installation.

Preinstallation Checklist

- Gather and record the site-specific settings described in ["Gathering Information" on page 151](#).
The installation and configuration scripts require this information.

Gathering Information

Review the information in [Table 7-2](#), and then print the ["Password and Installation Settings Printable Worksheet"](#) on page 161. Use it to record your passwords and installation settings.



Notice: Keep your recorded passwords and installation settings in a secure place so that you can access your ztC Endurance system after installation. Keeping this information accessible also helps your authorized Penguin Solutions service representative to access the system in the event of a service call.

[Table 7-1](#) describes the user-configurable passwords required for the software installation. You are prompted for these values only on the command line.

Table 7-1: Password Settings

Password Type	Description
System Passwords	
BMC Web console admin password	<p>Password for the BMC Web consoleadmin user account.</p> <p>You need to set a password for the BMC Web console to support the software installation and troubleshooting, but you can also use the BMC Web console to remotely monitor and administer the system as summarized in "Configuring the BMCs for Remote System Management" on page 189.</p> <p>The password, which is case-sensitive, must be a string of 8 to 16 alphanumeric characters (with an exception for the default password of admin) and must start with an alphabetical character. The following special characters are allowed: - (hyphen), _ (underscore), @ (at-sign), % (percent sign), # (pound sign), \ (backslash), . (period), * (asterisk).</p>
Management zenadmin password	<p>Password for the zenadmin user account of the ztC Endurance Standby OS and Management VM.</p> <p>You log in to the Standby OS to install the system software, as described in "Installing VMware ESXi and Deploying the Management VM" on page 165. Specifying a new password for the zenadmin account during the software installation replaces the</p>

Password Type	Description
	<p>default password (zenadmin).</p> <p>Most users never need to access the console of the Management VM, but you need to set this password for it to support the software installation, system operations, and troubleshooting, if needed.</p> <p>The password, which is case-sensitive, must be a string of 6 to 20 alphanumeric characters and must contain both upper- and lowercase alphabetical characters. It cannot be the same as the username. The following special characters are allowed: - (hyphen), _ (underscore), @ (at-sign), % (percent sign), & (ampersand), # (pound sign), . (period), \$ (dollar sign), * (asterisk), ! (exclamation point).</p>
ESXi root password	Password for the root user account of the ESXi host.

Table 7-2 describes the system and network settings needed for the software installation.

Most settings in Table 7-2 show two **Setting** names:

- Longer setting names in mixed case (for example, **BMCA hostname**) are similar to the command-line prompts in the installation script.
- Shorter setting names in all lowercase letters (for example, **bmca_hostname**) match the names in the installation configuration file. Table 7-2 may not reflect the exact order in which you are asked to supply the settings in the file.

Note:

A ztC Endurance system requires a total of 10 IP addresses on the management network in order to provide and configure full redundancy:



- One for each BMC port (four total)
- One for each embedded **1G MGMT** port for use by each Standby OS (four total)
- One for the ESXi host
- One for the ztC Endurance Management VM

All interfaces must be on the same subnet. You can configure each interface type to use either the static or DHCP protocol. Also, you can configure additional interfaces after the installation process is complete.

Table 7-2: Installation Settings

Setting	Description
System Information Variables	
system_id	<p>Note: Applies only if you are preparing an installation configuration file.</p> <p>The system ID to include in host name construction. For example, if the fully qualified domain name (FQDN) of a system is ocean . abc . com, where ocean is the host name and the DNS domain name is abc . com, the system_id is ocean.</p> <p>This setting is helpful if you are creating installation configuration files for many systems, so you can enter the ID only once at the top of the configuration file, and replace it with the \$SYSTEM_ID variable wherever necessary.</p>
system_domain	<p>Note: Applies only if you are preparing an installation configuration file.</p> <p>The system domain to include in host name construction. For example, if the fully qualified domain name of a system is ocean . abc . com, where ocean is the host name and the DNS domain name is abc . com, the system domain is abc . com.</p>

Setting	Description
	<p>This setting is helpful if you are creating installation configuration files for many systems, so you can enter the domain only once at the top of the configuration file, and replace it with the \$SYSTEM-DOMAIN variable wherever necessary.</p>
<p>system_ nameserver</p>	<p>Note: Applies only if you are preparing an installation configuration file.</p> <p>The system name server to use in name server fields in the installation configuration file. Specify an IP address for this variable, or specify --NONE--.</p> <p>This setting is helpful if you are creating installation configuration files for many systems, so you can enter the name server only once at the top of the configuration file, and replace it with the \$NAMESERVER variable wherever necessary.</p>
<p>BMC Settings</p>	
<p>BMCA hostname bmca_hostname</p>	<p>BMC A host name, where BMC A is the BMC in compute module A. You can specify either the host name or the fully qualified domain name) (FQDN).</p> <p>You connect to this host name or the IP address of BMC A to remotely monitor and manage compute module A with the BMC Web console.</p>
<p>BMCB hostname bmcb_hostname</p>	<p>BMC B host name, where BMC B is the BMC in compute module B. You can specify either the host name or the FQDN.</p> <p>You connect to this host name or the IP address of BMC B to remotely monitor and manage compute module B with the BMC Web console.</p>
<p>BMC network protocol bmc_netproto</p>	<p>BMC IP protocol (dhcp or static).</p>
<p>BMC A eth 0</p>	<p>BMC A eth 0 IPv4 or IPv6 address (IP address/prefix) or leave blank</p>

Setting	Description
bmca_eth0	(for DHCP).
BMC A eth 1 bmca_eth1	BMC A eth 1 IPv4 or IPv6 address (IP address/prefix) or leave blank (for DHCP).
BMC B eth 0 bmcb_eth0	BMC B eth 0 IPv4 or IPv6 address (IP address/prefix) or leave blank (for DHCP).
BMC B eth 1 bmcb_eth1	BMC B eth 1 IPv4 or IPv6 address (IP address/prefix) or leave blank (for DHCP).
Standby OS Settings	
Standby CMA hostname standbya_ hostname	Standby A host name, where Standby A is the Standby OS running on compute module A. You can specify either the host name or the FQDN.
Standby CMB hostname standbyb_ hostname	Standby B host name, where Standby B is the Standby OS running on compute module B. You can specify either the host name or the FQDN.
Standby network protocol standby_netproto	Standby IP protocol (dhcp or static).
Standby CMA IP Address 1 standbya_ ipaddr_1	Standby A IPv4 or IPv6 address (IP address/prefix) or leave blank (for DHCP) for A eno1.
Standby CMA IP Address 2	Standby A IPv4 or IPv6 address (IP address/prefix) or leave blank (for DHCP) for A eno2.

Setting	Description
standby_ ipaddr_2	
Standby CMB IP Address 1 standby_ ipaddr_1	Standby B IPv4 or IPv6 address (IP address/prefix) or leave blank (for DHCP) for B eno1.
Standby CMB IP Address 2 standby_ ipaddr_2	Standby B IPv4 or IPv6 address (IP address/prefix) or leave blank (for DHCP) for B eno2.
Standby Nameserver standby_ nameserver	Standby IPv4/IPv6 name server address or leave blank (for DHCP). Note for installation configuration file users: If you do not want to use a name server and do not want to be prompted for one during the installation, specify --NONE--.
VMware ESXi Settings	
ESXi hostname esx_hostname	Host name of the ESXi host. You can specify either the host name or the FQDN. You connect to this host name or the IP address of your ESXi host to configure and manage your system with ESXi Host Client. For a summary of ESXi Host Client, see "Configuring ESXi Host Client or vSphere Web Client for Remote System Management" on page 189.
ESXi network protocol esx_bootproto	ESXi host IP protocol (dhcp or static).
ESXi IP address	ESXi host IP address.

Setting	Description
esx_ipaddr	
ESXi Gateway esx_gateway	ESXi host IPv4/IPv6 gateway address or leave blank (for DHCP).
ESXi Netmask esx_netmask	ESXi host IPv4 subnet address or leave blank (for DHCP/IPv6 or if prefix is supplied in IP address).
ESXi IPv6 Prefix esx_ipv6_prefix	ESXi host IPv6 prefix or leave blank (for DHCP).
ESXi Nameserver esx_nameserver	ESXi host IPv4/IPv6 name server address or leave blank. Note for installation configuration file users: If you do not want to use a name server and do not want to be prompted for one during the installation, specify --NONE--.
Numerical keyboard type esx_keyboard	Numerical keyboard type, a value in the range [00 - 27]. Type the numerical value (for example, 26 for the US Default keyboard) if prompted by the installation script, and type the text value (for example, Belgian) if using the installation configuration file. For a full list of values, see " Valid Keyboard Types " on page 158.

Setting	Description
	<p>Valid Keyboard Types</p> <ul style="list-style-type: none"> 00: Belgian 01: Brazilian 02: Croatian 03: Czech 04: Danish 05: Estonian 06: Finnish 07: French 08: German 09: Greek 10: Icelandic 11: Italian 12: Japanese 13: Latin American 14: Norwegian 15: Polish 16: Portuguese 17: Russian 18: Slovenian 19: Spanish 20: Swedish 21: Swiss French 22: Swiss German 23: Turkish 24: Ukrainian 25: United Kingdom 26: US Default 27: US Dvorak
<p>Path/URL to the ESXi ISO <code>esx_iso</code></p>	<p>ESXi ISO path or URL. For example, if you copy the ISO into the Standby OS as described in "IV. Transfer the ESXi ISO Image to the ztC Endurance System" on page 176, the location would be similar to: <code>/opt/stratus/install/VMware-VMvisor-Installer-n.n-</code></p>

Setting	Description
	<i>nnnnnnnn.x86_64.iso</i>
zTC Endurance Management VM Settings	
Management VM Name mgmtvm_name	Management VM host name, where the default is <i>ESXihostname-ZTCmgmt</i> . For example, if the ESXi host name is ocean, the Management VM name would be ocean-ZTCmgmt.
Management VM network protocol mgmtvm_netproto	Management VM IP protocol (dhcp or static).
Management VM Domainname mgmtvm_domainname	Management VM DNS suffix name. For example, if the FQDN of the Management VM is ocean-ZTCmgmt . abc . com, the DNS suffix name is abc . com. Note for installation configuration file users: If you do not want to use a management VM domain name and do not want to be prompted for one during the installation, specify --NONE-- .
Management VM IP Address mgmtvm_ipaddr	Management VM IPv4/IPv6 address (IP address/prefix) or leave blank (for DHCP). You connect to this IP address or the host name of the zTC Endurance Management VM to monitor and manage the fault-tolerant aspects of your system with the zTC Endurance console. For more information, see "Using the zTC Endurance Console" on page 223 .
Management VM Nameserver mgmtvm_nameserver	Management VM IPv4/IPv6 name server address or leave blank (for DHCP). Note for installation configuration file users: If you do not want to use a name server and do not want to be prompted for one during the installation, specify --NONE-- .
zTC Endurance Management Network Settings	

Setting	Description
(Used by BMC, Standby OS, and Management VM)	
Mgmt Gateway zenmgmt_ gateway	Management network IPv4/IPv6 gateway address or leave blank (for DHCP).
Mgmt Netmask zenmgmt_ netmask	Management network IPv4 subnet address or leave blank (for DHCP/IPv6 or if prefix is supplied in IP address).
Mgmt IPv6 Prefix zenmgmt_ipv6_ prefix	Management network IPv6 prefix or leave blank (for DHCP/IPv6 or if prefix is supplied in IP address).
Support Notifications over the ActiveService Network (ASN) Settings	
Enable Support Notifications asn_enabled	Indicates whether or not to enable Support Notifications over the ASN (yes or no). Activating the Support Notifications allows the ztC Endurance system to send health and status notifications to Penguin Solutions Customer Service over a secure Internet connection. To access related settings in ztC Endurance console after installation, see " Configuring Remote Support Settings " on page 271.
Asset ID asn_asset_id	Asset Identifier (ID), in the format <i>zennnnn</i> . This value is required even if you do not enable Support Notifications. For information about locating the asset ID sticker for your system on top of the system chassis, see " Installing the System in a Cabinet " on page 62.

- Make sure you have a **Penguin Solutions Customer Service Portal** account. If you do not already have an account, register for one at <https://support.penguinsolutions.com/csm>.
- Check that you have the most current [Release Notes: Automated Uptime Layer with Smart Exchange Release 1.1.0.4 \(VMware\)](#) and software installation topics for your distribution. To

restore your installation, make sure you have the appropriate version of the release level that you will restore.

- Prepare to accept the end-user license agreements (EULAs) that are presented during the installation process. To locate and read the text of the EULAs you must accept before installing Automated Uptime Layer with Smart Exchange, see "[End-User License Agreements and Warranty](#)" on page 304. You should not perform the installation if you cannot accept the EULAs or are not authorized to accept them. The installation process terminates if you decline any EULAs.

- Consider whether you want to enable Support Notifications over the ASN. Activating Support Notifications over the ASN allows the ztC Endurance system to send health and status notifications to Penguin Solutions Customer Service over a secure Internet connection.

You are prompted to enable or disable Support Notifications over the ASN during the software installation.

- If you are reinstalling a release, back up any data files and prepare backup files to reconfigure the system for security and network operation after the installation procedure is complete.

- With the ztC Endurance system halted, detach most peripheral devices from the system (exceptions are noted below). Devices to detach include:
 - Unsupported PCIe adapters
 - External storage systems
 - USB devices, **except for** the keyboard, mouse, and USB storage device that you use to copy the ESXi ISO during the system software installation



Notice: The installation process cannot accommodate the presence of customer-added or unknown hardware. Add any such hardware, and configure the system to support it, only after completing the installation and verifying that the system functions as expected.

Next Steps

Install the system software. See "[Installing VMware ESXi and Deploying the Management VM](#)" on page 165.

Password and Installation Settings Printable Worksheet

Print the following worksheet and use it to record your passwords and installation settings. Be sure to save this checklist in a secure and accessible location.

After printing this worksheet, return to "[Gathering Information](#)" on page 151.

Table 7-3: Passwords and Installation Settings Worksheet

Setting	Entry
System Passwords	
BMC Web console admin password	
Management zenadmin password	
ESXi root password	
System Information Variables	
system_id	
system_domain	
system_nameserver	
BMC Settings	
BMCA hostname / bmca_hostname	
BMCB hostname / bmcb_hostname	
BMC network protocol / bmc_netproto	
BMC A eth 0 / bmca_eth0	
BMC A eth 1 / bmca_eth1	
BMC B eth 0 / bmcb_eth0	
BMC B eth 1 / bmcb_eth1	
Standby OS Settings	
Standby CMA hostname / standbya_hostname	

Setting	Entry
Standby CMB hostname / standbyb_hostname	
Standby network protocol / standby_netproto	
Standby CMA IP Address 1 / standbya_ipaddr_1	
Standby CMA IP Address 2 / standbya_ipaddr_2	
Standby CMB IP Address 1 / standbyb_ipaddr_1	
Standby CMB IP Address 2 / standbyb_ipaddr_2	
Standby Nameserver / standby_nameserver	
VMware ESXi Settings	
ESXi hostname / esx_hostname	
ESXi network protocol / esx_bootproto	
ESXi IP address / esx_ipaddr	
ESXi Gateway / esx_gateway	
ESXi Netmask / esx_netmask	
ESXi IPv6 Prefix / esx_ipv6_prefix	
ESXi Nameserver / esx_nameserver	
Numerical keyboard type / esx_keyboard	

Setting	Entry
Path/URL to the ESXi ISO / esx_ iso	
ztC Endurance Management VM Settings	
Management VM Name / mgmtvm_name	
Management VM network protocol / mgmtvm_netproto	
Management VM Domainname / mgmtvm_domainname	
Management VM IP Address / mgmtvm_ipaddr	
Management VM Nameserver / mgmtvm_nameserver	
ztC Endurance Management Network Settings (Used by BMC, Standby OS, and Management VM)	
Mgmt Gateway / zenmgmt_gateway	
Mgmt Netmask / zenmgmt_netmask	
Mgmt IPv6 Prefix / zenmgmt_ipv6_prefix	
Support Notifications over the ActiveService Network (ASN) Settings	
Enable Support Notifications / asn_enabled	
Asset ID/ asn_asset_id	

Installing VMware ESXi and Deploying the Management VM

Perform the following steps to install the system software and deploy the Management VM on your ztC Endurance system:

"I. Download VMware vSphere Software" on page 166

"II. Power On the ztC Endurance System and Log On" on page 169

"III. Create the Installation Configuration File (Optional)" on page 171

"IV. Transfer the ESXi ISO Image to the ztC Endurance System" on page 176

"V. Configure BMC Network Settings " on page 178

"VI. Installing VMware ESXi" on page 181



Notice: Do not perform the following procedures until you have performed all of the procedures described in "Preparing to Install the System Software" on page 149.

I. Download VMware vSphere Software

Overview

Before starting the installation process, download VMware ESXi and other VMware vSphere components needed for installation. [Table 7-4](#) describes the installation media.

Table 7-4: Installation Media for VMware ESXi

Software	Description	Obtaining ISO
Stratus ztC Endurance Automated Uptime Layer with Smart Exchange for VMware vSphere	Stratus fault-tolerant system software and Management VM.	You do not need to download the ISO; it was already preloaded into the Standby OS at the factory in preparation for the system software installation.
VMware ESXi	VMware vSphere hypervisor	You must download the ISO.
Guest operating systems	Microsoft Windows, Red Hat Linux, Ubuntu, or other supported operating systems for installation in virtual machines. For more information about guest operating system support on ztC Endurance systems, see <i>VMware by Broadcom Compatibility Guide</i> : https://compatibilityguide.broadcom.com/	You must download the ISO.

Notice:

The USB storage device used during the installation should meet the following requirements:



- It should be a known brand of USB storage device to ensure a successful software installation. For example, Penguin Solutions has successfully tested software installation with SanDisk® brand devices.
- It should be a new USB storage device to avoid introducing malware to your system.
- It should be formatted as NTFS and should have a capacity of at least 16 GB.

Downloading VMware vSphere Software

To download VMware vSphere software

1. Purchase a VMware vSphere license through Broadcom or an authorized reseller. If needed, contact Penguin Solutions Customer Service to determine the type of license necessary for your ztC Endurance system, system resources, and workload.
2. After you purchase the software, you receive a confirmation email that explains how to download the software that you ordered.
3. To install your ztC Endurance system for the first time, download the ISO image for VMware ESXi. You can download any other VMware vSphere software at your convenience.



Note: Ensure that you download an ISO image for ESXi 8.0 Update 3. Automated Uptime Layer with Smart Exchange for VMware vSphere Release 1.1.0.4 supports only VMware ESXi 8.0 Update 3.

4. After the download completes, copy the ISO image to an NTFS-formatted USB storage device. This device is not intended to be bootable.
5. If applicable, set up a vCenter Server system to manage the license keys you received during registration, or prepare to enter a VMware ESXi license key in VMware Host Client or vSphere Web Client after installation. See the VMware vSphere documentation for more information.



Note: Keep your Software License Activation Code Certificates, license keys, and serial numbers in a safe place. You may need them even after the initial software installation for reinstallation or upgrade purposes.

II. Power On the ztC Endurance System and Log On

To power on the system and log on

1. If the ztC Endurance system is already powered on, go to step 2.

If the ztC Endurance system is **not** already powered on, turn on the monitor(s) and press the power button on the control-panel ear of the system (see [Figure 7-1](#) for the location of the power button).

Figure 7-1: Power Button

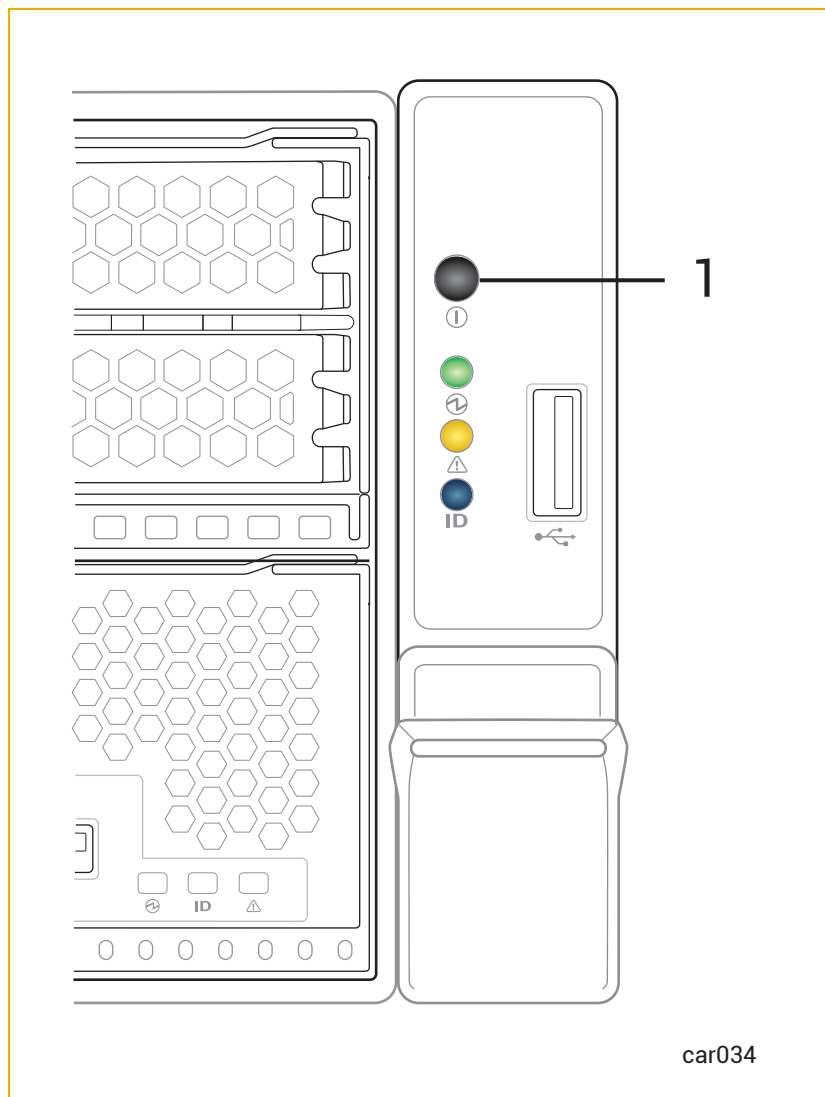

1 Power button

2. Use the keyboard connected to compute module B to log on to the Standby OS as the `zenadmin` user with the default password `zenadmin` (or other credentials, if provided).

III. Create the Installation Configuration File (Optional)

Optionally (but **recommended**), create an installation configuration file, `zen_config.yaml`, that contains the configuration settings that you gathered.

Preparing the Installation Configuration File

You can optionally create an installation configuration file that contains all of the system settings you wrote down on the "[Password and Installation Settings Printable Worksheet](#)" on page 161. (Note that the installation configuration file does not contain your passwords; you are prompted for them on the command line.) This installation configuration file, `zen_config.yaml`, is a template file located in `/opt/stratus/install` that you modify for your specific configuration. This file allows you to enter all of the configuration entries before starting the BMC configuration or software installation, thus avoiding typing mistakes during the installation. This file is also useful if you intend to install more than one system with similar parameters.

You use the same installation configuration file as input to the BMC configuration script (`bmc_config.sh`), software installation script (`install.sh`), or network configuration script (`net_config.sh`). Using this file means that you do not need to manually enter configuration settings while those scripts run.

If you exit out of the software installation script before completing the installation process, the system automatically saves a copy of your latest configuration entries in a configuration file with a time-stamped file name in the `/opt/stratus/install` directory.

Notes:



1. If you use an installation configuration file and leave some settings blank, the installation script prompts you on the command line for those settings.
2. In the installation configuration file, if you inadvertently enter multiple values for the same setting, the installation script uses the last setting listed in the file.

Example of the Installation Configuration File

An example of the `zen_config.yaml` template file follows. (Your template may contain minor differences.)

```
# SYSTEM INFORMATION
system_id:                               # Use '$SYSTEM-ID$' to include in hostname con-
struction
system_domain:                           # Use '$SYSTEM-DOMAIN$' to include in hostname
construction
system_nameserver:                       # Use '$NAMESERVER$' to use this for nameserver fields
below or '--NONE--'

# Information shared by all components on the 1G ztC Endurance management network
# BMCs, Standby, Management VM
zenmgmt_gateway:                         # IPV4/V6 address or None (for dhcp)
zenmgmt_netmask:                         # IPV4 subnet address or None (for dhcp/ipv6/(if pre-
fix supplied in ip))
zenmgmt_ipv6_prefix:                     # IPV6 prefix or None (for dhcp/ipv4/(if prefix sup-
plied in ip))

# BMC
bmca_hostname: $SYSTEM-ID$bmca.$SYSTEM-DOMAIN$ # BMCA hostname (may be a fully qualified domain name)
bmcb_hostname: $SYSTEM-ID$bmcb.$SYSTEM-DOMAIN$ # BMCB hostname (may be a fully qualified domain name)
bmc_netproto:                             # BMC IP protocol ('dhcp' or 'static')
bmca_eth0:                                # BMC A eth 0 IPV4/V6 address(ipaddr/prefix) or None
(for dhcp)
bmca_eth1:                                # BMC A eth 1 IPV4/V6 address(ipaddr/prefix) or None
(for dhcp)
bmcb_eth0:                                # BMC B eth 0 IPV4/V6 address(ipaddr/prefix) or None
(for dhcp)
bmcb_eth1:                                # BMC B eth 1 IPV4/V6 address(ipaddr/prefix) or None
(for dhcp)

# Standby
standbya_hostname: $SYSTEM-ID$a.$SYSTEM-DOMAIN$ # Standby A hostname (may be a fully qualified domain
name)
standbyb_hostname: $SYSTEM-ID$b.$SYSTEM-DOMAIN$ # Standby B hostname (may be a fully qualified domain
name)
standby_netproto:                         # Standby IP protocol ('dhcp' or 'static')
standbya_ipaddr_1:                        # Standby IPV4/V6 address(ipaddr/prefix) or None (for
dhcp) for A eno1
standbya_ipaddr_2:                        # Standby IPV4/V6 address(ipaddr/prefix) or None (for
dhcp) for A eno2
standbyb_ipaddr_1:                        # Standby IPV4/V6 address(ipaddr/prefix) or None (for
dhcp) for B eno1
standbyb_ipaddr_2:                        # Standby IPV4/V6 address(ipaddr/prefix) or None (for
dhcp) for B eno2
standby_nameserver: $NAMESERVER$         # Standby IPV4/V6 address or '--NONE--' (for dhcp)

# ESX
esx_hostname: $SYSTEM-ID$. $SYSTEM-DOMAIN$ # ESX hostname (may be a fully qualified domain name)
esx_bootproto:                            # IP protocol ('dhcp' or 'static')
esx_ipaddr:                               # IPV4/V6 address(ipaddr/prefix) or None (for dhcp)
esx_gateway:                             # IPV4/V6 address or None (for dhcp)
esx_netmask:                              # IPV4 subnet address or None (for dhcp/ipv6/(if pre-
fix supplied in ip))
esx_ipv6_prefix:                          # IPV6 prefix or None (for dhcp/ipv4/(if prefix
```

```
supplied in ip))
esx_nameserver: $NAMESERVER$           # IPV4/V6 address or '--NONE--'
esx_keyboard:                             # ESX keyboard type (e.g. US Default)
esx_iso:                                   # ESX ISO path/URL

# Management VM
mgmtvm_netproto:                          # IP protocol ('dhcp' or 'static')
mgmtvm_ipaddr:                             # IPV4/V6 address(ipaddr/prefix) or None (for dhcp)
mgmtvm_nameserver:      $NAMESERVER$       # IPV4/V6 address or '--NONE--'
mgmtvm_domainname:      $SYSTEM-DOMAIN$    # DNS suffix name or '--NONE--'
mgmtvm_name:              $SYSTEM-ID$-ZTCgmt # Management VM name (default: <ESXi hostname>-
ZTCgmt)

# ASN
asn_enabled:                             # Indicates whether Support Notifications over ASN are
enabled ('yes' or 'no')
asn_asset_id:                             # Asset Identifier

# EOF
```

Creating the Installation Configuration File

The template installation configuration file is located in the Standby OS, which runs Linux. Therefore, you need to use a Linux-based text editor, such as nano or vi, to modify the file. See ["To create or modify zen_config.yaml with nano" on page 174](#) to learn how to use the nano text editor, which is installed on the Standby OS, to modify the file.

To learn more about the nano text editor, see help resources on the web. For example:

<https://www.nano-editor.org/docs.php>

Notes:

1. To use privileged commands in the zenadmin account, you need to add the sudo directive. If you open a file in nano without sudo, you cannot save the configuration file in its original, privileged directory.
2. In the examples, the dollar sign (\$) is the command-line prompt; you do not type it.
3. When the Standby OS boots, you are in the zenadmin home directory, /home/zenadmin. To modify the zen_config.yaml file, you must change to the directory where the file is located: /opt/stratus/install.

To create or modify zen_config.yaml with nano

1. Change the directory from the zenadmin home directory to the directory where the template zen_config.yaml file is located.

```
$ cd /opt/stratus/install/
```

2. Save a copy of the existing template zen_config.yaml file as zen_config.yaml.orig.

```
$ sudo cp zen_config.yaml zen_config.yaml.orig
```

3. Open the `zen_config.yaml` file with the nano text editor.

```
$ sudo nano zen_config.yaml
```

4. When the file opens, use the arrow keys to navigate as you type the settings.



Note: The ^ characters shown on the bottom menu indicate the `Ctrl` key.

5. When you finish editing the file, press `Ctrl X`, then press Y to save the changes or N to discard any changes to the file.

Additional considerations:

- If you forgot to use the `sudo` directive, and the system does not allow you to save the configuration file, you can save your changes to a file in the `/home/zenadmin` directory. Later, you can specify the configuration file's path name on the command line, or you can simply specify its file name if `/home/zenadmin` is the current working directory.
- When typing entries in the configuration file, you must add a space between the colon (:) and the entry text (for example, `bmca_eth0: 10.10.40.32`).
- When you are typing and moving around the file, be careful not to insert any unsupported characters or text that would prevent the installation script from properly reading the file.
- Avoid modifying the configuration file in other operating systems or word processors that might add unsupported line feeds or special characters. Use only a plain text editor such as nano.

IV. Transfer the ESXi ISO Image to the ztC Endurance System

To transfer the ESXi ISO image to the ztC Endurance system with a USB storage device

1. Mount a USB storage device in the Standby OS on compute module B:
 - a. Using the keyboard connected to compute module B, log on to the Standby OS as the zenadmin user with the default password zenadmin (or other credentials, if provided).
 - b. Connect the USB device to one of the USB 3.0 ports on compute module B. To locate the USB 3.0 ports, see [Figure 3-11](#).



Notice: Do not connect the USB device to the USB 2.0 port on the control-panel ear.

- c. Run the `lsblk` command to determine the Linux device name (in the format `sdx`) for the USB storage device. In the following example, the output fragment shows that the USB storage device containing the ESXi ISO was assigned the device ID of `/dev/sde1`.

```
$ lsblk
.
.
sde      8.64    1  14.6G  0  disk
|__sde1  8:65    1  14.6G  0  part   <--- USB device ID
```

- d. Create a directory as a mount point, and mount the USB storage device.



Note: To use privileged commands in the zenadmin account, you need to add the `sudo` directive.

```
$ sudo mkdir -p /mnt/usb
$ sudo mount /dev/sde1 /mnt/usb
```

- e. List the contents of the USB storage device to confirm that the ESXi ISO is present. For example:

```
$ ls /mnt/usb
VMware-VMvisor-Installer-n.n-nnnnnnnn.x86_64.iso
```

2. Copy the ESXi ISO file to the Standby OS on compute module B:

- a. Copy the ESXi ISO to the /opt/stratus/install directory on the Standby OS. For example:

```
$ sudo cp /mnt/usb/VMware-VMvisor-Installer-n.n-nnnnnnnn.x86_64.iso /opt/stratus/install
```

- b. Confirm that the ISO is present in that directory. (Note that the following example shows only the ESXi ISO file, although the directory contains other files.)

```
$ ls /opt/stratus/install
VMware-VMvisor-Installer-n.n-nnnnnnnn.x86_64.iso
```

- c. Unmount the USB storage device so that you can safely disconnect it from the compute module.

```
$ sudo umount /mnt/usb
```

- d. Confirm that the downloaded ISO's checksum matches the MD5 ISO checksum listed on the Broadcom website (<https://support.broadcom.com/>).

V. Configure BMC Network Settings

Overview

Run the Baseboard Management Controller (BMC) configuration script, `bmc_config.sh`, as described in "To configure the BMC network settings" on page 179. Running the BMC configuration script configures the network settings for the BMCs in the ztC Endurance system. You can also configure the BMC network settings in the system BIOS configuration utility, but the BMC configuration script simplifies the changes and allows you to change the configuration on a running system.

Notices:



1. If you do not run the BMC configuration script, the system automatically uses DHCP settings for the BMC network addresses and retains the default BMC Web console password.
2. If you choose to run the BMC configuration script post-installation, you will also need to run the network configuration script (`net_config.sh`).

Notes:



1. If you have the BMC Web console open for either compute module when you change network settings with the BMC configuration script, you will lose your connections. You need to reconnect to the new addresses you entered in the script or configuration file.
2. Although the software-installation script also prompts for changes to the same BMC settings, it is best to modify these settings with the BMC configuration script to prevent network disruptions during the installation procedure.
3. If you need to [modify DDNS settings](#), use the **DNS Configuration** page of the BMC Web Console.

The BMC configuration script is located in `/opt/stratus/bin/bmc_config.sh`.

BMC configuration script usage:

```
Usage : bmc_config.sh {options}
Options:
```

```
-h           prints this menu
-u url      url with ISO image location
-f filename path to ISO image
-y filename path to configuration yaml file
```

Run the BMC configuration script with the installation configuration file (`zen_config.yaml`) to avoid manually entering the configuration settings when running the script.



Note: If you run the `bmc_config.sh` script with the `zen_config.yaml` file, the BMC configuration settings are saved in a new `.yaml` file with a date and time stamp (for example, `config_26042023_180016.yaml`). You can then use the new `.yaml` file with the software installation script (`install.sh`).

Configuring the BMC Network Settings.

To configure the BMC network settings

1. Start the BMC configuration script by running **one** of the following commands:



Note: To use privileged commands in the `zenadmin` account, you need to add the `sudo` directive.

- If you created the installation configuration file: `sudo /opt/stratus/bin/bmc_config.sh -y /opt/stratus/install/zen_config.yaml`

(In the preceding command, if you installed `zen_config.yaml` in a different directory, specify that directory instead.)

- If you did not create the installation configuration file and want to respond to prompts for each setting: `sudo /opt/stratus/bin/bmc_config.sh {options}`

2. The BMC configuration script loads any existing settings from the installation configuration file and begins prompting for input.



Note: If you already entered the settings into the installation configuration file, the BMC configuration script prompts only for the settings you have not entered.

3. The BMC configuration script prompts for the BMC configuration settings. Type new values for the settings you need to change and press `Enter` to continue. To accept an existing value, leave the field blank and press `Enter`. Repeat until the script displays **Confirm input**.
4. The BMC configuration script displays a summary of the settings you entered and prompts you to apply the settings or prompt for each setting again to make any corrections. Do one of the following:
 - To accept the settings that you entered and apply them to the BMCs, type `y` and press `Enter`.
 - To display each prompt again with passwords hidden, type `n` and press `Enter`. For each prompt, type any changes and press `Enter` to continue.
 - To display each prompt again with passwords in clear text, type `unhide`. For each prompt, type any changes and press `Enter` to continue.
5. The BMC configuration script begins to implement the BMC settings that you specified, and then exits.
6. View the output to confirm that the BMC configuration script completed successfully.

VI. Installing VMware ESXi

Overview

After running the BMC configuration script, run the installation script, `install.sh`, as described in ["To install VMware ESXi and Automated Uptime Layer" on page 182](#). Running the installation script automatically:

- Installs VMware ESXi
- Deploys the Management VM
- Installs Automated Uptime Layer components
- Mirrors the pair of system disks
- Mirrors any additional disk pairs in the system, if present

If you want to create a file that already contains the configuration settings needed for the BMC configuration process and software installation process, see ["Preparing the Installation Configuration File" on page 171](#). You can specify this file for input when running the BMC configuration script, software installation script, or network configuration script.

The installation script is located in `/opt/stratus/bin/install.sh`.

Installation script usage:

```
Usage : install.sh {options}
Options:
-h           prints this menu
-u url      url with AUL-SE installer image location
-f filename path to AUL-SE installer ISO image
-y filename path to configuration yaml file
```



Note: To use privileged commands in the `zenadmin` account, you need to add the `sudo` directive.

To run the installation script with no configuration file (prompts for each setting):

```
sudo /opt/stratus/bin/install.sh -f /opt/stratus/install/zen-aul-
se-vmw-n.n.n.n-nnn.iso
```

To run the installation script with a configuration file that already contains settings:

```
sudo /opt/stratus/bin/install.sh -y /opt/stratus/install/zen_
config.yaml
```

In the preceding command, if you installed `zen_config.yaml` in a different directory, specify that directory instead.

If you exit out of the installation script before completing the installation process, the system automatically saves a copy of your latest configuration entries in a configuration file with a time-stamped file name in the `/opt/stratus/install` directory.

The software installation takes approximately 60 minutes.

Installing VMware ESXi and AUL-Smart Exchange

To install VMware ESXi and Automated Uptime Layer

1. Start the software installation script by running the following command:

```
$ sudo /opt/stratus/bin/install.sh -y /opt/stratus/install/zen_
config.yaml
```

(In the preceding command, if you installed `zen_config.yaml` in a different directory, specify that directory instead.)

The software installation script loads any existing settings from the installation configuration file and begins prompting for input.

2. Read the ztC Endurance EULA. To accept the terms and continue, type `y` and `Enter` to continue.
3. Read the ztC Endurance Service Terms and Conditions. To accept the terms and continue, type `y` and `Enter`.
4. The software installation script runs. If you already entered the settings into the installation configuration file, the installation script prompts only for the settings you have not entered. For any settings that you need to enter, see the settings you wrote down on the ["Password and Installation Settings Printable Worksheet"](#) on page 161.
 - a. When prompted to configure the BMC network interfaces:
 - If you have already run `bmc_config.sh`, type `n`, and press `Enter`.
 - If you have not already run `bmc_config.sh`, type `y` to configure the interfaces now or `n` to configure them later, and press `Enter`.



Notice: If you are connected to the console of the compute module through the BMC Web console, you will lose your connection if you change the BMC network settings. If applicable, consider configuring the BMC network settings at a later time as described in ["To configure the BMC network settings" on page 179](#) or ["Updating Network IP Configuration Settings" on page 210](#).

- b. Type the new BMC Web console admin password, the ztC Endurance Management zenadmin password, and the ESXi root password. Type each password and press `Enter` to continue.
- c. If you chose to configure the BMC network interfaces now, type the BMC hostnames. Type each entry and press `Enter` to continue.
- d. Type the BMC network protocol, `dhcp` or `static`, and press `Enter`.
- e. If you selected `dhcp`, skip to the next step; otherwise, if you selected `static`, type the four BMC IP addresses. Type each entry and press `Enter` to continue.
- f. Type the Standby hostnames for each compute module. Type each entry and press `Enter` to continue.
- g. Type the Standby network protocol, `dhcp` or `static`, and press `Enter`.
- h. If you selected `dhcp`, skip to the next step; otherwise, if you selected `static`, type the four Standby IP addresses and name server, if applicable. Type each entry and press `Enter` to continue.
- i. Type the ESXi hostname and press `Enter`.
- j. Type the ESXi network protocol, `dhcp` or `static`, and press `Enter`.
- k. If you selected `dhcp`, skip to the next step; otherwise, if you selected `static`, type the ESXi IP address, gateway, netmask, and name server, if applicable. Type each entry and press `Enter` to continue.
- l. Type the number for your keyboard type, and press `Enter`. For example, for the US Default keyboard, type 26 and press `Enter`.
- m. Type the file path or URL to the ESXi ISO and press `Enter`. For example, if you copied the ESXi ISO to the Standby OS as described in ["To transfer the ESXi ISO image to the ztC Endurance system with a USB storage device " on page](#)

176, the file path would be similar to:

```
/path/VMware-VMvisor-Installer-n.n-nnnnnnnn.x86_64.iso
```

- n. Type the ztC Endurance Management VM hostname and press .
- o. Type the Management VM network protocol, `dhcp` or `static`, and press .
- p. If you selected `dhcp`, skip to the next step; otherwise, if you selected `static`, type the domain name, IP address, and name server for the Management VM. Type each entry, and press to continue.
- q. Type the ztC Endurance Management Network gateway, netmask, and IPv6 prefix, if applicable. Type each entry, and press to continue.
- r. Choose if you want to enable Support Notifications over the ASN. Type or and press .

Activating Support Notifications over the ASN allows the ztC Endurance system to send health and status notifications to Penguin Solutions Customer Service over a secure Internet connection.

- s. Type the Asset ID to your system (`zennnnn`), which is printed on a label located on the top of the system chassis, as shown in ["Installing the System in a Cabinet" on page 62](#). Press .
5. The software installation script displays a summary of the settings you entered and prompts you to begin the installation or prompt for each setting again to make any corrections. Do one of the following:
 - To accept the settings that you entered and begin the installation, type and press . **The installation begins immediately.**
 - To display each prompt again with passwords hidden, type and press . For each prompt, type any changes and press to continue.
 - To display each prompt again with passwords in clear text, type or `unhide`. For each prompt, type any changes and press to continue.
 6. After you confirm your input, the installation script begins to implement the settings that you specified and verify that all system components are ready and properly configured for installation.
 7. Read the VMware EULA. To accept the terms and continue, type and .

After you accept the VMware EULA, the installation script continues the implementation and verification process.

8. When prompted to continue installing ESXi, type `y` and `Enter` to proceed.
9. The installation script automatically installs ESXi, deploys the Management VM, and begins configuring the system software. The script reboots compute module A up to four times while it completes the configuration steps, begins mirroring the pair of system disks, and then mirrors any other pairs of data disks in the system.
10. Upon successful installation of the system, the software installation script displays the current system settings as well as the addresses for the ztC Endurance console and the ESXi Host Client. If you have not already done so, **make note of the settings now to ensure that you have this information.**

The software installation script also displays the `Installation completed successfully.` message.

Next Steps

Configure your system as described in ["Post-Installation Tasks" on page 185](#).

Post-Installation Tasks

After installing the system software, you must complete some post-installation tasks, including:

- ["Verifying the System Software Installation" on page 186](#)
- ["Configuring System Management Options" on page 188](#)
- ["Logging In to the ztC Endurance Console for the First Time" on page 225](#)
- ["Registering the System" on page 243](#)
- Configuring System Preferences:
 - ["Specifying Owner Information" on page 243](#)
 - ["Configuring Remote Support Settings" on page 271](#)
- ["Configuring Users" on page 248](#)
- Configuring e-Alert Notifications:
 - ["Configuring the Mail Server" on page 232](#)
 - ["Configuring e-Alerts" on page 253](#)

- ["Adding and Mirroring Data Disks" on page 209](#)
- ["Configuring Network Interfaces" on page 191](#)
- ["Updating Network IP Configuration Settings" on page 210](#)
- ["Configuring VMware Components and Creating Virtual Machines" on page 212](#)
- ["Considerations When Using VLANs" on page 213](#)
- ["Enabling ASNConnect" on page 215](#)
- ["Changing Passwords on a ztC Endurance System" on page 217](#)

Related Topics

- ["System Software Administration \(VMware\)" on page 209](#)

Verifying the System Software Installation



Notice: When you start or restart the ESXi host, VMware ESXi requires several minutes to start, and then the ztC Endurance Management VM requires additional time to start. If you just restarted your system, `zen_verify` and other utilities can display proper output after 5 to 10 minutes.

To confirm that the system is configured correctly, run the following command in the Standby OS:

```
$ sudo /opt/stratus/bin/zen_verify.sh
```



Note: To use privileged commands in the `zenadmin` account, you need to add the `sudo` directive.

If your system was properly installed, the output appears similar to the following, where all of the tests have passed.

```
$ sudo /opt/stratus/bin/zen_verify.sh
Enter ESXi hostname or IP address:      ocean.abc.com
Enter ESXi password:
Validating entered ESXi credentials...
Enter Management VM password:
Validating entered management VM password...
Host ESXi OS Version check              [PASS]
Host ESXi Stratus vibs check            [PASS]
Host ESXi MPM check                     [PASS]
Host ESXi ZTC portgroup check          [PASS]
```

Host ESXi Network configuration check	[PASS]
Host ESXi Storage configuration check	[PASS]
Management VM OS Version check	[PASS]
Management VM Stratus debian check	[PASS]
Standby Ubuntu OS Version check	[PASS]
Standby Ubuntu debian check	[PASS]
BMC Firmware version check	[PASS]
BIOS Firmware version check	[PASS]
SES Firmware version check	[PASS]
CPLD Firmware version check	[PASS]
Smart Exchange compatibility	[PASS]
Host ESXi-Management VM communication	[PASS]

The test descriptions are as follows:

- Host ESXi OS Version check
Verifies that the ESXi host is running the supported version of VMware ESXi.
- Host ESXi Stratus vibs check
Verifies that the ESXi host contains the correct Stratus-specific vSphere Installation Bundles (VIBs).
- Host ESXi MPM check
Verifies that the Stratus MPM boot volume is properly configured and mirrored between storage modules. That is, it checks that all disks are part of a mirror.
- Host ESXi ZTC portgroup check
Verifies that the ztC Endurance management network port group on the ESXi host is properly configured and redundant between I/O modules. That is, it checks that the vSwitch used by the management VM is configured with the expected port groups.
- Host ESXi Network configuration check
Verifies that all vSwitches and port groups have the expected number of active uplinks and that the uplinks are paired according to their slot assignments.
- Host ESXi Storage configuration check
Verifies that all disk mirrors are configured for redundant operation. That is, it checks that all disk mirrors contain two disks and are paired according to their slot assignments.
- Management VM OS Version check

Verifies that the ztC Endurance Management VM is running the supported version of the Ubuntu operating system (OS).

- Management VM Stratus debian check

Verifies that the ztC Endurance Management VM contains the correct baseline packages from Debian/GNU Linux.

- Standby Ubuntu OS Version check

Verifies that the ztC Endurance Standby OS is running the supported version of the Ubuntu OS.

- Standby Ubuntu debian check

Verifies that the ztC Endurance Standby OS contains the correct baseline packages from Debian/GNU Linux.

- BMC Firmware version check

Verifies that the system's base management controller (BMC) firmware is up to date.

- BIOS Firmware version check

Verifies that the system's basic input/output system (BIOS) firmware is up to date.

- SES Firmware version check

Verifies that the system's SCSI enclosure services (SES) firmware is up to date.

- CPLD Firmware version check

Verifies that the system's complex programmable logic device (CPLD) firmware is up to date.

- Smart Exchange compatibility

Verifies that the compute modules are compatible for Smart Exchange. That is, the compute modules have the same BIOS version, the same ce_mod version, and the same amount of memory.

- Host ESXi-Management VM communication

Verifies that the ESXi host and ztC Endurance Management VM can communicate with each other to keep the system in sync and running in fault-tolerant mode.

Configuring System Management Options

Although you can manage some aspects of your ztC Endurance system from a monitor and keyboard connected to the system (the local console), you typically manage all aspects of the VMware ESXi host and your virtual machines from a remote management system.

For information about configuring remote system-management options for your system, see the following topics:

- ["Logging In to the ztC Endurance Console" on page 226](#) and ["Using the ztC Endurance Console" on page 223](#)

Use the ztC Endurance console to monitor system status and manage fault-tolerant aspects of your ztC Endurance system from a remote management system.

- ["Configuring the BMCs for Remote System Management" on page 189](#)

Use the BMC Web console to perform lights-out management or open a connection to the local console of the ztC Endurance system from a remote management system.

- ["Configuring ESXi Host Client or vSphere Web Client for Remote System Management" on page 189](#)

Use ESXi Host Client or vSphere Web Client to configure and manage the ESXi host and its virtual machines from a remote management system.

- ["Configuring SSH for Remote System Management" on page 190](#)

Use a secure shell (SSH) client to log on to the ztC Endurance Management VM (or the ESXi Shell, if enabled) from a remote management system and manage your ztC Endurance system at the command-line level.

For information about additional system management options, see the VMware vSphere documentation.

Configuring the BMCs for Remote System Management

Use the BMC Web console to administer your ztC Endurance system from a remote management system running Windows or Linux. BMC Web console allows you to monitor the state of your system, power the system on and off, manage the configuration of your ESXi host and view ESXi logs, or open a terminal session to the ESXi Shell (if enabled).

For more information about using the BMC Web Console, see ["Overview of the BMC Web Console" on page 277](#) and ["Accessing Documentation from the BMC Web Console" on page 280](#).

If you need to configure the BMC IP addresses, see ["V. Configure BMC Network Settings " on page 178](#).

Configuring ESXi Host Client or vSphere Web Client for Remote System Management

Use ESXi Host Client or vSphere Web Client to configure and manage the ESXi host and its virtual machines from a remote management system.

To manage a standalone ESXi host, use ESXi Host Client. To access ESXi Host Client, open a Web browser and enter the IP address or fully qualified ESXi host name that you specified during the installation process. For example:

<http://vmwarehost.yourdomain.com>

To manage groups of ESXi hosts associated with a vCenter Server system, use vSphere Web Client. If applicable, install vCenter Server on a remote management system running Windows or Linux. Then, install the VMware vSphere Web Client (Server) component on the vCenter Server system (or on another system in your vSphere environment) and register vSphere Web Client with your vCenter Server system.

To access vSphere Web Client and manage your ESXi hosts, open the URL to your vCenter Server system:

<https://vCenterServer.yourdomain.com/>



Notice: The **Hardware** tab (on the **Monitor** page of ESXi Host Client) and the **Hardware Status** tab (on the **Monitor** tab for your ESXi host in vSphere Web Client) display inaccurate and incomplete information about ztC Endurance systems. To display status and sensor information specific to ztC Endurance systems, open the ztC Endurance console in a Web browser, as described in "[Using the ztC Endurance Console](#)" on page 223.

If you use either ESXi Host Client or vSphere Web Client to connect CD, DVD, or USB media to virtual machines on your ESXi host, install the VMware Remote Console (VMRC) on the management PC running either client. When remote media is needed, launch the VMRC from either ESXi Host Client or vSphere Web Client and connect the media.

For detailed information about installing and using these and other management options in a VMware vSphere environment, see the VMware vSphere documentation.

Configuring SSH for Remote System Management

Use a secure shell (SSH) client to log on to the ztC Endurance Management VM (or the ESXi Shell, if enabled) from a remote system and manage your ztC Endurance system at the command-line level. You may need to download additional software to make this possible on some remote systems.

For example, to manage your ztC Endurance system from a Windows system, you can download and use PuTTY, a suite of open-source SSH clients:

<http://www.chiark.greenend.org.uk/~sgtatham/putty/download.html>

In particular, the `putty.exe` program allows you access a shell to execute programs on the command line, similar to the Telnet protocol, but using secure encryption.

PuTTY also includes the `pscp.exe` command-line utility that allows you to securely transfer files from a remote system to the ESXi host. For example, if necessary, you can use `pscp.exe` to transfer new firmware files or configuration files to the system.

If you prefer a secure copy (SCP) client with a graphical user interface, you can also try the open-source WinSCP utility:

<http://winscp.net/eng/index.php>

On many Linux and UNIX systems, SSH utilities are already installed and enabled by default. See `ssh(1)` and `scp(1)` for information about how to use these utilities.

Configuring Network Interfaces

The installation process automatically configures one embedded 10GbE port from each I/O module into a vSwitch with port groups to support the ESXi Management Network and a VM Network for virtual machine traffic. The remaining embedded Ethernet ports and any optional, non-embedded Ethernet PCIe adapters are unassigned. You must manually configure the unassigned network adapters into vSwitches for fault tolerance, and then assign the vSwitches to port groups based on the virtual machines you intend to connect, your network environment, and performance considerations.



Note: When you add a new vSwitch, be sure to configure NIC teaming with **Failback** set to **no**, and with **Failover order** set to **active/active**.

For additional information about performance and load-balancing considerations in a VMware vSphere environment, see the VMware vSphere documentation.

Upgrading the System Software

Use the instructions in this topic to upgrade the Automated Uptime Layer with Smart Exchange system software on a Stratus ztC Endurance system from Release 1.0.x.x) to Release 1.1.x.x. Upgrading the system includes upgrading the following:

- Management VM software (Ubuntu)
- VMware ESXi hypervisor software and Stratus proprietary add-ins
- Compute module BMC firmware, BIOS firmware, and Standby OS software (Ubuntu)

Notes:

- For the latest information about upgrade paths and restrictions, see the [Release Notes: Automated Uptime Layer with Smart Exchange Release 1.1.0.4 \(VMware\)](#).
- Consider scheduling a maintenance window during which you can complete the upgrade process, which takes approximately **3 hours**. Because the system needs to upgrade software and firmware on both the A- and B-sides of the system, it must shut down the virtual machines and the ESXi host halfway through the upgrade to perform a reboot exchange to the upgraded side and continue upgrading software and firmware on the other side. (The ESXi host restarts only once during the upgrade process. The Standby OS in each compute module restarts additional times, but it does not affect the availability of the virtual machines.)

You can manage the downtime for your virtual machines in one of two ways:

- To minimize downtime for your virtual machines, you can allow them to keep running during the upgrade. Approximately **1.5 hours** through the upgrade, the system automatically shuts down both the virtual machines and the ESXi host, performs a reboot exchange to reprovision the storage and devices, and starts the ESXi host and virtual machines on the side that was already upgraded. If the virtual machines are properly configured to autostart, downtime for this reboot exchange process may take approximately **20-25 minutes**, depending on how many virtual machines are present and how long it usually takes to shut down and restart them.
 - Alternatively, you can shut down the virtual machines before the upgrade starts. If the virtual machines are properly configured to autostart, they start immediately after the reboot exchange for a total downtime of approximately **1.5 hours**.
- To minimize downtime, it is important to confirm that your virtual machines are properly configured to autostart when the ESXi host starts. If you do not want the virtual machines to start until after you have verified the success of the upgrade, you can optionally disable autostart, but remember to re-enable it after the upgrade. For information about managing autostart settings, see the VMware vSphere documentation.

Do not change the autostart setting on the Management VM, which must run at all times to ensure the proper fault-tolerant operation of your system and manage upgrade operations.





- Before performing an upgrade on a system in use, ensure that you have backed up all of your virtual machines.
- To ensure the success of the upgrade process, remove snapshots for all virtual machines in the ESXi Host Client or vSphere Web Client before starting the upgrade. The upgrade will not proceed if any snapshots are present.
- Verify that the system is in good health before upgrading the system software. All modules must be running and not in maintenance mode. In the ztC Endurance console, resolve any alerts on the **Dashboard** page before continuing with the upgrade. The masthead must display a green check mark (✓) and **System is Healthy** with no outstanding issues; otherwise, the upgrade will not proceed.
- During the upgrade process, you temporarily lose access to the ztC Endurance console for 1-2 minutes when the Management VM restarts on the newly upgraded software, and later for about 15-20 minutes when the system performs the reboot exchange to the newly upgraded side of the system. When the ztC Endurance console returns, refresh your web browser and log in again.
- Upgrading from Automated Uptime Layer with Smart Exchange Release 1.0.x.x to a higher release adds a new **Upgrade Kits** page to the ztC Endurance console for managing upgrade kits and monitoring upgrades in progress. The **Upgrade Kits** page becomes available after the system upgrades and restarts the Management VM, about 10-15 minutes after you start the upgrade. Thereafter, you can use the **Upgrade Kits** page to monitor the completion of the upgrade as described in the upgrade procedure.
- If a software upgrade is in progress, do not upload another upgrade kit on the **Upgrade Kits** page of the ztC Endurance console. Doing so will disrupt the upgrade.
- After upgrading, you need to register your ztC Endurance system, download a license file, and apply the license file as described in "[Registering the System](#)" on page 243. (If you need to use ASNConnect to allow service personnel to remotely diagnose your system as described in "[Enabling ASNConnect](#)" on page 215, the system must have an active license installed before you enable the ASNConnect software.)
- In Automated Uptime Layer with Smart Exchange Release 1.0.0.0, the system enabled Ubuntu OS unattended upgrades in the Management VM by default. If your system was connected to the Internet at any time after you installed Release 1.0.0.0, and it has downloaded updates later than the original Release 1.0.0.0 Ubuntu software packages, the system requires access to the Internet during the upgrade process to Release 1.1.0.0 or higher to resolve package dependencies. (If your

system has never been connected to the Internet, you do not need to connect it for the upgrade.)



- When you upgrade to Release 1.1.0.0 or higher, the system permanently disables Ubuntu unattended upgrades in the Management VM. To prevent incompatibilities and ensure the proper fault-tolerant operation of your system, do not enable Ubuntu unattended upgrades in the Management VM or Standby OS.
- When you upgrade to Release 1.1.0.0 or higher, the system completely reinstalls and overwrites the Standby OS in each compute module. If needed, save any custom files from the Standby OS before the upgrade, and always avoid modifying the Standby OS and Management VM unless instructed to do so.
- When the upgrade process replaces the Management VM with a new Management VM, it renames the old Management VM to `old-date` in its suffix. The new Management VM has the same name that the old one had before it was renamed.



Caution: Do not update the Ubuntu system software of the Management VM or Standby OS from any source other than Stratus unless instructed to do so. To prevent incompatibilities and ensure the proper fault-tolerant operation of your system, use only the release and software packages that are installed with the Automated Uptime Layer with Smart Exchange software.



Caution: If you upgrade any software or firmware outside of the documented process for upgrades, the ztC Endurance system automatically reinstalls and reverts to the versions of software or firmware that are compatible with Automated Uptime Layer with Smart Exchange. If the system needs to revert to an earlier BIOS revision, it automatically triggers a reboot exchange with downtime of approximately 20-25 minutes for the virtual machines as previously described.



Caution: The system is not fault tolerant during an upgrade. The system will not be completely protected and able to perform a Smart Exchange until after the upgrade is complete and all modules are online.

The upgrade steps are:

"I. To download the upgrade files" on page 196

"II. To upload the upgrade files to the system" on page 198

"III. To verify the ESXi network configuration" on page 199

"IV. To upgrade the system software" on page 201

"V. To complete post-upgrade tasks" on page 207

I. To download the upgrade files

To download the Automated Uptime Layer with Smart Exchange upgrade kit and upgrade program, you need access to the **Penguin Solutions Customer Service Portal**. Log in to the portal and download the software as follows.

To download the Automated Uptime Layer with Smart Exchange upgrade kit and program

1. Click the following link to access the **Penguin Solutions Customer Service Portal**:
<https://support.penguinsolutions.com/csm>
2. Click **Login**, enter your credentials, and click **Sign In**.
3. On the **Welcome to Customer Service** page, click **Software Downloads**.
4. On the **Software Downloads** page, select your product, operating system, and model. For example, if you want to download the upgrade files for a ztC Endurance system running Automated Uptime Layer with Smart Exchange for VMware ESXi, select the following values:
 - a. Under **Product**, select **ztC Endurance**.
 - b. Under **Operating System**, select **ESXi**.
 - c. Under **Model**, select the model you want.

The **ztC Endurance - ESXi Downloads** are displayed.

5. Click **Upgrade Kit & Program**.
6. Locate the files for **System Software Build 1.1.0.0**. Download the following files, all of which are required for the upgrade process:
 - System Software Build **1.1.0.0** for VMware vSphere zenupgrade Program
 - System Software Build **1.1.0.0** for VMware vSphere Upgrade Kit SHA256sum
 - System Software Build **1.1.0.0** for VMware vSphere Upgrade Kit

To download the required VMware ESXi upgrade depot, you need access to the Broadcom[®] Support Portal. Log in to the portal and download the upgrade depot using instructions similar to the following.

To download the VMware ESXi upgrade depot

1. Click the following link to access the Broadcom Support Portal:
<https://support.broadcom.com>
2. Click **Login** and enter your credentials to log in to the portal.
3. In the top navigation bar, to the left of your account name, click the product pulldown menu and select **VMware Cloud Foundation**.
4. In the left navigation bar, click **My Downloads**.
5. In the search box, type **VMware vSphere**. In the search results, click **VMware vSphere**.
6. In the list of VMware vSphere products, click the version to which you are licensed (for example, **VMware vSphere - Enterprise Plus**).
7. In the list of releases, click **8.0**.
8. Locate the entry for **VMware vSphere Hypervisor (ESXi)** and click **View Group**.
9. In the release pulldown menu in the upper-right corner, select release **8.0U2**.
10. Download the **VMware vSphere Hypervisor (ESXi) Offline Bundle**. The filename is **VMware-ESXi-8.0U2-22380479-depot.zip**.



Note: You must download the ESXi depot file for this exact **8.0U2** release and build number **22380479**, which is the only build supported with Automated Uptime Layer with Smart Exchange Release **1.1.0.0**. **Do not unzip the depot file; the upgrade program expects a zip file.**

II. To upload the upgrade files to the system

After downloading the upgrade files from the **Penguin Solutions Customer Service Portal**, upload the files from the remote management computer to the Management VM of the ztC Endurance system.

To upload the upgrade files, use options including the following:

- To upload the upgrade files over the network, use a secure copy (SCP) utility. For information about downloading an SCP utility to use for file transfers, see ["Configuring SSH for Remote System Management" on page 190](#).
- To upload the upgrade files with a USB storage device, use the VMware Remote Console to connect the storage device to the Management VM as described in the VMware vSphere documentation. To mount the USB storage device at the command line of the Management VM, you can use commands similar to those described in ["To transfer the ESXi ISO image to the ztC Endurance system with a USB storage device " on page 176](#) to determine the device name, create a directory as a mount point, and mount the device; however, remember that you are transferring files to the Management VM (and not the Standby OS) in this case.

Using either option, upload the following upgrade files to the `/home/zenadmin` directory of the Management VM:

- `zenupgrade program`
- `Upgrade kit (.kit)`
- `Upgrade kit SHA256sum file (.sha256)`
- `ESXi upgrade depot (-depot.zip)`

III. To verify the ESXi network configuration

If you performed certain advanced ESXi network configuration actions on your system running Automated Uptime Layer with Smart Exchange Release 1.0.x.x, the changes could cause the upgrade to Release 1.1.x.x or higher to fail. To ensure the success of the upgrade, perform the following steps before beginning the upgrade procedure:

1. Start by enabling ESXi Shell access to the ESXi host:
 - a. Log in to the ESXi Host Client, click **Manage** in the left navigation pane, and click **Users**.
 - b. If **Shell Access** is not enabled for the root user, select the root user, click **Edit User**, and activate the **Enable Shell Access** check box.

2. Open an ssh connection to the ESXi host as the root user.

3. Execute the following command to save the vmknic configuration to a file:

```
# /usr/lib/vmware/configmanager/bin/configstorecli config current  
get -c esx -g network -k vmknics > /var/tmp/vmknics.orig-1.0.json
```

4. Open the /var/tmp/vmknics.orig-1.0.json file in the vi text editor, as follows:

```
# vi /var/tmp/vmknics.orig-1.0.json
```

To learn more about using vi, see help resources on the web. For example:

<https://www.redhat.com/sysadmin/get-started-vi-editor>

5. In the file, locate the vmk0 entry, which is within brackets {} starting with the following device line:

```
{  
"device": "vmk0"
```

6. Examine the list of items immediately before the closing bracket of the vmk0 entry, and do one of the following:

- If one of the lines starts with `nic:`, continue with the following steps.
- If none of the lines start with `nic:`, then no additional action is needed. Close the text editor without saving the file (type `:q!`), skip the rest of the steps in this procedure, and proceed with the upgrade.

For example, a line that begins with `nic:` might appear similar to the following:

```
"mac_mode": "PNIC_BASED",  
"nic": "vmnic0",  
"net_stack_instance_key": "defaultTcpipStack",  
"port_connection_type": "VSS_PORT_GROUP",  
"port_group": "VMkernel",  
"tso_mss": 0  
}
```

7. If a `nic:` line exists, remove only that line from the file and save the changes to a new file to avoid overwriting the `-orig` file that contains the original settings. For example, do the following:
 - a. In the `vi` text editor, move the cursor to the `nic:` line
 - b. Type `dd` to delete the current line.
 - c. Type `:w /var/tmp/vmknics.new-1.0.json` to save the settings to a new json file
 - d. Type `:q!` to close the text editor without overwriting the original json file.
8. Run the following command to save the updated settings to the configuration store:

```
$ /usr/lib/vmware/configmanager/bin/configstorecli config current  
set -c esx -g network -k vmknics -j /var/tmp/vmknics.new-1.0.json
```
9. In the ESXi Host Client, reboot the ESXi host to implement the changes.
10. When you finish using the ESXi Shell, disable it to secure your system. Repeat step 1 of this procedure, except disable ESXi Shell access by clearing the check box for **Enable ESXi Shell**.

You can now proceed with the upgrade.

IV. To upgrade the system software

In the following procedure, to initiate the system software upgrade, use the `zenupgrade` program.

If you followed the instructions in the previous procedure, the upgrade program is located in the Management VM in `/home/zenadmin`.

Upgrade program usage:

```
Usage : zenupgrade_version {options}

Options:
-d filename    VMware ESXi upgrade depot (.depot.zip) file
-k filename    ztC Endurance upgrade kit (.kit) file
-p password    ztC Endurance console administrative password
-u username    ztC Endurance console administrative username
                (for example, the default admin account)
```



Note: To use privileged commands in the `zenadmin` account, you need to add the `sudo` directive.

To run the `zenupgrade` program, for example:

```
sudo ./zenupgrade_n.n.n.n-nnn -k ztcEndurance_upgrade_n.n.n.n-nnn.kit -d VMware-ESXi-n.nnn-nnnnnnnn-depot.zip -u admin -p password
```

The `zenupgrade` program saves log information from the upgrade process in the Management VM in `/var/log/sra-mgmt/zenupgrade_n.n.n.n-nnn_timestamp_log.txt`.

To upgrade from Automated Uptime Layer with Smart Exchange Release 1.x.x.x to a higher release

1. Ensure that you uploaded the `zenupgrade` program, ztC Endurance upgrade kit, and ESXi upgrade depot to the Management VM as discussed in the previous procedures.
2. In the ztC Endurance console, verify that the system is healthy with no outstanding alerts. Resolve and clear any alerts; otherwise, the upgrade will not proceed.
3. If applicable, in the ESXi Host Client or vSphere Web Client, shut down the virtual machines (except for the Management VM) in preparation for the upgrade; otherwise,

the system will automatically shut down and restart them about halfway through the upgrade process.

4. Use one of the following methods to log in to the Management VM as the `zenadmin` user.
 - Open a connection with an SSH client. See "[Configuring SSH for Remote System Management](#)" on page 190 for more information.
 - From the ESXi Host Client or vSphere Web Client, open a browser console window or remote console window. See the VMware vSphere documentation.
5. Before starting the upgrade, you must disable the ActiveService Network (ASN) on the ztC Endurance system to prevent any ASN activity during the upgrade. (Note that simply disabling the ASN on the **Support Configuration** page of the ztC Endurance console is not enough in all cases.)

On the command line of the Management Appliance, execute the following commands to disable the ASN service:

```
$ sudo systemctl stop callhome
$ sudo systemctl disable callhome
```



Note: To use privileged commands in the `zenadmin` account, you need to add the `sudo` directive.

You can restart the ASN service after the upgrade, as described in "[V. To complete post-upgrade tasks](#)" on page 207.

6. On the command line of the Management Appliance, ensure that you are in the directory that contains the `zenupgrade` program, the upgrade kit, the upgrade kit SHA256sum file, and the VMware ESXi upgrade depot. If you followed the instructions in the previous procedures, these files are located in `/home/zenadmin`. For example:

```
$ cd /home/zenadmin
```

7. Execute the following command to verify the integrity of the upgrade kit (`.kit`) file by comparing its checksum to the one provided in the SHA256sum (`.sha256`) file:

```
$ sha256sum -c ztcEndurance_upgrade_n.n.n-nnn.sha256
```

If the checksum matches, the command indicates that the kit file is **OK**. If the checksum does not match, delete the kit file, download a new copy, and repeat this step.

- Execute the following command to change the attributes of the zenupgrade program to make it executable:

```
$ chmod +x zenupgrade_n.n.n.n-nnn
```

- Execute the zenupgrade program to begin the upgrade process, as follows:

```
$ sudo ./zenupgrade_n.n.n.n-nnn -k ztcEndurance_upgrade_
n.n.n.n-nnn.kit -d VMware-ESXi-8.0U2-nnnnnnn-depot.zip -u
admin -p password
```

- When prompted, read the Stratus End User License Agreement and the ztC Endurance Service Terms and Conditions. For links to the full text of this and other agreements associated with ztC Endurance, see ["End-User License Agreements and Warranty" on page 304](#). To accept the terms, type yes and press .
- The zenupgrade program prepares the software upgrade components and upgrades the following components of the Management VM:
 - Ubuntu OS
 - VMware ESXi software and utilities
 - Automated Uptime Layer with Smart Exchange software and utilities

When the upgrade program completes these initial tasks, which take 5 to 10 minutes, the system automatically restarts the Management VM on the upgraded software, and you lose your connection to the shell session.



Caution: During the course of the upgrade, the system might display prompts for you to restart the Management VM, ESXi host, or Standby OS to apply changes. However, you must ignore these prompts and allow the zenupgrade program to automatically restart each component at the correct time to ensure a successful upgrade. **If you manually restart any component while the zenupgrade program is still working, the upgrade will likely fail and leave the system in an unusable state.**

Notes:



- Because the Management VM provides the ztC Endurance console, you lose access to the console for 1-2 minutes while the Management VM restarts.
- Refresh your web browser and log in again to display the new ztC Endurance console pages included with this release, including the new **Upgrade Kits** page that you can use to monitor upgrade progress. The **Upgrade Kits** page will not appear in the user interface until you refresh the web browser.

12. To continue monitoring the upgrade progress, open the **Upgrade Kits** page. While an upgrade is in progress, the **Upgrade Kits** page lists the state of the **Host (ESXi)**, **Compute Module A**, and **Compute Module B** as **pending**, **updating component**, or **up to date**. You can also monitor the progress of the upgrade through alerts displayed on the **Dashboard** page.

Caution: The **Upgrade Kits** page allows you to monitor the upgrade; however, there will still be long periods when it appears like there is no progress even while the upgrade continues in the background.



Do not interfere with the upgrade or restart the system; otherwise, you might leave the system in an unusable state. If the upgrade takes longer than 3 hours with no signs of progress on the **Upgrade Kits** page, contact your authorized Penguin Solutions service representative for assistance before proceeding any further.

13. The system automatically continues to complete the following tasks, which take about an hour:
- Upgrades the ESXi host software that is currently running on the active compute module
 - Puts the standby compute module into maintenance mode
 - Shuts down the Standby OS on the standby compute module
 - Upgrades the BMC and BIOS firmware on the standby compute module
 - Reinstalls the Standby OS software (Ubuntu) on the standby compute module
 - Restarts the standby compute module

14. When the standby compute module is up to date, the system automatically initiates a reboot exchange:

- Automatically shuts down any running virtual machines (if applicable)
- Automatically shuts down the ESXi host
- Takes the upgraded compute module out of maintenance mode
- Performs a reboot exchange to reprovision the storage and devices to the upgraded compute module
- Starts the ESXi host and virtual machines (if applicable) on the upgraded compute module

Notes:

- The system automatically initiates the reboot exchange about 1.5 hours into the upgrade process.
- You can monitor when the reboot exchange is about to start, as follows:
 - On the **Dashboard** page, the system clears the **Standby system update is in progress on compute module x** alert.
 - On the **Upgrade Kits** page, the state of **Compute Module x** switches to **Up to date** and the state of the **Host** briefly switches to **Reboot exchange in progress**.



At this point, the system begins to shut down the virtual machines (if applicable) and the ESXi host in preparation for the reboot exchange.

- You lose access to the ztC Endurance console for 15-20 minutes. After the Management VM restarts, refresh your web browser and log in again.
- If any virtual machines were running on the system, you lose access to the virtual machines for about 20-25 minutes during the reboot exchange process.
- After the reboot exchange, no further downtime is needed.

15. After the reboot exchange, when the system is running on the newly upgraded compute module, software, and firmware, the system:

- Puts the standby compute module into maintenance mode
 - Shuts down the Standby OS on the standby compute module
 - Upgrades the BMC and BIOS firmware on the standby compute module
 - Reinstalls the Standby OS software (Ubuntu) on the standby compute module
 - Restarts the standby compute module
 - Takes the standby compute module out of maintenance mode
16. Continue monitoring the upgrade progress on the **Upgrade Kits** page of the ztC Endurance console. At this point, the **Upgrade Kits** page displays the state of the **Host** (ESXi) and the newly upgraded **Compute Module x** as **up to date**, and it displays the state of the standby **Compute Module x** as **updating component**. You can also view the state of the compute modules on the **Dashboard** page.
17. After the system upgrades the standby compute module, the upgrade process is complete. On the **Upgrade Kits** page, the upgrade kit **State** changes to **Applied**.

V. To complete post-upgrade tasks

1. After the upgrade, the system automatically deletes the ESXi upgrade depot and moves the Automated Uptime Layer with Smart Exchange upgrade kit from `/home/zenadmin` to `/opt/stratus/mgmt/upgrade_kits`. Optionally, only if you need to free up disk space in the Management VM, you can delete the upgrade kit and associated files as follows:
 - a. Select and delete the upgrade kit from the ztC Endurance console as described in the ["Upgrade Kits Page"](#) on page 275.
 - b. Delete the files and folders located in `/opt/stratus/mgmt/upgrade_kits` as shown in the following example:

```
$ sudo ls /opt/stratus/mgmt/upgrade_kits
temp_kitDir_nnnnnnnnnn  ztcEndurance_upgrade_1.1.0.0-nnn
ztcEndurance_upgrade_1.1.0.0-nnn.kit
$
$ sudo bash -c "rm -r /opt/stratus/mgmt/upgrade_kits/*"
$ sudo ls /opt/stratus/mgmt/upgrade_kits
$
```

2. In the ztC Endurance console, verify that the system is healthy with no outstanding alerts. Resolve and clear any alerts before continuing.
3. If the ztC Endurance console alerts you to register, register the system, download a license file, and apply the license file as described in ["Registering the System"](#) on page 243.
4. Verify that your system and your virtual machines are functioning properly on the new software.
5. If you disabled autostart for any virtual machines, remember to re-enable it.
6. On the command line of the Management Appliance, execute the following commands to re-enable the ASN service:

```
$ sudo systemctl start callhome
$ sudo systemctl enable callhome
```

If needed, confirm that the ASN connection is working by generating a test alert as described in ["Configuring Remote Support Settings"](#) on page 271.

7. If needed, configure ASNConnect as described in ["Enabling ASNConnect"](#) on page 215. (Your ztC Endurance system must have a valid product license to run ASNConnect.)

Related Topics

- ["System Software Installation and Upgrade \(VMware\)"](#) on page 149
- ["Upgrade Kits Page"](#) on page 275
- ["Using the ztC Endurance Console"](#) on page 223

8

Chapter 8: System Software Administration (VMware)

Read the following topics to learn about tasks needed to administer a ztC Endurance system:

- ["Adding and Mirroring Data Disks" on page 209](#)
- ["Updating Network IP Configuration Settings" on page 210](#)
- ["Configuring VMware Components and Creating Virtual Machines" on page 212](#)
- ["Considerations When Using VLANs" on page 213](#)
- ["Installing Updates and Patches on the ESXi Host" on page 213](#)
- ["Enabling ASNConnect" on page 215](#)
- ["Installing a Custom Security Certificate" on page 216](#)
- ["Changing Passwords on a ztC Endurance System" on page 217](#)

Adding and Mirroring Data Disks

The installation process automatically configures the disks in the top-left slot of each storage module into a Stratus MPM mirrored disk volume. This volume becomes the system disk for the ESXi host.

If any additional disks are present in the system during installation, the installation process automatically configures the disks in matching slots of each storage module into additional Stratus MPM mirrored disk volumes; however, these remaining volumes are unformatted and unassigned. To use the volumes, you need to create VMFS datastores on them in ESXi Host Client or vSphere Web Client.

To create a VMFS datastore, follow the instructions in the *vSphere Storage* guide, but note the following:

- On the **Select Disk/LUN** page, select a mirrored volume on which to create the datastore.
- The **Select Disk/LUN** page displays a list of volumes that are available for formatting. Each existing mirrored volume is displayed as a **Local STRATUS Disk (mpmn)**.

Updating Network IP Configuration Settings

Use the network configuration script if you need to update the network settings for the ztC Endurance system after the initial software installation. For example, you might need to change the network settings if you prepared a system with settings and virtual machines for an end user, but then you need to update the network settings to deploy the system on a different network or subnet, possibly at a new location.

The network configuration script updates network settings for the:

- Baseboard management controllers (BMCs)
- Standby OS of each compute module
- ESXi host
- Management VM



Notice: When you run the network configuration script, it restarts the active compute module twice to complete all of the changes. Because you temporarily lose access to your applications, ensure that you run the script only on a non-production system or during a planned maintenance period.



Notes:

1. If you are preparing for the initial software installation, use the BMC configuration script or the software installation script to configure the network settings instead of using the network configuration script. See the instructions in "[Installing VMware ESXi and Deploying the Management VM](#)" on page 165.
2. If you are connected to the console of the compute module through the BMC Web console, you will lose your connection if you change the BMC network settings. You need to reconnect to the new addresses you entered in the script or configuration file.

If you want to create a file that already contains the new network settings needed for the network configuration script, see "[Preparing the Installation Configuration File](#)" on page 171. You can specify this file for input when running the network configuration script, BMC configuration script, or software installation script.

The installation script is located in `/opt/stratus/bin/net_config.sh`.

Network configuration script usage:

```
Usage : net_config.sh {options}

Options:
-h          prints this menu
-u url      url with ISO image location
-f filename path to ISO image
-y filename path to configuration yaml file
```



Note: To use privileged commands in the zenadmin account, you need to add the sudo directive.

To run the `net_config.sh` script with prompts for each setting:

```
sudo /opt/stratus/bin/net_config.sh -f /opt/stratus/install/zen-aul-se-vmw-n.n.n.n-nnn.iso
```

To run the `net_config.sh` script with a configuration file that already contains settings:

```
sudo /opt/stratus/bin/net_config.sh -y /opt/stratus/install/zen_config.yaml
```

To update the system network settings

1. Optionally, create a file that already contains the configuration settings as described in ["Preparing the Installation Configuration File" on page 171](#); otherwise, be prepared to manually enter the information from ["Gathering Information" on page 151](#).
2. Log on to the Standby OS of either compute module as the zenadmin user.
3. Start the network configuration script by using one of the commands described earlier in this topic.

```
sudo /opt/stratus/bin/net_config.sh {options}
```

4. The configuration script loads any existing settings from the installation configuration file and begins prompting for input.



Note: If you already entered the settings into the installation configuration file, the network configuration script prompts only for the settings you have not entered.

5. Type the current zenadmin password and press `Enter` to continue.

6. Type the current ESX root password and press `Enter` to continue.
7. The script prompts for the IP configuration settings for the BMCs, the Standby OS, the ESXi host, and the Management VM. Type new values for the settings you need to change and press `Enter` to continue. To accept an existing value, leave the field blank and press `Enter`. Repeat until the script displays **Confirm input below**.
8. The script displays a summary of the settings you entered and prompts you to apply the settings or prompt for each setting again to make any corrections. Do one of the following:
 - To accept the settings that you entered and apply them to the system, type `y` and press `Enter`.
 - To display each prompt again with passwords hidden, type `n` and press `Enter`. For each prompt, type any changes and press `Enter` to continue.
 - To display each prompt again with passwords in clear text, type `unhide`. For each prompt, type any changes and press `Enter` to continue.
9. The configuration script begins to implement the network settings that you specified. View the output to confirm that the changes are successful.
10. The current login session to the Standby OS automatically disconnects so that the system can change the network settings for the compute module.
11. After the system restarts, verify that the BMCs, the Standby OS, the ESXi host, and the Management VM are functioning properly.

Configuring VMware Components and Creating Virtual Machines

After you are finished performing the ["Post-Installation Tasks" on page 185](#), you can configure the VMware ESXi host and create your virtual machines.

If you initialized and mirrored any internal data disks during the installation process, you can create VMFS datastores on them now, as summarized in ["Adding and Mirroring Data Disks" on page 209](#).

If you need to configure additional network connections, you can configure port groups and vSwitches as summarized in ["Configuring Network Interfaces" on page 191](#).

If you are planning to use VLANs, be sure to read ["Considerations When Using VLANs" on page 213](#) first.

No additional software is required in your own virtual machines to enable fault tolerance. The ztC Endurance Management VM and Automated Uptime Layer with Smart Exchange manage the uptime of your system. After installing a guest operating system, you need to install only the standard VMware Tools.

Considerations When Using VLANs

zTC Endurance systems support the use of virtual local area networks (VLANs), with the following considerations:

- VLANs are supported only on production networks, not on the zTC Endurance management network.
 - When using VLANs, the zTC Endurance management network 1G connections should be on a different subnet from the production networks.
 - Production networks include the preconfigured 10G embedded network connected to vSwitch0 as well as any additional network connections you have added.
- You configure VLANs post-installation, using ESXi Host Client or vSphere Web Client.
- When you configure VLANs, do not modify the vSwitchZTC.

Installing Updates and Patches on the ESXi Host

Because Stratus supports running Automated Uptime Layer with Smart Exchange together with standard releases of VMware ESXi, you can download patches for VMware ESXi directly from VMware and install them on your system with standard VMware utilities.



Notice: Do not apply security patches to the Ubuntu-based Standby OS or ESX Management VM, as patching of these components could cause operational problems and interfere with future software upgrades. Stratus will release updates of these components as part of zTC Endurance software upgrades.

To determine which patches have been qualified by Stratus for use on zTC Endurance systems, see the following web site:

<https://www.stratus.com/go/support/esxpatchqualification>

Typically, you apply patches to an ESXi host by running VMware Update Manager, which creates a baseline for your host and lists the patches you can install. However, you can also manually download a patch zip file from VMware and install it by executing `esxccli` commands.

For example, start by executing a command similar to the following to list the software profiles in the patch bundle:

```
# esxccli software sources profile list -d /pathname/VMware-ESXi-8.0U3g-24859861-depot.zip
Name                               Vendor           Acceptance Level  Creation Time      Modification Time
-----
ESXi-8.0U3g-24859861-no-tools      VMware, Inc.    PartnerSupported  2025-07-29T00:00:00  2025-07-29T00:00:00
ESXi-8.0U3g-24859861-standard      VMware, Inc.    PartnerSupported  2025-07-29T00:00:00  2025-07-29T00:00:00
ESXi-8.0U3sg-24853260-no-tools     VMware, Inc.    PartnerSupported  2025-07-29T00:00:00  2025-07-29T00:00:00
ESXi-8.0U3sg-24853260-standard     VMware, Inc.    PartnerSupported  2025-07-29T00:00:00  2025-07-29T00:00:00
```

Then, execute a command similar to the following to apply the patch. Use the `-p` option to specify the profile to update from the list in the previous command. For example:

```
# esxcli software profile update -p ESXi-8.0U3g-24859861-standard -d  
/pathname/VMware-ESXi-8.0U3g-24859861-depot.zip
```

The output of this command will display the VIB files that have been installed, removed, or skipped as a result of applying the patch.



Notice: Do not use the `esxcli software vib install` command to apply patches. If you use the `-force` option to apply patches with this command despite the warnings it displays, it may replace some of the Stratus VIB files with standard ESXi VIB files. Replacing Stratus fault-tolerant components will compromise the continuous uptime of your system.

For patches that do not require the ESXi host to be in maintenance mode, you can execute the `esxcli` commands in the ztC Endurance Management VM (or use the VMware Update Manager). If prompted, restart your ESXi host to apply the patch.

For patches that require the ESXi host to be in maintenance mode, properly shut down the Management VM by executing the following command in the VM:

```
# shutdown -h now
```

After the Management VM shuts down, put your ESXi host into maintenance mode and execute the `esxcli` commands in the ESXi Shell (or use the VMware Update Manager). The Management VM will not automatically restart while the host is in maintenance mode, which allows you to complete the patch process. If prompted, restart your ESXi host to apply the patch. After patching the host, when you disable maintenance mode, you can manually restart the Management VM or allow it to automatically restart within 20 minutes of disabling maintenance mode. Remember that your system is not fault tolerant unless the Management VM is running.

For more detailed information about using the VMware update utilities to apply patches to your ESXi host, see the VMware vSphere documentation.

You may install patches at your own discretion after checking the patch qualification list mentioned earlier in this section. However, before installing a new VMware ESXi maintenance release (for example, "VMware ESX 9.0.1.0") or patch release ("VMware ESX 9.n.n.n. or higher"), ensure that the release has been qualified by Stratus and determine if the release requires a companion update to Automated Uptime Layer with Smart Exchange. For a list of supported releases, see the following web site:

<https://www.stratus.com/go/support/ossupportmatrixes>

Use caution when applying software updates from any source. Applying updates indiscriminately may introduce serious problems to your system. For an up-to-date statement of the Stratus support policy on installing updates and patches to the system software, see the following web site:

<https://www.stratus.com/go/support/osupdatereleasepolicy>

Enabling ASNConnect

ASNConnect by BeyondTrust is a third-party remote access solution that allows Penguin Solutions Customer Service to remotely connect to various components of a ztC Endurance system for assistance with diagnostics, troubleshooting, and service/support activities.

ASNConnect allows Penguin Solutions Customer Service to connect remotely to the following:

- On BMC A: the SSH interface and the BMC Web console
- On BMC B: the SSH interface and the BMC Web console
- On the VMware ESXi host: the ESXi Host Client or vSphere Web Client
- On the Stratus Management VM: the SSH interface, the file transfer interface, and the ztC Endurance console
- On the standby compute module: the SSH interface

To use ASNConnect, you must install software on your ztC Endurance system.

Checking Your Connection to ASNConnect

Before you install ASNConnect on your ztC Endurance system, use the `curl` command to make sure that your ztC Endurance system can connect to **asnconnect.stratus.com** over TCP port 443. The following example shows a successful connection.

```
curl -v asnconnect.stratus.com:443
* About to connect() to asnconnect.stratus.com port 443 (#0)
*   Trying 3.145.54.234...
* Connected to asnconnect.stratus.com (3.145.54.234) port 443 (#0)
> GET / HTTP/1.1
> User-Agent: curl/7.29.0
> Host: asnconnect.stratus.com:443
> Accept: */*
>
* Empty reply from server
* Connection #0 to host asnconnect.stratus.com left intact
```

Installing ASNConnect on the ztC Endurance System



Note: You must complete the license registration for your system before attempting to install ASNConnect. See "Registering the System" on page 243 for more information.

1. [Log in to the ztC Endurance console.](#)
2. In the left-hand navigation panel, click **Support Configuration** under **Remote Support**.
3. Click the check box next to **Enable Remote Support Access**. This automatically installs ASNConnect and enables it on Standby B.
4. Click **Save** (or click **Cancel** to restore the previously saved values).



Note: After the installation is complete, perform a Smart Exchange to auto-install and enable ASNConnect on Standby A. See "Using Maintenance Mode" on page 239 for more information.

Your ztC Endurance system is now ready to use ASNConnect.

Related Topics

- ["Post-Installation Tasks" on page 185](#)
- ["ztC Endurance Console" on page 223](#)
- ["Configuring Remote Support Settings" on page 271](#)

Installing a Custom Security Certificate

The ztC Endurance management server automatically initializes itself with a self-signed SSL certificate, allowing communications to the management server to be encrypted without the identity of the certificate holder being verified by a third party. To view details of this certificate, click the warning icon on the left side of the browser's address bar.

If you prefer to install a custom certificate on the server, run the `certificate_installer` script. You can also use this script to revert to the default certificate or to display the current certificate.

The installation script is located in `/opt/stratus/sbin/` and must be run as root. The installer requires a key file containing the private key in addition to the certificate file. Both files must have the `.pem` format.

Installation script usage:

```

$ sudo /opt/stratus/sbin/certificate_installer.sh
To install/recover/display the certificate:

Usage: sudo /opt/stratus/sbin/certificate_installer.sh [Option]
-d, displays current certificate
-r, recovers to default certificate
-c [PATH to certificate.pem] -k [PATH to key.pem], installs the customer cer-
tificate
-h, displays help
$

```



Note: The `certificate_installer` script automatically restarts the management server after any operation that changes the certificate, so you do not need to perform a manual restart after installation.

To install a custom certificate

1. Copy your new, valid certificate and key `.pem` files to the `/tmp` directory of the ztC Endurance Management VM.
2. Issue the following command:

```

$ sudo /opt/stratus/sbin/certificate_installer.sh -c/tmp/cert.pem -
k/tmp/key.pem

```

To revert to the default certificate

```

$ sudo /opt/stratus/sbin/certificate_installer.sh -r

```

To display information about the currently used certificate

```

$ sudo /opt/stratus/sbin/certificate_installer.sh -d

```

Changing Passwords on a ztC Endurance System

A ztC Endurance system requires the following sets of passwords:

- BMC Web console administrator password
- zenadmin password on the Management VM and Standby OS
- ESXi root password
- ztC Endurance console and REST API password

This topic describes these passwords and explains how to update them (when possible) after the installation. See "[Gathering Information](#)" on page 151 to learn more about these passwords.

BMC Web Console Password

To change the BMC Web console administrator password, log in to the BMC Web console as described in "Logging In to the BMC Web Console" on page 279. Click **Settings**, and then click **User Management**. The **User Management** page allows you to set usernames and passwords.



Note: Both BMCs must have an account with the username `admin`, and both BMCs must use the same administrator password.

If you change the password after the installation, you must use the `cfgpasswd` command to notify the system-management software.



Notice: The system-management software uses the same password for IPMI accesses to the BMC. Therefore, if you do not notify the system-management software of a password change, any attempts to access the BMC by the system-management software results in a failure.

To notify the system-management software

1. On the management VM, run the following command:

```
sudo /opt/stratus/sbin/cfgpasswd --bmcadmin
```
2. At the prompt, enter the new BMC administrator password that you created in the BMC Web console.



Note: The `cfgpasswd` command does not change the password; it simply notifies the system-management software of the change.

The following example shows how to use the `cfgpasswd` command.

```
zenadmin@sys001-ztcmgmt:~$ sudo /opt/stratus/sbin/cfgpasswd --bmcadmin
Stopping sra-mgmt...
Enter value for BMC admin password: xxxxxxxxxxxx
Confirm value for BMC admin password: xxxxxxxxxxxx
Installed /opt/stratus/config/install-config.json
Restarting sra-mgmt...
zenadmin@sys001-ztcmgmt:~$
```

Non-administrator users can set up additional usernames and passwords with the BMC Web console without using the `cfgpasswd` command. The system-management software does not use these usernames or passwords and therefore does not need to be notified about them.

zenadmin Password

The system-management software uses the Ubuntu operating system `zenadmin` account on the Management VM and Standby OS for BeyondTrust installation and configuration, support logs, and software upgrades.



Notice: The Management VM and both Standby OSes require the same password for the `zenadmin` account.

To change the `zenadmin` account password

1. Change the password for each Ubuntu instance with the Linux `passwd` command:
 - a. Use the `ssh` command to connect to the Management VM and each Standby OS (for example, `ssh zenadmin@xxx-ztcmgmt.yyy.com`). Note that you must perform a Smart Exchange to connect to each Standby OS.
 - b. Run the Linux `passwd` command.
2. Notify system management about the new password created in the previous steps:
 - a. On the Management VM, run the following command:

```
sudo /opt/stratus/sbin/cfgpasswd --zenadmin
```
 - b. At the prompt, enter the new password.



Note: The `cfgpassword` command does not change passwords. It simply stores an encrypted copy of the password for the management software to use when it needs to access the account protected by the password.

3. Verify the passwords by running the following command on the Management VM and current Standby OS:

```
sudo /opt/stratus/sbin/cfgpasswd --verify
```

ESXi root Password

To change the ESXi root password, use the ESXi Host Client. (See "[Configuring ESXi Host Client or vSphere Web Client for Remote System Management](#)" on page 189 for information about logging in to the ESXi Host Client.) Stratus software does not use this password, so changing it has no impact on your ztC Endurance system.

ztC Endurance Console Passwords

To change ztC Endurance console usernames and passwords, use the ztC Endurance console as described in "[Managing User Accounts](#)" on page 249.

The REST API uses the same usernames and passwords.



Notice: If you change the usernames and passwords, any external application using the REST API must change its usernames and passwords to match.

9

Chapter 9: Using the ztC Endurance Console

The ztC Endurance console is a browser-based interface that provides management and monitoring of a ztC Endurance system from a remote management computer. For an overview of the console and for links to each of the pages within the ztC Endurance console, see ["ztC Endurance Console" on page 223](#).

ztC Endurance Console

The ztC Endurance console is a browser-based interface that provides management and monitoring of a ztC Endurance system from a remote management computer. You can perform many administrative operations from the console because it provides access to the system as a whole as well as to individual modules, components of modules, and other resources.

For information on the requirements of the remote management computer that runs the ztC Endurance console, see ["ztC Endurance Console Requirements" on page 224](#).

Using the options listed in the left pane of the ztC Endurance console, you can perform a variety of administrative functions:

- Read system alerts from the Dashboard. See ["Dashboard Page" on page 229](#).
- Configure the mail server. See ["Configuring the Mail Server" on page 232](#).
- View information about the system and its components. See ["Hardware Page" on page 233](#).
- Monitor resources for volumes, including their state, name, data synchronization status, size, and datastore. See ["Volumes Page" on page 242](#).
- Specify the name and contact information for an administrator or owner of the system. See ["Specifying Owner Information" on page 243](#).
- Register your system. See ["Registering the System" on page 243](#).

- Configure users. See ["Configuring Users"](#) on page 248.
- View alerts. See ["Alert History Page"](#) on page 250.
- View support logs. See ["Support Logs Page"](#) on page 251.
- Configuring notifications. See ["Configuring e-Alerts"](#) on page 253 and ["Configuring SNMP Settings"](#) on page 254.
- Enable OPC functionality. See ["Configuring OPC Settings"](#) on page 264.
- Configure remote support settings to send alerts to Penguin Solutions Customer Service via the Active Service Network (ASN) when an event requires attention. See ["Configuring Remote Support Settings"](#) on page 271.
- Configure proxy settings to support notification messaging and remote support access features. See ["Configuring Internet Proxy Settings"](#) on page 274.
- Upload software upgrade kits. See ["Upgrade Kits Page"](#) on page 275.

In addition, you can use the ztC Endurance console to:

- Edit your user information. See ["Editing Your User Information"](#) on page 228.
- View your system's serial number by hovering the cursor over the ztC Endurance model number at the top of the left pane.
- View the management VM's IP address, the system's software version number, and asset ID in the banner at the top of the ztC Endurance console.

Related Topics

- ["Logging In to the ztC Endurance Console for the First Time"](#) on page 225
- ["Logging In to the ztC Endurance Console"](#) on page 226
- ["Using the ztC Endurance Console"](#) on page 223

ztC Endurance Console Requirements

The ztC Endurance console provides browser-based remote management of the ztC Endurance system, including its processing, storage, networks, and power.



Note: The ztC Endurance console manages the base ztC Endurance system. For ESX-specific functions (for example, VM management), use ESXi Host Client or vSphere Web Client.

- Locate the ztC Endurance console IP address returned at the end of the ESXi installation. (See ["Installing VMware ESXi and Deploying the Management VM"](#) on page 165.) You use this

IP address, which is also the IP address of the ztC Endurance Management VM, to log in to the ztC Endurance console.

- Your computer must be able to access the subnet containing the ztC Endurance management network, which is enabled on the port labeled **1G MGMT**. See [Figure 1-4](#) for the location of this port.
- Use a supported browser. See ["Compatible Internet Browsers" on page 225](#).

Related Topics

- ["ztC Endurance Console" on page 223](#)
- ["Using the ztC Endurance Console" on page 223](#)

Compatible Internet Browsers

A browser is used to connect to the ztC Endurance console. Use only browsers that are compatible with ztC Endurance systems. Using an incompatible browser can result in some rendering problems and the omission of some wizards.

[Table 9-1](#) lists browsers that are compatible with ztC Endurance systems.

Table 9-1: Compatible Browsers

Compatible Browsers	Release
Microsoft Edge	118 or later
Mozilla® Firefox®	118 or later
Google® Chrome™	118 or later

Logging In to the ztC Endurance Console for the First Time



Note: If this is **not** your first time logging in to the ztC Endurance console, see ["Logging In to the ztC Endurance Console" on page 226](#) instead.

When deploying the system, log in to the ztC Endurance console to change the default password.

To log in to the ztC Endurance console for the first time

1. From a networked PC or laptop, type the secure version (**https**) of one of the two management IP addresses of your ztC Endurance system into a browser address bar.



Note: If a security message appears, proceed to the web site. You can add a security exception later, to allow the site to load without the message "Configuring Secure Connections."

2. The login page of the ztC Endurance console appears. Enter **admin** for the **Username** and **admin** for the **Password** (or other credentials, if provided), and then click **LOGIN**.
3. When you see the **Warning** message notifying you to change your password, click **OK**.



Notice: You must change the password for **admin** now, for security purposes. You can change it again later when you update the default user profile for the **admin** account. You make these changes on the **Users** page (see "[Configuring Users](#)" on page 248).

4. On the **Change Password** window, provide the requested password information and click **Continue**. The password must conform to the system's password policy (for information, see [Password Policy](#)).
5. When you see a message saying that your password reset was successful, click **Finish**.
6. When the login page appears, enter **admin** for the **Username** and your new password, and then click **LOGIN**.

The ztC Endurance console appears and the initial login is complete. Bookmark or otherwise make note of the system IP address for use when logging in to the console in the future.

Perform additional tasks in "[Post-Installation Tasks](#)" on page 185, if necessary.

Related Topics

- "[Logging In to the ztC Endurance Console](#)" on page 226
- "[ztC Endurance Console](#)" on page 223

Logging In to the ztC Endurance Console



Note: If this is your first time logging in to the ztC Endurance console, see "[Logging In to the ztC Endurance Console for the First Time](#)" on page 225 instead.

Log in to the ztC Endurance console to manage the ztC Endurance system. Using the console, you can manage the system, including its processing, storage, networks, and power. You can also view alerts and perform other administrative tasks.

Notes:

1. A login session times out after 10 minutes, if unused.
2. The system has a limit of 10 login sessions.
3. A username cannot start with a special character and is limited to 64 characters.
4. Passwords must conform to the system's ["Password Policy"](#) on page 228.

To log in to the ztC Endurance console

1. Type one of the two management IP addresses of your ztC Endurance system or the fully qualified domain name (FQDN) into a browser address bar:

https://IP_address

OR

https://FQDN_name

2. When the login page appears, enter your **Username** and **Password**.

If you have forgotten your password, click **Forgot Password?** and the **Reset Password** page appears. Enter the requested information to reset your password.



Note: Resetting a password requires that you have an email account on the system, with an email address, as configured in your user account (see ["Managing User Accounts"](#) on page 249). If you are unable to receive email, contact your system administrator.

To reset your password



Note: To receive email when resetting your password, the mail server must be configured. See ["Configuring the Mail Server" on page 232](#).

- a. When the **Reset Password** page appears, enter your **Username** and click **Continue**. An email is sent to the email address listed with your local user account. The email contains a link to a reset password page.
- b. In your email account, open the email with the reset-password link, and click the link. The **Reset Password** page reappears.
- c. For **New Password** and **Confirm Password**, type your new password. The new password must conform to the system's ["Password Policy" on page 228](#).
Click **Continue**.
- d. A page appears, with a message that the reset was successful and that you can log in to the system with your new password. Click **Finish**.

3. Click **LOGIN**.

Password Policy

The system's password policy requires that your password meet these conditions:

- Its minimum length is 8 characters, and its maximum length is 72 bytes.
- It must contain both upper- and lowercase characters.

Related Topics

- ["Logging In to the ztC Endurance Console for the First Time" on page 225](#)
- ["ztC Endurance Console" on page 223](#)

Editing Your User Information

Edit your user information (that is, your user profile) by changing your user name, email address, first name, last name, or password.

To edit your user information

1. Click your user name in the upper right-hand corner of the console.

The **Edit User** dialog box opens.

2. Enter or modify values for the following:

- **User Name**
- **Email Address**
- **First Name** (optional)
- **Last Name** (optional)
- **Password**



Note: Passwords must confirm to the system's "Password Policy" on page 228.

- **Confirm Password**

3. Click **Save**. (Or click **Cancel** to cancel the changes.)

Related Topics

- ["ztC Endurance Console" on page 223](#)

Dashboard Page

The **Dashboard** page:

- Displays a summary of outstanding alerts on the ztC Endurance system.
- Allows you to perform a total system shutdown by clicking the **Shutdown** button.



Notice: Do not click the **Shutdown** button unless you are familiar with the topics discussed in ["System Power" on page 84](#).

The **Dashboard** page opens when you log in to the ztC Endurance console. To open it from other pages, in the left-hand navigation panel, click **Dashboard** under **System**.

On the **Dashboard** page:

- The masthead at the top of the page displays information such as the system name, IP address, software version, and asset ID. It also provides registration status, system-alert status, the name of the current user, and the **Logout** option.
- The top pane displays the ztC Endurance system diagram. In addition, the **Shutdown** button appears in the upper-right corner of the top pane, along with a **Help** button that launches the documentation for your version of ztC Endurance in a browser window.
- The bottom pane displays a list of alerts associated with the components shown in the system diagram.

- The left-hand navigation panel displays the pages that allow you to configure or view information about the system. You can also hover over the model name at the top of the navigation panel to view the system's serial number.

To display additional information about outstanding alerts, click an alert symbol (for example, ) in the system diagram, or click an entry in the list of alerts below the system diagram. Alert lists may appear in tabs such as **All**, **System**, and **Ignored**, as well as in tabs for each component shown in the system diagram. These tabs may appear below the system diagram, depending on the alerts. The alert information includes:

- The component associated with the issue (for example, the ztC Endurance system or a module).
- A description of the activity or task that requires attention.
- The reason the issue should be resolved, if available, by clicking the up arrow (^) in the **Action** column. (Hide this information by clicking the down arrow (v)).

Resolve active alerts as soon as possible (see ["Resolving Outstanding Alerts on the Dashboard" on page 231](#)).

Understanding the ztC Endurance System Diagram





The system diagram displays a graphical representation of system status. A star symbol () indicates the active module.

The system diagram also shows which disk-drive slots and PCIe-card slots are populated. If a disk-drive slot is grayed-out in the diagram, that slot is empty. Similarly, if the diagram shows a PCIe-card slot with slot covers instead of a PCIe card with ports, that slot is empty.







Alert symbols, if present, represent informational or critical alerts that require attention. Click an alert symbol to display information about the alert.

Alert Symbols

General alert symbols, in descending order of severity, are:

- Critical or Serious ()
- Moderate ()
- Minor ()
- Informational ()
- Good ()

Device-specific alert symbols include:

- PSU symbols:
 - : Reports an alert on a failing or degraded PSU
 - : Reports a warning alert on a PSU (for example, if the PSU is simplex)
- Disk symbols:
 - : Reports an alert on a failing or degraded physical disk
 - : Reports a warning alert on a physical disk (for example, if the disk is simplex)
- Network symbols:
 - : Reports an alert on a failing or degraded teamed network port.
 - : Reports a warning alert on a teamed network port (for example, if the network port is simplex)

Related Topics

- ["ztC Endurance Console" on page 223](#)

Resolving Outstanding Alerts on the Dashboard

Resolve any outstanding alerts that appear on the **Dashboard** page.

To resolve outstanding alerts

If an alert appears in the ztC Endurance system diagram on the ztC Endurance console **Dashboard** page, click the alert. Information about it appears in the bottom pane. Your options are as follows:

- Resolve the alert.

For instance, if you see a message similar to **Support Notification service should be enabled to ensure the best possible customer support**, enable the support notification service. See ["Configuring Remote Support Settings" on page 271](#).
- For minor alerts, click **Ignore** (beneath the **Action** column) to ignore the alert and remove it from the list. Clicking **Ignore** hides the alert. You cannot ignore more serious alerts.

To restore the ignored alert to the list, click the **Ignored** tab above the alerts list, and then click **Restore**, under the **Action** column.

Related Topics

- ["ztC Endurance Console" on page 223](#)
- ["Dashboard Page" on page 229](#)
- ["Configuring e-Alerts" on page 253](#)

Configuring the Mail Server

Configure the mail server to enable the ztC Endurance system to send email when, for example, a user needs to reset a password, generate a test alert, or receive alerts via email (e-Alerts).

To configure the mail server



Note: If you change any mail-server settings, you **must** re-enter the mail-server password if authentication is enabled.

1. In the left-hand navigation panel, click **Mail Server Configuration** under **System**.
2. On the **Mail Server Configuration** page, click the **Enable Mail Server** box. Boxes for specifying or selecting the following settings appear:
 - **SMTP Server** (required)—Enter the name of the Simple Mail Transfer Protocol (SMTP) server that your company uses to send email.
 - **Port Number**—Enter the port number to use when sending e-Alerts. If no port number is specified, the default SMTP port 25 is used.
 - **Sender's Email Address**—Enable e-Alert delivery by specifying a valid sender's email address in either of the following cases:
 - You have not specified a DNS server on the ztC Endurance system **and** your SMTP server is not configured to accept domain literals (From addresses in the form `noreply@IP_address`).
 - You want the e-Alert to provide a different sender's email address (for example, `noreply@company.com`).

Any email address that the SMTP server accepts is sufficient.

- **Encrypted Connection**—Select a value from the drop-down menu for the encryption protocol that the SMTP server requires:



Note: Regardless of whether you select **TLS** or **SSL**, the ztC Endurance software selects whichever protocol is best at the time of the connection.

- **None** for no encryption. By default, port number 25 is used.
- **TLS** for the Transport Layer Security (TLS) protocol. For TLS, you should specify 587 for **Port Number**, though 25 is used by default. However, check with your network administrator to make sure that 587 is the correct port number.

- **SSL** for the Secure Sockets Layer (SSL) protocol. For SSL, you should specify 465 for **Port Number**, though 25 is used by default. However, check with your network administrator to make sure that 465 is the correct port number.
- **Enable Authentication**—Click this box if the SMTP server requires authentication to send email. Then, type the **Username** and **Password** for the SMTP account.



Note: If authentication is enabled (because the **Enable Authentication** box is already checked or because you have just checked it) and you change any mail server settings, you **must** re-enter the mail-server password.

3. Click **Save** (or click **Cancel** to restore the previously-saved values).

Related Topics

- ["ztC Endurance Console" on page 223](#)

Hardware Page

The **Hardware** page displays information about the hardware components of a ztC Endurance system. The top pane lists the state, activity type, name, and serial number of each compute module, I/O module, storage module, and PSU in the system. The bottom pane displays detailed information about the top-pane component that is currently selected.

When you select tabs in the bottom pane, the information displayed is generally self-explanatory. However, additional information about the [Memory](#), [Network](#), [Fibre Channel](#), and [Storage](#) tabs is provided later in this section.

In addition to viewing information about hardware components, you can use the **Hardware** page to do the following:

- Identify a hardware component by clicking a button to flash its ID LED (see ["Identifying a System or Component" on page 238](#)).
- Place a compute module into maintenance mode, shut it down, and then return it to service (see ["Using Maintenance Mode on Compute Modules" on page 240](#)).
- Go to the BMC login page. From the compute module's **BMC** tab, click an IP address to go to the BMC login page (see ["Logging In to the BMC Web Console" on page 279](#)).
- View operating-system information (name, version, IP address, and hostname) by clicking the compute module's **OS** tab.



Hardware States

The **State** values show the severity of the component's state. Values are:

- Informational ("Using Maintenance Mode" on page 239.

Hardware Activity Types

The **Activity** values show the component's current activity type. Values are:

- **Running** ("Shutting Down and Restarting a Compute Module" on page 241.
- **Shutdown** (

Page 234 of 310

To learn more about the Memory tab

On the **Hardware** page, you can learn more about a specific compute module's memory by selecting the compute module and then clicking its **Memory** tab in the lower pane. The **Memory** columns have the following meanings:

- **State:** Displays the state of the DIMM. For example, a green checkmark in the **State** column indicates that the DIMM's state is good. See ["Hardware States" on page 233](#) for more information about the hardware states and their associated icons.
- **Name:** Displays the name of the DIMM (for example, **DIMM8**).
- **Slot:** Displays which of the two DIMM slots on a channel an DIMM is physically plugged in to. Because ztC Endurance systems implement only one slot per channel, you can ignore the values in this column.
- **Socket:** Displays the processor to which an DIMM is connected. For example, a value of 1 indicates that the DIMM is connected to processor 1.
- **Channel:** Indicates the number of the channel (that is, a physical set of wires) between the processor and the DIMMs. Each processor in a ztC Endurance system has 8 DIMM channels.
- **Capacity:** Displays the size of the DIMM, in gigabytes (for example, **32 GB**).

See ["Memory in ztC Endurance Systems" on page 22](#) for more information about DIMMs.

To learn more about the Network tab

On the **Hardware** page, you can learn more about a system's Ethernet PCIe adapters.

- To learn about a specific compute module's embedded Ethernet PCIe adapters, select the compute module and then click its **Network** tab in the lower pane.
- To learn about a specific I/O module's Ethernet PCIe adapters, select the I/O module and then click its **Network** tab in the lower pane.

The **Network** columns have the following meanings (note that a value of **Empty** indicates that the associated slot is empty):

- **State**: Displays the state of the component. For example, a green checkmark in the **State** column indicates that the PCIe adapter's state is good. See "[Hardware States](#)" on page 233 for more information about the hardware states and their associated icons.
- **Location**: Displays the location of the component. For example, in a compute module, **embedded-A** means that the embedded PCIe adapter is located in PCIe slot A. In an I/O module, **slot B/2** means that the PCIe adapter is located in I/O module B, slot 2 (see "[PCIe-Adapter Physical Slot Numbering](#)" on page 32).
- **Name**: Displays the name of the component (for example, **vmnic0**).
- **Port**: Displays which port the component is connected to (for example, **1**).
- **PCI ID**: Indicates the component's PCIe address identifier on the system (for example, **0000:9e:00.1**).
- **Speed**: Indicates the speed of the component (for example, **10 Gbps**).
- **MAC Address**: Displays the component's MAC address (for example, **34:a6:61:fb:18.94**).

To learn more about the Fibre Channel tab

On the **Hardware** page, you can learn more about a system's Fibre Channel (FC) PCIe adapters by selecting the I/O module and then clicking its **Fibre Channel** tab in the lower pane.



Note: The **Fibre Channel** tab appears only in systems that contain an FC PCIe adapter.

The **Fibre Channel** columns have the following meanings:

- **State:** Displays the state of the component. For example, a green checkmark in the **State** column indicates that the FC PCIe adapter's state is good. See "[Hardware States](#)" on page 233 for more information about the hardware states and their associated icons.
- **Location:** Displays the location of the component. For example, **slot A/2** means that the FC PCIe adapter is located in I/O module A, slot 2.
- **Name:** Displays the name of the component (for example, **vmhba3**).
- **PCI ID:** Indicates the component's PCIe address identifier on the system (for example, **0000:9e:00.1**).
- **Speed:** Indicates the speed of the component (for example, **32 Gbps**).
- **WW Node Name:** Displays the unique identifier for the component (for example, **20:00:f4:c7:aa:3c:10:a5**).
- **WW Port Name:** Displays the unique identifier for the port on the component (for example, **21:00:f4:c7:aa:3c:10:a5**).

To learn more about the Storage tab

On the **Hardware** page, you can learn more about a specific storage module's disks by selecting the storage module and then clicking its **Storage** tab in the lower pane. The **Storage** columns have the following meanings:

- **State:** Displays the state of the disk. For example, a green checkmark in the **State** column indicates that the disk's state is good. See ["Hardware States" on page 233](#) for more information about the hardware states and their associated icons.
- **Location:** Displays the location of the disk. For example, **slot A/6** indicates that the disk is located in storage module A, slot 6.
- **Name:** Displays the name of the disk (for example, **vmhba64:C0:T0:L0**). If the disk slot is empty, **Empty** is displayed.
- **PCI ID:** Indicates the disk's PCIe address identifier on the system (for example, **0001:74:00.0**).
- **Availability:** Indicates if the disk is **Redundant** (that is, paired with another physical disk). If the disk slot is empty, **Unused** is displayed.
- **Logical ID:** Displays the logical ID of the disk (for example, **mpm1**). If the disk slot is empty, **Unconfigured** is displayed.

Related Topics

- ["Removing and Replacing System Components" on page 101](#)
- ["Dashboard Page" on page 229](#)
- ["Disk Drives" on page 28](#)
- ["Memory in ztC Endurance Systems" on page 22](#)
- ["PCIe Adapters" on page 31](#)
- ["System CRU Modules" on page 20](#)
- ["General Servicing Information" on page 101](#)
- ["ztC Endurance Console" on page 223](#)

Identifying a System or Component

You can identify:

- A specific ztC Endurance system in a cabinet
- A specific component within a ztC Endurance system

To identify a ztC Endurance system

Press the **ID** button on the compute module (see [Figure 1-5](#)). The blue ID LED on the control-panel ear (see [Figure 4-2](#)) illuminates for 30 seconds.

To identify a component in a ztC Endurance system

1. In the left-hand navigation panel, click **Hardware** under **System**.
2. In the top pane of the **Hardware** page, select the component that you want to identify and then

click the **Identify** () button. The blue ID LED for that component illuminates for 30 seconds. See "[Status LEDs](#)" on [page 90](#) for the location of each component's ID LED.

Related Topics

- "[Hardware Page](#)" on [page 233](#)
- "[Dashboard Page](#)" on [page 229](#)
- "[Compute Module](#)" on [page 21](#)

Using Maintenance Mode

If you need to take a compute module offline for service, you place it into maintenance mode.



Note: This topic discusses maintenance mode on a ztC Endurance system. Do not confuse it with maintenance mode on an ESXi host; they are unrelated operations. For information about placing an ESXi host into maintenance mode, read this discussion in the [VMware documentation](#).

Using Maintenance Mode on Compute Modules

When [you place a compute module into maintenance mode](#), it goes offline for service. While a compute module is in maintenance mode, operations such as monitoring, recovery, automatic power-on, and so on cannot occur on that compute module.

If you place the **active** compute module into maintenance mode, the system automatically performs a Smart Exchange.

What is Smart Exchange?

Smart Exchange is a Stratus proprietary process that maintains system availability and protects against data loss. If the ztC Endurance system detects a degradation or failure within the active compute module, Smart Exchange:

- Automatically activates the standby compute module and copies over in-process data
- Reroutes all I/O and storage connected to the original active compute module over to the newly activated compute module

Smart Exchange occurs while the system is running and except for a very brief pause (usually, less than one second), is undetectable to the operating system and customer applications.

[You must manually remove the compute module from maintenance mode](#) to return it to service.

Note that when the active compute module enters maintenance mode, the standby compute module becomes active after the Smart Exchange completes. During this operation, communications between the active and standby compute modules are disabled, and the operating system and VMs running on the original active compute module are migrated to the new active compute module. This protects the operating system and running VMs from any potential disruption caused by the operation.

Notices:



1. A compute module must be in maintenance mode before you shut it down. For information about shutting down a compute module, see ["Shutting Down and Restarting a Compute Module" on page 241](#).
2. The system is not fault tolerant when a compute module is in maintenance mode. For continuous uptime, finalize service as soon as possible so that the compute module can exit maintenance mode and go back online.

To place a compute module into maintenance mode

1. From the **Hardware** page, select a compute module.
2. Click **Work On**.
3. Click **Yes** on the **Confirm** window.

When the compute module is in maintenance mode, its state appears as **Maintenance Mode**, and its **Activity** displays as **Running**. At this point, it is safe to [shut down the compute module](#) if necessary.

To remove a compute module from maintenance mode

1. From the **Hardware** page, select the compute module that is in maintenance mode.
2. Click **Finalize**, which removes the compute module from maintenance mode.

When the compute module exits maintenance mode, its state appears as **Normal**, and its **Activity** displays as **Running**.

Related Topics

- ["ztC Endurance Console" on page 223](#)
- ["Hardware Page" on page 233](#)

Shutting Down and Restarting a Compute Module

From the **Hardware** page, you can shut down and restart a compute module. You do this to perform service operations that require physically removing a compute module from the system.

A compute module must be in maintenance mode before you shut it down. For information about entering a compute module into maintenance mode, see ["Using Maintenance Mode" on page 239](#).

To shut down a compute module

1. From the **Hardware** page, select a compute module that is in maintenance mode.
2. Click **Shutdown**.
3. Click **Yes** on the **Confirm** window.

When the compute module has been shut down, its state appears as **Maintenance Mode**, and its **Activity** displays as **Shutdown**. At this point, it is safe to [remove the compute module](#).

To restart a compute module

1. From the **Hardware** page, select a stopped compute module.
2. Click **Boot**.
3. Click **Yes** on the **Confirm** window.

After the compute module completes its restart, its state still appears as **Maintenance Mode**, and its **Activity** displays as **Running**.

4. [Remove the compute module from maintenance mode](#).

Related Topics

- ["ztC Endurance Console" on page 223](#)
- ["Hardware Page" on page 233](#)
- ["Using Maintenance Mode" on page 239](#)
- ["Removing and Replacing a Compute Module" on page 107](#)

Volumes Page

The **Volumes** page displays information about logical storage volumes created from the physical devices in the storage modules. To open this page, in the left-hand navigation panel, click **Volumes** under **System**.

The **Volumes** page displays the following columns with information about volumes in the top pane:

- State
- Name
- Disk Synchronization. If a volume is synchronizing, this column displays the percentage complete and the estimated time of completion.

- Size
- Datastores

Click the name of a volume in the top pane of the **Volumes** page to display additional information about the volume in the bottom pane. This information includes the physical members of the volume as well as their states.

You can also display information about volumes using the `snmptable` command; see ["Obtaining System Information with snmptable"](#) on page 261.

Related Topics

- ["Disk Drives" on page 28](#)
- ["ztc Endurance Console" on page 223](#)

Specifying Owner Information

Specify the name and contact information for an administrator or owner of the ztc Endurance system to make this information available for support purposes. This contact information is included in any email sent by e-Alerts.

This contact information is available in the ztc Endurance console and provided in response to Simple Network Management Protocol (SNMP) requests.



Note: The information you specify during Step 1 and Step 2 of the registration portal procedure (see ["Registering the System" on page 243](#)) is automatically supplied as the system owner information on the **Owner Information** page. However, if you have already specified system owner information on the **Owner Information** page and then register your system, the information specified during registration does not overwrite the system owner information.

To specify system owner information

1. In the left-hand navigation panel, click **Owner Information** under **System**.
2. On the **Owner Information** page, supply information in the **Full Name**, **Phone Number**, **Email Address**, and **Site Address** fields.
3. Click **Save**.

Related Topics

- ["ztc Endurance Console" on page 223](#)

Registering the System

Registering a ztc Endurance system:

- Helps Penguin Solutions Customer Service deliver responsive, expedited service, should you contact Penguin Solutions with a potential issue or need a replacement part.
- Registers you for the **Penguin Solutions Customer Service Portal** at <https://support.penguinsolutions.com/csm>, giving you access to technical resources—including Knowledge Base articles, Customer Service publications, and software downloads—that are available only to registered users.

To use these services, it is important to register the system soon after you log in to the ztC Endurance console for the first time or if you are upgrading from ztC Endurance Release 1.0.x.x. However, you can register the system later. You can do so on a system with or without Internet access.



Note: The information you specify during Step 1 and Step 2 of the registration portal procedure is automatically supplied as the system owner information on the **Owner Information** page (see "Specifying Owner Information" on page 243). However, if you have already specified system owner information on the **Owner Information** page and then register your system, the information specified during registration does not overwrite the system owner information.

On a system that does not have Internet access, you need to move a file between the location of the ztC Endurance console (which does not have Internet access) and a location with Internet access. Two possible methods for moving the file follow.

- A USB flash drive—You move a USB flash drive between a management PC (which can connect to the system) and a computer with Internet access.
- A mobile device such as a laptop or smart phone—You move a mobile device between a location where you can log in to the ztC Endurance console and a location with Internet access.



Prerequisite: Before you register the system, read [To complete the registration portal steps](#) to ensure that you have all required information.

To complete the registration portal steps

Step 1: General Information—Enter the following information:

- **First Name and Last Name**
- **Company Email**—Provide the email address of the company that is the final deployment site. Do not provide a personal email address.

You also need to review and accept the **Service Terms**.

Step 2: Location Info—Enter the following information:

- **End User Company Name**—Provide the full name of the company where the system will be deployed.
- **Deployment Shipping Address**—Provide the complete address for replacement-part shipments. Use the address of the company that is the final deployment site. Do not provide a post-office box. Fields are:
 - **Address 1 and Address 2**
 - **City, State, Postal Code, and Country**
 - **Special Instructions** (for example, "always deliver to loading dock 2")

Step 3: Contact Details—Enter the following information:

- **Primary Technical Contact and Secondary Technical Contact**—Provide the names of the technical contacts who will be communicating with your authorized Penguin Solutions service representative.
- **Service Renewal Contact**—Provide the name of the person who is responsible for handling annual service-agreement renewals.

For each contact, enter **First Name, Last Name, Email Address, Desk Phone, and Mobile (optional)**. You can add more contacts later using the **Penguin Solutions Customer Service Portal** at <https://support.penguinsolutions.com/csm>.

After you click **Next** at the bottom of the page, Penguin Solutions verifies the information.

If there is a problem with the information, a **Problem Encountered** pane appears, which describes the problem. Click **Back** to fix the problem, if possible. If a problem still exists, click **Next** to continue, allowing you to download a file that enables you to complete registration. To help resolve the problem and ensure that your account is set up properly, your authorized Penguin Solutions service representative will contact you.

An **Information Verification** page appears, allowing you to review the information. Click **Back** to change any information. Click **Next** to submit the information and complete registration.

Step 4: License Key—For a system with Internet access, check the **License** page of the ztC Endurance console to confirm that the license has been installed. For a system without Internet access, click **Download License** to download the license-key file, which you will install on the ztC Endurance system. Make note of the location where you download the file.

To register a system and acquire a license

On a system with Internet access

1. In the ztC Endurance console, do one of the following:
 - a. Click **License**, under **System**, in the left-hand navigation panel.
 - b. Click **Register for License** in the masthead.
2. For **Online License Registration and Activation**, click **Register Online** to open a new browser tab with the Penguin Solutions registration web portal. Then, complete the [registration web portal steps](#).

At **Step 4**, check the **License** page of the ztC Endurance console to confirm that the license has been installed. If needed, click **Check License Now** next to **Online License Check**. When **STATUS** changes to **License installed**, the license has updated successfully, and registration is complete.

If the license does not update successfully within 5 minutes, click **Download License** in the registration web portal to download the license-key file. Continue with the next step.

3. On the **License** page of the ztC Endurance console, under **Offline License Check and Manual License Installation**, click **Choose File** under **Install an Activated License Key to the System**. Navigate to the location where you saved the file, select the file, and click **Open**.
4. On the **License** page of the ztC Endurance console, click **Upload** to upload the file to the system. If needed, click **Check License Now** next to **Online License Check**. When **STATUS** changes to **License installed**, the license has updated successfully, and registration is complete.

On a system without Internet access

If a system does not have Internet access, you need to move a file between the location of the ztC Endurance console (which does not have Internet access) and a location with Internet access. The following procedure describes one method, though other methods are possible.

On a computer or mobile device with access to the ztC Endurance console

1. If using a management PC, insert a USB flash drive into a USB port.
If using a mobile device, ensure that it has access to the ztC Endurance console.
2. In the ztC Endurance console, click **License**, under **System**, in the left-hand navigation panel.
3. For Step 1, **Offline License Registration via URL File** (beneath the **Offline License Registration and Manual License Installation** bar), click **Download URL File** and save the *register_site_file.html* file to the USB flash drive or mobile device. If using a USB flash drive, remove it.
4. Go to a location with Internet access.

In a location with Internet access

1. If using a USB flash drive, insert it into a USB port of the computer with Internet access.
2. Navigate to the file you saved, and click the file name. A browser opens the file and is redirected to the Penguin Solutions registration web portal. Complete the [registration web portal steps](#).
At **Step 4**, download the permanent license-key file and save it to the USB flash drive or mobile device. If using a USB flash drive, remove it.
3. Return to the location with access to the console.

On a computer or mobile device with access to the ztC Endurance console

1. If using a USB flash drive, insert it into a USB port on the management PC.
If using a mobile device, ensure that it has access to the ztC Endurance console.
2. In the ztC Endurance console, click **License**, under **System**, in the left-hand navigation panel.

3. For Step 2, **Install an Activated License Key to the System** (beneath the **Offline License Registration and Manual License Installation** bar), click **Choose File**. Navigate to the location where you saved the license-key file, select the file, and click **Open**.
4. Click **Upload** to upload the file to the system.

Related Topics

["Logging In to the ztC Endurance Console" on page 226](#)

Configuring Users

Use the **Users** page to add, modify, or remove user accounts on the ztC Endurance system. You can select a user and view the time when the user's password was last updated. An administrator can also use the page to force a selected user to change the user's password on the next login.

To open this page, in the left-hand navigation panel, click **Users** under **Administrative Tools**.

To manage user accounts

To add a new user, click **Add** in the lower pane. On the **Add a User** window, supply the requested information and click **Save**.

To modify an existing user, click the name of a user account and click **Edit**. On the **Edit User** window, modify the information and click **Save**.

To remove an existing user, click the name of a user account and click **Remove**. On the **Confirm** window, click **Yes**.

To view the time when a user last changed the user's password, look at the **Last Password Update Time** column for a selected user. To force a user to change the user's password on the next login, an administrator selects the user and then clicks **Expire Password**.

For more information, see ["Managing User Accounts" on page 249](#).

To sort and locate user accounts

If you have a large number of accounts, you can click a column heading to sort the accounts by parameter. You can sort accounts by **Type**, **Username**, **First Name**, **Last Name**, **Email**, **Role**, or **Last Password Update Time**.

Related Topics

- ["ztC Endurance Console" on page 223](#)

Managing User Accounts

You add, edit, or remove users, specify passwords, and assign user roles to user accounts on the **Users** page in the ztC Endurance console. You can also select a user and view the time when the user's password was last updated, and an administrator can force a selected user to change the user's password on the next login.

User roles are:

- **Administrator:** full system administrator privileges
- **Platform Manager:** system administrator privileges except for adding, removing, and modifying users
- **Read-only:** ability to view but not to change system configuration or to install system software

For the procedures below, begin by opening the **Users** page: in the left-hand navigation panel, select **Users** under **Administrative Tools**.

To add a user account

1. In the lower pane, click **Add**.
2. In the **Role** drop-down window, select **Administrator**, **Platform Manager**, or **Read-only**.
3. Enter values for the **User Name**, **Email Address**, **First Name**, **Last Name**, **Password**, and **Confirm Password** fields. User names may be from 1 to 64 characters long, and must include no white space. Passwords must conform to the "[Password Policy](#)" on [page 228](#) of the system. Click **Save**.

To edit a user account

1. Select the account you want to edit.
2. In the lower pane, click **Edit**.
3. Change the user's information, as necessary. For example, to change a user's role, in the **Role** drop-down window, select **Administrator**, **Platform Manager**, or **Read-only**.
4. Click **Save**.

To force a user to change the user's password

1. Select the user whose password you want to expire.
2. Click **Expire Password**.
3. Click **Yes** in the **Confirm** dialog box.

To remove a user account

1. Select the account to remove.
2. Click **Remove** in the lower pane.
3. Click **Yes** in the **Confirm** dialog box.

Notes:



1. You cannot delete the default **admin** account if it is the only administrator account, although you should change its name and password by editing the account.
2. You must specify an email address for each user account, including **admin**, to enable the forgot-password feature. If a user account does not include an email address, and the user clicks the **Forgot Password?** link on the console login page, the system sends an email to *user@example.com*.

Related Topics

- ["ztC Endurance Console" on page 223](#)
- ["Configuring Users" on page 248](#)

Alert History Page

The **Alert History** page displays messages about events on the ztC Endurance system. To open this page, in the left-hand navigation panel, click **Alert History** under **Alerts & Logs**.

Note: Support notification alerts, e-Alerts, and SNMP traps are generated only when you enable them in the ztC Endurance console. For information, see:



- ["Configuring Remote Support Settings" on page 271](#)
- ["Configuring e-Alerts" on page 253](#)
- ["Configuring SNMP Settings" on page 254](#)

To view alert information, scroll through the alerts, which are, by default, listed in reverse chronological order. On the upper pane, click an alert to display the following information in the lower pane:

- The date and time the alert occurred
- Information about the problem and resolution (if available)
- Whether a **Support Notification**, **e-Alert**, or **SNMP Trap** was sent for this alert

On the right side of the upper pane, click the arrow to display more detailed information about the alert. Click it again to hide the detailed information.

You can also display alert information using `snmptable`; see "[Obtaining System Information with snmptable](#)" on page 261.)

To remove an alert, select it and click **Remove**.

To remove all alerts, click **Purge All**.



Note: You can remove or purge only those alerts that have been resolved and informational alerts. Outstanding alerts remain in the list and on the **Dashboard** page until you resolve them.

Related Topics

- "[ztC Endurance Console](#)" on page 223

Support Logs Page

The **Support Logs** page enables you to generate diagnostic files, which include the ztC Endurance system's log files and configuration information at a particular moment in time. This information enables Penguin Solutions Customer Service to resolve an issue with the system.

You can click the **Support Site** link in the top-right side of the page to go to the **Penguin Solutions Customer Service Portal**.

For additional information, see:

- "[Creating a Diagnostic File](#)" on page 252
- "[Deleting a Diagnostic File](#)" on page 252

Related Topics

- "[ztC Endurance Console](#)" on page 223

Creating a Diagnostic File

Diagnostic files provide the ztC Endurance system's log files and configuration information at a particular moment in time. You create a diagnostic file to help Penguin Solutions Customer Service resolve issues with the system. You can also download it.



Note: Automated Uptime Layer with Smart Exchange software allocates a fixed amount of storage space for diagnostic files. If a diagnostic file cannot be generated due to insufficient space, the system deletes previously created files.

To create diagnostic files

1. In the left-hand navigation panel, click **Support Logs** under **Alerts & Logs**.
2. On the **Support Logs** page, click **Generate Diagnostic File**.

After the diagnostic file has finished generating (as indicated by **complete** appearing in the **Status** column), you can download the file.

To download a diagnostic file

1. In the left-hand navigation panel, click **Support Logs** under **Alerts & Logs**.
2. On the **Support Logs** page, click anywhere in the row of the diagnostic file that you want to download. When a drop-down menu appears, click **Download** (↓).

Related Topics

["ztC Endurance Console" on page 223](#)

Deleting a Diagnostic File

Delete a diagnostic file from the ztC Endurance system.

To delete a diagnostic file

1. In the left-hand navigation panel, click **Support Logs** under **Alerts & Logs**.
2. On the **Support Logs** page, click anywhere in the row of the diagnostic file that you want to delete. When a drop-down menu appears, click **Delete**.



Note: The drop-down menu does not appear while a diagnostic file is still generating.

Related Topics

- ["ztC Endurance Console" on page 223](#)

Configuring e-Alerts

Configuring email notifications (e-Alerts) enables the ztC Endurance system to send email to the configured list of recipients whenever an alert is generated or resolved. An e-Alert is sent every time an alert changes its state.



Prerequisite: In order for e-Alerts to function properly, you must configure the mail server. See ["Configuring the Mail Server"](#) on page 232.

To enable e-Alerts

1. In the left-hand navigation panel, click **e-Alerts** under **Notification**.
2. On the **e-Alerts** page, click the **Enable e-Alerts** box. The **List of Recipients** setting appears. Enable e-Alert delivery by specifying a valid sender's email address in the **List of Recipients** field. Specify email addresses for additional recipients on separate lines.

Any email address that the SMTP server accepts is sufficient.

3. Click **Save**.



Notice: If you notice that delivery of e-Alerts seems delayed and you see the message `Message submission rate for this client has exceeded the configured limit` in the `sra-mgmt` log, the number of e-Alerts sent in a short period of time may have exceeded the email limits set in your mail server. Contact your email administrator if you need to increase the mail server's email limits.



Note: When you enable or update the e-Alert configuration, generate a test alert to confirm that the email messages are received.

To generate a test alert

Click **Generate Test Alert**. The Automated Uptime Layer with Smart Exchange software generates a test alert and sends a sample email with the subject "Test Alert" to all email recipients; SNMP sends traps to recipients of SNMP traps, if configured (see "[Configuring SNMP Settings](#)" on page 254); and Support Configuration sends a notification to your authorized Penguin Solutions service representative, if configured (see "[Configuring Remote Support Settings](#)" on page 271). A few minutes later, the software clears the test alert and sends an email notifying all email recipients that the alert has been cleared. View the **Alert History** page (see "[Alert History Page](#)" on page 250) for delivery status.



Notice: If the list of recipients changes immediately after a test alert is being generated, the recipient of the test alert may not receive the follow-up email stating that the alert has been cleared. To avoid this situation, do not change the list of recipients until after the recipient receives the follow-up email.

Related Topics

- "[ztC Endurance Console](#)" on page 223

Managing SNMP

Simple Network Management Protocol (SNMP) is a standard protocol for receiving alarms, sending traps, and monitoring system status. SNMP draws upon system-defining information that is stored in hierarchically configured management information bases (MIBs).

To configure a system to use SNMP, see "[Configuring SNMP Settings](#)" on page 254.

For information on using the `snmptable` command to obtain information about the system, specifically information about alerts, hardware components, and volumes, see "[Obtaining System Information with snmptable](#)" on page 261.

You can download a copy of the MIB file from the **Penguin Solutions Customer Service Portal** at <https://support.penguinsolutions.com/csm>. For instructions for downloading software, see "[Getting Help](#)" on page 299.

Related Topics

- "[ztC Endurance Console](#)" on page 223

Configuring SNMP Settings

Configure Simple Network Management Protocol (SNMP) settings for the ztC Endurance system to allow SNMP management applications to remotely monitor your systems. (SNMP information pertains

to systems as well as many system components, such as compute modules, storage modules, disks, and so on.) You can enable SNMP requests and SNMP traps:

- **SNMP request**—A request sent to the system to retrieve the values of objects listed in the Management Information Bases (MIBs) supported by the Automated Uptime Layer with Smart Exchange software. These MIBs include a system-specific MIB that is a collection of objects describing the ztC Endurance system. You can download a copy of the MIB file from the **Penguin Solutions Customer Service Portal** at <https://support.penguinsolutions.com/csm>. For instructions for downloading software, see "Getting Help" on page 299.
- **SNMP trap**—A message initiated by one of the components in the ztC Endurance system after an event such as an alert that is then sent to an identified list of recipients (typically, a network management station (NMS)).

Managing Firewall Settings

You may need to modify some firewalls in order to communicate SNMP requests or traps from or to an NMS.

- When you installed the ztC Endurance software, your organization's firewall was automatically configured to open port 161 (Get/Walk) and 162 (Traps) for inbound and outbound traffic to the virtual machine (VM). No user action is needed.
- No configuration of the ESXi host firewall is needed when communicating with a VM running on the host.
- If there is a firewall between the network that the ztC Endurance system is on and the location of the NMS, you may need to update your organization's firewall. Contact your network administrator about modifying the firewall.

Follow the appropriate procedure to enable SNMP requests or traps.

To enable SNMP requests

To enable SNMP requests, perform one of the following actions:

- Enable SNMP requests from the **SNMP Configuration** page of the ztC Endurance console:
 - Add an SNMPv3 user who can enable SNMPv3 requests and who has read-only access to the full MIB in the ztC Endurance system.
 - Configure access control for SNMPv1 and SNMPv2 requests, where you allow no users (**Restricted**) or any user using the default public community (**Unrestricted**) to send requests.
- Customize SNMP request functionality by editing `snmpd.conf` files. You can customize access control for SNMPv1 requests and SNMPv2 requests. You can also customize the list of users for SNMPv3 requests. For information, see [To customize SNMP request functionality](#) (below).

To enable SNMP requests from the SNMP Configuration page

1. In the left-hand navigation panel, click **SNMP Configuration** under **Notification**.
2. On the **SNMP Configuration** page, activate the check box next to **Enable SNMP Requests**.
3. The **List of Users for SNMP Requests (version 3)** and a read-only display of the `snmpd.conf` file appear.

If a username appears below the **List of Users for SNMP Requests (version 3)**, the user's security level is displayed. The user has read-only access to the full MIB.

If a username does not appear, you can add an SNMPv3 user.



Notice: Always use this procedure to add or remove SNMPv3 users. Do not edit the `/etc/snmp/snmpd.conf` and `/var/lib/net-snmp/snmpd.conf` files for this purpose.

To add an SNMPv3 user

- a. Click the  **Add** button, which opens the **Add a User** wizard.
- b. Enter values for the following:

Username—The name of a user who has access to the SNMPv3 agent. The name must be unique.

Security Level—The user's security level. Valid values are:

- **No Authentication and No Privacy**: No security is applied to messages; messages are not authenticated or encrypted.
- **Authentication and No Privacy**: Messages are authenticated but not encrypted. You must enter values for **Authentication Type** and **Authentication Password**.
- **Authentication and Privacy**: Messages are authenticated and encrypted. You must enter values for **Authentication Type**, **Authentication Password**, **Encryption Type**, and **Encryption Password**.

When the security level includes authentication or privacy, the following fields appear:

Authentication Type—The user's type of authentication. Valid values are:

- **MD5**: Configure the message digest algorithm (MD5) as the user's authentication type.
- **SHA**: Configure the secure hash algorithm (SHA) as the user's authentication type.

Authentication Password—The user's required password, which is used to generate the secret authentication key. The password must be a minimum of eight characters and cannot be the same as the username.

Encryption Type—The user's type of encryption. Valid values are:

- **AES**: Configure the advanced encryption standard (AES) as the user's encryption type.

- **DES:** Configure the data encryption standard (DES) as the user's encryption type.

Encryption Password—The user's required password, which is used to generate the secret encryption key. The password must be a minimum of eight characters and cannot be the same as the username.

- c. Click **Save** to save the changes.
1. Select an access option:
 - Restricted** (the default)—Prevents users from sending SNMPv1 requests and SNMPv2 requests.
 - Unrestricted**—Allows any user using the default public community to send SNMPv1 requests and SNMPv2 requests.
 - Customized** (available when `snmpd.conf` has been manually edited by a user; see [To customize SNMP request functionality](#), below)—Allows customized access.
 2. Click **Save**. (Or click **Cancel** to restore the previously saved values.)

To customize SNMP request functionality by editing `snmpd.conf` files

Customize SNMP request functionality by editing `snmpd.conf` files.

Customize access control for SNMPv1 requests and SNMPv2 requests by editing the `/etc/snmp/snmpd.conf` file:

1. Log in to the host.
2. Manually edit the standard `/etc/snmp/snmpd.conf` file.
3. Save the file.



Notice: The system-management software automatically restarts **snmpd** when it detects that **snmpd.conf** has changed; do not manually restart **snmpd**.

To enable SNMP traps

Notes:



1. When you add a recipient for **SNMP Traps (version 3)**, you need to confirm that the engine ID of the trap user on the recipient server is 0x80001370017F000001.
2. When you enable or modify the SNMP trap settings, generate a test alert to confirm that traps are received.

1. In the left-hand navigation panel, click **SNMP Configuration** under **Notification**.
2. On the **SNMP Configuration** page, activate the check box next to **Enable SNMP Traps**.
3. Type the name of the SNMP **Community**, or keep the default (**public**).
4. Below the **List of Recipients of SNMP Traps (version 3)** is a list of the trap users, and the IP address of the recipient server where the trap user exists. The ztC Endurance system sends SNMPv3 traps to the trap user on the recipient server. Add a recipient, if necessary. Note that the system supports only one trap-recipient user.

To add a recipient

- a. Click the  **Add** button, which opens the **Add a Recipient** wizard.
- b. Enter values for the following:

Recipient Address—The host name or the IPv4 address of the recipient server.

Username—The name of a trap user on the recipient server. The name must be unique for the recipient.

Security Level—The user's security level. Valid values are:

- **No Authentication and No Privacy**: No security is applied to messages; messages are not authenticated or encrypted.
- **Authentication and No Privacy**: Messages are authenticated, but not encrypted. You must enter values for **Authentication Type** and **Authentication Password**.
- **Authentication and Privacy**: Messages are authenticated and encrypted. You must enter values for **Authentication Type**, **Authentication Password**, **Encryption Type**, and **Encryption Password**.

When the security level includes authentication or privacy, the following fields appear:

Authentication Type—The user's type of authentication. Valid values are:

- **MD5**: Configure the message digest algorithm (MD5) as the user's authentication type.
- **SHA**: Configure the secure hash algorithm (SHA) as the user's authentication type.

Authentication Password—The user's required password, which is used to generate the secret authentication key. The password must be a minimum of eight characters and cannot be the same as the username.

Encryption Type—The user's type of encryption. Valid values are:

- **AES:** Configure the advanced encryption standard (AES) as the user's encryption type.
- **DES:** Configure the data encryption standard (DES) as the user's encryption type.

Encryption Password—The user's required password, which is used to generate the secret encryption key. The password must be a minimum of eight characters and cannot be the same as the username.

- c. Click **Save** to save the changes.
5. Click **Save**. (Or click **Cancel** to restore the previously saved values.)
6. Click the **Generate Test Alert** button at the bottom of the configuration window.

The Automated Uptime Layer with Smart Exchange software generates a test alert and SNMP sends traps to recipients of SNMP traps; e-Alerts send a sample email with the subject "Test Alert" to all email recipients of e-Alerts, if configured (see ["Configuring e-Alerts" on page 253](#)); and Support Configuration sends a notification to Penguin Solutions Customer Service, if configured (see ["Configuring Remote Support Settings" on page 271](#)). Watch the Alert History log (see ["Alert History Page" on page 250](#)) for delivery status.

Related Topics

- ["ztC Endurance Console" on page 223](#)
- ["Managing SNMP" on page 254](#)

Obtaining System Information with snmptable

You can issue the `snmptable` command to obtain information about the system, specifically information about alerts, modules, and volumes.





















Note: The `snmptable` examples shown in this topic use the `-v2C` option, but the `-v1` or `-v3` option is also valid.



















To display alert information

To display information about alerts, issue the following command:

```
snmptable -m +/usr/share/snmp/mibs/STRATUS-ZTC-ENDURANCE-MIB.txt -v2c -c public localhost zenAlertTable
```

The command output displays the following:

Field	Description												
zenAlertIndex	The alert number.												
zenAlertSeverity	<p>The alert severity (see zenAlertSeverityNum for numerical value). Their values, as well as their corresponding symbols in the ztC Endurance console, are:</p> <table> <tr> <td>clear</td> <td></td> </tr> <tr> <td>informational</td> <td></td> </tr> <tr> <td>minor</td> <td></td> </tr> <tr> <td>major</td> <td></td> </tr> <tr> <td>serious</td> <td></td> </tr> <tr> <td>critical</td> <td></td> </tr> </table>	clear		informational		minor		major		serious		critical	
clear													
informational													
minor													
major													
serious													
critical													
zenAlertType	<p>The type of alert. Examples are:</p> <ul style="list-style-type: none"> • Network_noLink • Cru_simplex 												
zenAlertSource	<p>The source of the alert. Examples are:</p> <ul style="list-style-type: none"> • io_module_A:slot6 • io_module_B:io_module_B 												
zenAlertDateTime	<p>The date and time of the alert, in the format <i>yyyy-mm-dd hh:mm:ss</i>, where <i>yyyy</i> is year, <i>mm</i> is month, <i>dd</i> is date, <i>hh</i> is hour, <i>mm</i> is minute, and <i>ss</i> is second (for example, 2023-11-03 23:49:45).</p>												

Field	Description																		
zenAlertCallHomeSent	If true, Call Home was sent; if false, it was not sent.																		
zenAlertEAlertSent	If true, e-Alert was sent; if false, it was not sent.																		
zenAlertSNMPTrapSent	If true, SNMP trap was sent; if false, it was not sent.																		
zenAlertInformation	Information about the alert. Examples are: <ul style="list-style-type: none"> • CRU with device path IO slot B/6 simplex • Network interface IO slot A/6 on IO module A has no link/carrier. 																		
zenAlertSNMPTrapOID	SNMP trap object identifier (OID). An example is SNMPv2-SMI::zeroDotZero (zeroDotZero is how SNMP describes an OID of zero).																		
zenAlertSeverityNum	zenAlertSeverity number. Their values, as well as their corresponding symbols in the ztC Endurance console, are: <table> <tbody> <tr> <td>0</td> <td>Clear</td> <td></td> </tr> <tr> <td>1</td> <td>Informational</td> <td></td> </tr> <tr> <td>2</td> <td>Minor</td> <td></td> </tr> <tr> <td>3</td> <td>Major</td> <td></td> </tr> <tr> <td>4</td> <td>Serious</td> <td></td> </tr> <tr> <td>5</td> <td>Critical</td> <td></td> </tr> </tbody> </table>	0	Clear		1	Informational		2	Minor		3	Major		4	Serious		5	Critical	
0	Clear																		
1	Informational																		
2	Minor																		
3	Major																		
4	Serious																		
5	Critical																		

To display volume information

To display volume information, issue the following command:

```
snmptable -m +/usr/share/snmp/mibs/STRATUS-ZTC-ENDURANCE-MIB.txt
-v2c -c public localhost zenMirrorTable
```

The command output displays the following:

Field	Description
zenMirrorIndex	An incrementing number (1, 2, etc.) to indicate the volume whose information is displayed.
zenMirrorName	The mirror name (mpm1 through mpm6).
zenMirrorUUID	The unique ID of the mirror (for example, 325d706d:2840a200:09c6d390:6424c6e8).
zenMirrorSizeGB	The volume size in gigabytes (for example, 1788).
zenMirrorResync	If resync is running, the current resync status.
zenMirrorDiskName1	The disk name for one of the mirror disks (for example, vmhba3:C0:T0:L0).
zenMirrorDiskState1	The disk state for one of the mirror disks (for example, in_sync).
zenMirrorDiskName2	The disk name for the other mirror member.
zenMirrorDiskState2	The disk state for the other mirror member.

Related Topics

- ["Alert History Page" on page 250](#)
- ["Volumes Page" on page 242](#)
- ["ztC Endurance Console" on page 223](#)

Configuring OPC Settings

Configure Open Platform Communication (OPC) settings to enable OPC server functionality, which publishes ztC Endurance system performance data for an OPC client to receive and display. This

allows you to monitor the ztC Endurance system alongside other industrial equipment.

In order to use OPC functionality, you must install OPC client software (of your choice) on a separate computer and then configure the OPC client (see ["To install and configure an OPC client" on page 266](#)). The OPC client must be configured to receive data from the port on the ztC Endurance system that you configure for OPC. The default port is 4840, but you can specify another port number.

To configure OPC settings

1. In the left-hand navigation panel, click **OPC Configuration** under **Notification**.
2. On the **OPC Configuration** page, activate the check box next to **Enable OPC Server**.
3. The default port number is **4840**. If necessary, specify another number.
4. Activate either or both of the following check boxes, as appropriate for your system:
 - **Allow anonymous OPC client connections:** OPC clients do not need to provide a username and password when connecting to the OPC server on the ztC Endurance system. (When the check box is not activated, OPC clients must provide a username and password.)
 - **Allow OPC client connections using usernames and passwords configured from Users:** OPC clients can connect to the OPC server on the ztC Endurance system with the same username and password used to log in to the ztC Endurance console. (When the check box is not activated, OPC clients cannot log in to the OPC server using local-user account usernames and passwords, as specified on the **Users** page. See ["Managing User Accounts" on page 249](#).)
5. Click **Save**. (Or click **Cancel** to restore the previously-saved values.)

To install and configure an OPC client

You must install OPC client software and configure an OPC client on a separate computer. You can choose OPC client software from the many versions that exist in the marketplace. The following procedure describes how to install and configure an OPC client using UaExpert® software from Unified Automation.

Installing and Configuring an OPC Client Using UaExpert Software



Note: In addition to reading the following procedure, follow instructions with the UaExpert software.

1. Download and install the Windows version of the UaExpert software. See <https://www.unified-automation.com/products/development-tools/uaexpert.html>.
2. If starting UaExpert software for the first time, follow the instructions with the software for an initial start-up.
3. Run the UaExpert software.

The **Unified Automation UaExpert - The OPC Unified Architecture Client - NewProject** main window opens.

4. In the menu bar, click **Server** and select **Add**. The **Add Server** dialog box appears.
5. Click the **Advanced** tab.
6. In the **Endpoint Url** box, enter the URL of the endpoint, which is the ztC Endurance system's cluster IP address (for example, **opc.tcp://tcp_cluster_ip_address:4840/**).
7. For **Security Settings**, select **None** for both **Security Policy** and **Message Security Mode**.
8. For **Authentication Settings**, select one of the following, as required for your configuration:
 - **Anonymous:** Select if you activated the check box for allowing anonymous OPC client connections.
 - **Username and Password:** Enter values if you activated the check box for allowing OPC client connections using usernames and passwords. The username and password you enter must be identical to the username and password that you add for a read-only user on the ztC Endurance system for

OPC access. See ["Managing User Accounts" on page 249](#) for information on adding a user to the ztC Endurance system.

9. Click **OK** to close the **Add Server** dialog box.

The main window reappears. In the left panel, the name of the server appears in the **Project** box, under **Servers**.

10. Select the new server and then click the connect button, which appears in the tools bar to the right of the minus-sign icon.

When the client connects successfully to the server, the **Address Spaces** box of the main window displays the end point of the server.

In the **Address Spaces** box, you can click the top level to expand and explore the available data values. In the **Attributes** box, the **Value** column displays the current value of the selected item.

Related Topics

- ["Displaying OPC Output" on page 267](#)
- ["ztC Endurance Console" on page 223](#)
- ["Using the ztC Endurance Console" on page 223](#)

Displaying OPC Output

After you have enabled OPC server functionality on the ztC Endurance system, an OPC client, located on a computer that is not the ztC Endurance system, can publish the system's performance data. The data is divided into address spaces, where each address space is divided into sub-objects that contain several data items. The OPC server functionality on the ztC Endurance system passes values for the data items to the OPC client, which then displays the data.

This topic describes how to display a ztC Endurance system's basic inventory and health information using an OPC client created with UaExpert[®] software from Unified Automation.

For more information about navigating the OPC client, click the **Help** tab in the navigation menu at the top of the client window.

To display OPC output

1. On the computer where you have created an OPC client, open the client.
2. In the (left) **Project** panel, click **Project**, **Servers**, and then **ztC OPC Server**.

After you select **ztC OPC Server**, the **Address Space** panel under **Project** displays the **Root** hierarchy.

3. In the **Address Space** panel, under **Root**, click **Objects**. Under **Objects**, you can select **Server** and **ztCEndurance**. Each physical component of the system is represented by a data item in the panel; click the data item to check the component's status. The **Attributes** panel on the right side of the window displays the value of the selected data item.

The following tables describe some of the data items that can be viewed on the OPC client.

Server

For information about the compute module that is currently running the OPC server, click **Server** and then **ServerStatus** to view the **BuildInfo** sub-object.

The **BuildInfo** sub-object displays values for the following data items:

Data Items	Description
ProductUrl	Displays http://www.stratus.com/ .
ManufacturerName	Displays Stratus Technologies Ireland, Ltd.
ProductName	Displays the product name of the hardware (ztC Endurance).
SoftwareVersion	Displays the version number of the Automated Uptime Layer with Smart Exchange software.
BuildNumber	Displays the Automated Uptime Layer with Smart Exchange software build number.
BuildDate	Displays the date of the Automated Uptime Layer with Smart Exchange software build.

For additional information about the **Server** object, see *Part 5: Information Model* of the *OPC Unified Architecture Specification*, which is available at opcfoundation.org.

ztCEndurance

The **ztCEndurance** object divides the address space according to each of the physical components of the connected ztC Endurance system. The sub-objects are as follows: **Compute Modules, I/O Modules, Mirrors, Power Supply Units, Storage Modules** and **System**. These sub-objects can be opened to display their components.

For example, the data item **ComputeModuleA** expands to display the following data items:

Data Items	Description
BMCIPv4AddressA	Displays the IP address of BMC A. Data type: string
BMCIPv4AddressB	Displays the IP address of BMC B. Data type: string
Healthy	Indicates whether the module is healthy: <i>true</i> indicates the module is present, running green-checked, and is not in maintenance mode; <i>false</i> indicates that the module is not present, is not running green-checked, and/or is in maintenance mode. Data type: Boolean
Present	Indicates whether the module is present; <i>true</i> or <i>false</i> value. Data type: Boolean
State	Indicates whether the module is online. Example value: <i>ONLINE/ACTIVE</i> . Data type: string

Additional Data Items

The following table lists data items not found in the previous example, but that appear in other sub-objects under the **ztCEndurance** tab.

Data Items	Description
LinkSpeed	Numeric value that indicates the link speed of the management PC. Data type: Int64
LinkUp	Indicates that the network wire is connected and communicating; <i>true</i> or <i>false</i> value. Data type: Boolean
EnduranceRemaining	Percentage value that indicates how much of the system's predicted life span remains. Data type: UInt64

System

The data items for the system provide high-level status information as well as information about access methods for the overall system.

Data Items	Description
Healthy	Indicates the system health with <i>true</i> or <i>false</i> value. Data type: Boolean
Model	Displays the system model name. Data type: string
OutstandingSeverityLevel	Corresponds to the overall system status icon on the login page. Data type: UInt32
StratusManagementURL	Displays the HTTPS URL of the ztC Endurance system. Data type: string
SecureManagementURL	Displays the HTTPS URL for the ztC Endurance console. Data type: string

Related Topics

- ["Configuring OPC Settings" on page 264](#)

Configuring Remote Support Settings

When you log on to the ztC Endurance system for the first time, configure support configuration settings that enable the ztC Endurance system to send support notifications (alerts) to Penguin Solutions Customer Service via the Active Service Network (ASN) when an event requires attention.

To configure support configuration settings



Note: When you enable or modify settings for **Enable Support Notifications**, generate a test alert to confirm that Penguin Solutions Customer Service can receive system health messages from your system.

1. In the left-hand navigation panel, click **Support Configuration** under **Remote Support**.
2. On the **Support Configuration** page, modify the settings, as appropriate for your system:



Notice: If you plan to enable remote support access, the [ASNConnect by BeyondTrust](#) software must already be installed. The **Enable Remote Support Access** option will be grayed out if it is not installed.

- **Enable Remote Support Access** allows Penguin Solutions Customer Service to remotely connect to the ztC Endurance system for troubleshooting purposes. You can enable and then disable this setting, as needed.
- **Enable Support Notifications** allows the ztC Endurance system to send health and status notifications to Penguin Solutions Customer Service. **Enable Support Notifications** sends an alert for any event that requires attention. You can also select **Enable Periodic Reporting** to send a periodic "heartbeat" call-home message to Penguin Solutions Customer Service.



Note: To allow Penguin Solutions Customer Service to monitor your system for failed ASN heartbeat alarms, you must enable heartbeats in the **Penguin Solutions Customer Service Portal**. See "To configure ASN "heartbeat" alarms" on page 274.

3. Click **Save** (or click **Cancel** to restore the previously saved values).
4. Configure your organization's firewall to allow support messages.

To configure your firewall to allow support messages

Use the following information as needed to configure your organization's firewall to allow communication with Penguin Solutions Customer Service:

Message Type: Call-Home and Licensing
Protocol: TCP
Port: 443
Stratus support server address: *.stratus.com

Message Type: Support Diagnostics
Protocol: TCP
Port: 443
Stratus support server address: *.stratus.com

Message Type: ASNConnect
Protocol: TCP
Port: 443, Default proxy port: 3128 (You can change the default proxy port number.)
Stratus support server address: *.asnconnect.stratus.com

To enable SNMP management systems to receive alerts and send traps to the ztC Endurance system, configure the firewall for the following:

Message Type: SNMP
Protocol: SNMP
Port: 161 (Get/Walk) 162 (Traps)

5. Generate a test alert.

To generate a test alert

Click **Generate Test Alert**. The system generates a test alert and Support Configuration sends a notification to Penguin Solutions Customer Service; e-Alerts send a sample email with the subject "Test Alert" to all email recipients of e-Alerts, if configured (see ["Configuring e-Alerts" on page 253](#)); and SNMP sends traps to recipients of SNMP traps, if configured (see ["Configuring SNMP Settings" on page 254](#)). View the **Alert History** page (see ["Alert History Page" on page 250](#)) for delivery status. A subsequent alert is generated if the support notification fails.

To configure ASN "heartbeat" alarms

1. On the **Support Configuration** page, ensure that **Enable Support Notifications** is selected, and select **Enable Periodic Reporting**. Click **Save**.
2. Log in to the **Penguin Solutions Customer Service Portal** and open the ztC Endurance asset that you want to enable for periodic ASN "heartbeat" alarms. Click the **Service Network Configuration** link.
3. On the **Service Network Configuration** page, select **Enable Heartbeat**. For **Heartbeat Interval**, select **Days** and **1**, then select **Default Heartbeat Grace Period**. Click **Save Configuration**.

Related Topics

- ["ztC Endurance Console" on page 223](#)
- ["Getting Help" on page 299](#)

Configuring Internet Proxy Settings

Configure proxy settings for the ztC Endurance system if your organization requires a proxy server to access the Internet and you have a service agreement with Penguin Solutions or another authorized ztC Endurance service representative.

A proxy server provides a secure bridge between the ztC Endurance system and the Internet. Automated Uptime Layer with Smart Exchange software uses proxy server information for only outbound HTTP traffic related to support notification messaging and remote support access features.

To configure Internet proxy settings

1. In the left-hand navigation panel, click **Proxy Configuration** under **Remote Support**.
2. On the **Proxy Configuration** page, click the **Enable Proxy** box to enable proxy service.
3. For **Scheme**, select either **https** or **http**.
4. In the **Proxy Server** box, type the fully-qualified proxy server host name or IP address.
5. In the **Port Number** box, type the port number if it is different from the default number (3128).
6. If the proxy server requires authentication, click the **Enable Authentication** box and type the **Username** and **Password**.

If you do not type a password, the previous password continues to be required. If the previous password was empty and you do not enter a new password, the password remains empty.

7. Click **Save** (or click **Cancel** to restore the previously saved values).

Related Topics

- ["ztC Endurance Console" on page 223](#)

Upgrade Kits Page

The ztC Endurance **Upgrade Kits** page enables you to upload and manage upgrade kits. Use this page to upgrade the system to newer versions of the Automated Uptime Layer with Smart Exchange software.

For complete instructions on downloading upgrade kits from the **Penguin Solutions Customer Service Portal** and installing them on the system, see ["Upgrading the System Software" on page 191](#).

The **Upgrade Kits** page supports the following functions:

- **Qualify** – When an upgrade kit in the **Ready** state is selected, the **Qualify** button verifies that no version conflicts exist, and that the system is in a healthy state for the upgrade to start. If qualification fails, resolve the issue described in the error message.
- **Upgrade** – When an upgrade kit in the **Ready** state is selected, the **Upgrade** button starts the upgrade process.
- **Delete** – The **Delete** button deletes the selected upgrade kit from the system.
- **Add** – The **Add** button loads an upgrade kit into the **Upgrade Kits** page so that you can apply the upgrade. Before adding an upgrade kit file, you must first download it from the **Penguin Solutions Customer Service Portal** to a local system.

Upgrade Kit States

The left column of the **Upgrade Kits** page displays the state of each kit file that has been uploaded to the system. Possible kit states are as follows:

- **Ready** – The kit is ready to apply.
- **Applied** – The kit has been successfully applied.
- **Apply in progress** – The kit is being applied. This state also displays the status of the host, compute module A, and compute module B.
- **Validating** – The kit checksum is being verified to determine if the kit file was corrupted.
- **Unsupported** – The kit is older than the version currently running on the system. The **Upgrade** button is unavailable for kits that are unsupported, because the system does not support installing older versions.
- **Broken** – The checksum verification failed.

Related Topics

["Upgrading the System Software" on page 191](#)

["ztC Endurance Console" on page 223](#)

["Using the ztC Endurance Console" on page 223](#)

10

Chapter 10: Overview of the BMC Web Console

The BMC Web console is a Web-based interface that allows system administrators and authorized users to manage aspects of the ztC Endurance system. The BMC Web console supports the following capabilities for the user:

- Remote power control
- Remote keyboard/video/mouse (KVM)
- Remote media
- Passive examination of logs and sensors for diagnostic purposes



Note: Each BMC only provides information available to its own compute module. You must query both BMCs to obtain all information.

Related Topics

- ["Prerequisites for Using the BMC Web Console" on page 277](#)
- ["Connecting to the BMC Web Console" on page 278](#)
- ["Logging In to the BMC Web Console" on page 279](#)
- ["Accessing Documentation from the BMC Web Console" on page 280](#)
- ["Configuring DNS Settings in the BMC Web Console" on page 280](#)
- ["Unsupported BMC Web Console Features" on page 281](#)

Prerequisites for Using the BMC Web Console

Before connecting to the BMC Web console, make sure your management PC adheres to the following requirements:

Required Browser Settings

- Allow pop-ups from this site
- Allow file downloads from this site
- Enable JavaScript for this site (any JavaScript release can be used)
- Enable cookies for this site

The BMC Web console supports the following browsers:

- Firefox® Version 2.0 and above (Linux® and Windows®)
- Chrome™ Version 2.0 and above (Windows)
- Microsoft® Edge Version 105 and above (Windows)

Additional Requirements

For remote media connections, reduce the link speed to 100 Mbps in the network interface of the system that is hosting the remote media.

Related Topics

- ["Overview of the BMC Web Console" on page 277](#)

Connecting to the BMC Web Console

You connect to the BMC Web console by entering the IP address of the BMC Web console into a supported Web browser. For more information on supported browsers, see ["Prerequisites for Using the BMC Web Console" on page 277](#). You can obtain the IP address from the ztC Endurance console. If the ztC Endurance console is not running, you can obtain the IP address from the BIOS setup utility.

To obtain the BMC Web console IP address from the ztC Endurance console

1. [Log in to the ztC Endurance console](#).
2. In the left-hand navigation panel, click **Hardware** under **System**.
3. Under **Hardware**, select the correct compute module from the list.
4. Click the **BMC** tab in the bottom pane to display the IP addresses.
5. Click the IP address of the BMC Web console to which you want to connect.

To obtain the BMC Web console IP address from the BIOS setup utility

1. [Enter the BIOS setup utility](#).
2. Click **Server Mgmt**.

3. Under **Server Mgmt**, click **BMC Network Configuration**.
4. Scroll to **LAN Channel 1** or **LAN Channel 8** and locate **Station IP Address**. Copy the IP address, paste it into your Web browser, and hit **Enter** to connect to the BMC Web console.

Next Steps

After you connect to the BMC Web console IP address, log in as described in "[Logging In to the BMC Web Console](#)" on page 279.

Related Topics

- "[ztC Endurance Console](#)" on page 223
- "[Overview of the BMC Web Console](#)" on page 277

Logging In to the BMC Web Console

After you [connect to the BMC Web console](#), log in to it by entering an authorized username and password on the login page. When logging in to the BMC Web console for the first time, use the default credentials:

Username: **admin**

Password: **admin**



Warning: After system installation, change the **admin** password only as described in "[Changing Passwords on a ztC Endurance System](#)" on page 217. Otherwise, a system failure may occur.



Notice: Prior to system installation, the BMC Web console username and password are set to the default **admin**. During the installation, you are asked to provide a new password for the **admin** account. After the installation is complete, you must create a separate user account for personal use. Passwords must be 8-16 characters. For more information, see "[To create a new user account](#)" on page 280

To log in to the BMC Web console

1. Next to **Username** on the BMC login page, type your username (**admin**, if this is your first login).
2. Next to **Password**, type your password (**admin**, if this is your first login).
3. Click **Sign me in**.

Note:



While multiple users can be logged in to the BMC Web console, only one user can connect to the H5Viewer (the KVM) at a time. If a new user attempts to log in, the current user receives a message in the H5Viewer asking permission to give the new user access. If the current user does not respond, the new user is automatically granted access.

To create a new user account

1. From the BMC Web Console dashboard, click **Settings**.
2. Under **Settings**, click **User Management**.
3. Select the desired channel from the drop-down button at the top of the page. Click any of the available slots displayed.
4. Enter the new user's information and click **Save** when finished.

Related Topics

- ["Overview of the BMC Web Console" on page 277](#)

Accessing Documentation from the BMC Web Console

The BMC Web console contains a **Help** button () located in the top right corner of each page. When you click the Help button, information about the page appears. Click the Help button again to hide the information.

Related Topics

- ["Overview of the BMC Web Console" on page 277](#)

Configuring DNS Settings in the BMC Web Console

Configure Domain Name System (DNS) settings in the BMC Web console to register your system's name with your DNS server while in DHCP mode. This mode is called Dynamic DNS (DDNS).

The BMC Web console has three DDNS configuration options:

- **nsupdate** (the default value) communicates directly with the DNS nameserver.
- **FQDN** requests that the DHCP server set the FQDN in the DNS server as specified by the client.
- **Hostname** requests that the DHCP server set the hostname in the DNS server.

To specify the DDNS method in the BMC Web Console

1. [Log in to the BMC Web console](#).
2. Under **Settings** in the left-hand navigation panel, click **Network Settings**, then click **DNS Configuration** to open the **DNS Configuration** page.
3. Select the desired configuration, or contact your network administrator for the recommended settings.
4. Click **Save**.

Related Topics

- ["Overview of the BMC Web Console" on page 277](#)

Unsupported BMC Web Console Features

Some actions within the BMC Web console are not supported for customer use.



Notice: Performing any function that does not appear in ["Overview of the BMC Web Console" on page 277](#) puts the operation of the ztC Endurance system at risk.

Browser Functions to Avoid

Once you are logged in to the BMC Web console, avoid using the following browser functions:

- The back and forward buttons on the browser
- The refresh button on the browser
- The **F5** key on the keyboard
- The backspace key on the keyboard
- The number pad on the keyboard

Instead of using the preceding browser functions, use the buttons located in the user menu in the top right corner of the BMC Web console.

Avoid Using Caps Lock Key in KVM

The BMC KVM interface does not correctly interpret the **Caps Lock** key. Always use the **Shift** key when typing capital letters.

Do Not Use BMC Web Console to Power Off Running System

Use the ztC Endurance console, **not** the BMC Web console, to power off a running ztC Endurance system.

Using the BMC Web console to power off a system may result in the following undesirable outcomes:

- If a user inadvertently powers off the active compute module, application downtime can occur.
- If a user powers off the standby compute module, the system-management software attempts to power it back on in order to maintain maximum system availability.

Part 3: ztC Endurance Supporting Documents

See the following support documents for release information, and for reference and troubleshooting information.

- ["Release Notes: Automated Uptime Layer with Smart Exchange Release 1.1.0.4 \(VMware\)"](#) on page 285
- ["System Reference Information"](#) on page 293

Related Topics

- ["ztC Endurance Hardware Guide"](#) on page 15
- ["ztC Endurance Software Guide"](#) on page 147

11

Chapter 11: Release Notes: Automated Uptime Layer with Smart Exchange Release 1.1.0.4 (VMware)

These Release Notes (updated 10:45 AM EST on 12/19/2025) are for Automated Uptime Layer with Smart Exchange Release 1.1.0.4. See the following sections:

- ["New Features and Enhancements" on page 285](#)
- ["Bug Fixes " on page 286](#)
- ["Important Considerations" on page 286](#)
- ["Known Issues" on page 287](#)
- ["Accessing Stratus Knowledge Base Articles" on page 291](#)
- ["Getting Help" on page 291](#)

New Features and Enhancements

Support for Upgrading

Automated Uptime Layer with Smart Exchange Release 1.1.0.4 supports upgrading the ztC Endurance system software from Release 1.0.x.x or Release 1.1.x.x to Release 1.1.0.4.

To upgrade, follow the instructions in ["Upgrading the System Software" on page 191](#).

If you need to perform a full system software installation of Release 1.1.0.4 on a factory-fresh ztC Endurance system, you may do so as described in ["System Software Installation and Upgrade \(VMware\)" on page 149](#).

Stratus Technologies is now part of Penguin Solutions

Stratus Technologies is now part of Penguin Solutions. To learn more about Penguin Solutions, visit <https://www.penguinsolutions.com>.

Supported Systems

Automated Uptime Layer with Smart Exchange Release 1.1.0.4 runs on the following ztC Endurance systems:

- ztC Endurance 3100 and 3110
- ztC Endurance 5100 and 5110
- ztC Endurance 7100 and 7110
- ztC Endurance 9110

Bug Fixes

BeyondTrust® Backward-Compatibility Support

Due to backward-compatibility issues with recent updates to the BeyondTrust Remote Support Configuration API, attempts to install BeyondTrust updates, or to enable Remote Access on the ztC Endurance standby compute module, could fail in previous ztC Endurance system releases.

ztC Endurance Release 1.1.0.4 (VMWare) addresses the BeyondTrust backward-compatibility issues to support successful BeyondTrust installation and Remote Access enablement.

Important Considerations

Do Not Update the Ubuntu System Software

Do not enable Ubuntu unattended upgrades or update the Ubuntu system software of the Management VM or Standby OS from any source other than Stratus unless instructed to do so. To prevent incompatibilities and ensure the proper fault-tolerant operation of your system, use only the release and software packages that are installed with the Automated Uptime Layer with Smart Exchange software. All supported Ubuntu package updates will be bundled in future releases.

Important Information about VMware License Activation

Broadcom® has changed VMware licensing terms. If you need to activate a Stratus-supplied VMware perpetual license, read the information provided at the following website:

<https://www.stratus.com/go/vmware-activation/>.

Do Not Change BIOS Settings

Do not change any BIOS settings from their default settings without first being told to do so by Penguin Solutions Customer Service.

Known Issues

Do Not Use BIOS to Disable Wake On LAN

Setting Wake On LAN to Disabled in the BIOS does not disable this functionality. Instead, use the VMware settings documented in https://docs.vmware.com/en/VMware-vSphere/7.0/com.vmware.vsphere.vm_admin.doc/GUID-879FA851-2B24-49E6-B58F-F25D0E923D17.html to disable Wake On LAN.

Long Network Delays with PCIe Adapter During I/O Faults

If you add a PCIe adapter to an IP Hash vSwitch with the physical ports configured in a static port group, it could result in long network delays when an I/O module is being brought up.

Manual Reboot of Standby Compute Module on Which `install.sh` Is Running Required to Register Hostname with DNS Server

If you are configuring a system for DHCP and want the hostname to be registered with the DNS server, perform **one** of the following procedures to register it with DNS.

- Manually reboot the standby compute module on which `install.sh` (or `net_config.sh`) is run.
- Run the command `sudo netplan apply`.

Smart Exchange May Cause USB Driver to Issue Spurious Warnings in `vmkernel.log` File

The VMware USB driver may incorrectly view a Smart Exchange operation as an error due to the hardware temporarily "disappearing" and then "reappearing." In this case, the driver may send multiple warnings to the `vmkernel.log` file, similar to the following warnings. You can safely ignore these warnings.

```
2023-02-02T15:26:02.581Z Wa(180) vmkwarning: cpu63:2098291)WARNING: vmkusb:
Retry 1 time(s) for command = 15 (0x0000000000000000,
0x00000000, 0x01013c00)
2023-02-02T15:26:02Z In(182) vmkernel: : Failure^[[0m
```

Remove Existing ASINConnect Data When Installing Replacement Compute Module

If you install a replacement compute module, contact Penguin Solutions Customer Service for instructions on removing existing ASINConnect configuration data before you install ASINConnect on the replacement compute module.

Run `bmc_config` or `net_config` Script Again If Network Reconfiguration Fails

If network reconfiguration fails, run the `bmc_config` script or `net_config` script again.

Install ASNConnect After You Replace a Compute Module

If you replace a compute module, you must contact your authorized Penguin Solutions service representative (see ["Getting Help" on page 299](#)) so they can remove the ASNConnect software associated with the old compute module. After that, you can install ASNConnect on the new compute module as described in ["Enabling ASNConnect" on page 215](#).

System Reports a PSU Error When Power State Changes From No Power to Powered On

When a ztC Endurance system goes from a state of no power to power, the ztC Endurance console may report that one or both PSUs have failed. Some examples of when this situation can occur are during the initial power-on, or if you remove both power cords from the system, reconnect them, and boot the system. As long as both PSU LEDs are solid green, there is no imminent danger, and you can address the issue at a convenient time. However, if the PSU LEDs are solid amber or blinking amber, there may be a legitimate problem with the PSUs that requires prompt attention.

If you encounter this issue:

- If you can physically access the ztC Endurance system:
 - a. Check the PSU LED status. Both PSU LEDs should be solid green, indicating that the PSUs are okay. See [Figure 4-3](#) and [Table 4-4](#).
 - b. Remove the power cord from the PSU that the ztC Endurance console reported as failed. See [Figure 5-19](#).
 - c. Wait for the LED on the affected PSU to completely turn off. See [Figure 4-3](#).
 - d. Reconnect the power cord. See [Connecting the System to Electrical Power](#).
- If the system is remote and you cannot physically access it, contact Penguin Solutions Customer Service for assistance.

IPv6 Must Be Enabled in BMC Web Console

ztC Endurance systems are shipped with the **Enable IPv6** setting selected in the BMC Web console. The ztC Endurance system does not work if you disable this setting.

The **Enable IPv6** setting is located in **Settings>Network Settings>Network IP Settings**. When you select this setting, the **Enable IPv6 DHCP** setting appears; select this setting as well. For more information about the BMC Web console, see ["Overview of the BMC Web Console" on page 277](#).

X710 Adapter Link Still Active After Bringing Down Adapter

If you run the following command for either the Intel X710 PCIe adapter or the Intel X710 embedded adapter, the link should be brought down:

```
esxcli network nic down -n vmnicWW
```

However, although the `esxcfg-nics -l` command reports that the links are down, the link LEDs for the adapter and the switch to which it is attached remain illuminated, indicating that the link is still active. This may result in issues with static-link aggregation configurations, where the switch still sees the link as active even though the adapter has been disabled in the ESXi host.

Reconfiguring System from Static IPv6 Addresses to Dynamic IPv4 Addresses

If your ztC Endurance system has been configured with static IPv6 addresses and you are reconfiguring the system to use dynamic (DHCP) IPv4 addresses, perform the following procedure before running `net_config.sh`:

1. Log in to one of the BMC Web consoles.
2. Select **Settings**, then select **Network Settings**, and then select **Network IP Settings**.
3. On the **Network IP Settings** page:
 - a. Select the **Enable IPv6 DHCP** check box.
 - b. Enter **0** in the **IPv6 Address** field.
 - c. Click **Save** and exit the BMC Web console.

Repeat this procedure on the other BMC Web console.

Spurious PSU Fan Alert After PSU Powers Up

After you remove power from a PSU and then reapply power (either by removing and reinserting a PSU or by unplugging a power cord from the wall and plugging it back in), you may receive an alert that is similar to the following:

```
inventory power supply unit A: sensor Fan_PSUA (7200.000000 RPM) below  
lower critical threshold
```

This spurious alert clears itself within 15 seconds. You then receive an alert that is similar to the following:

```
inventory power supply unit A: sensor Fan_PSUA (RPM 31950.000000) no  
longer below lower critical threshold
```

You can safely ignore these alerts.

Delete Upgrade Files If Management VM Lacks Disk Space

After you upgrade to a newer ztC Endurance release, the files used by the upgrade may cause the management VM to lack disk space. To free up space for the management VM:

1. Select and delete the upgrade kit from the ztC Endurance console as described in "[Upgrade Kits Page](#)" on page 275.
2. Delete the files and folders located in `/opt/stratus/upgrade_kits` as shown in the following example:

```
$ sudo ls /opt/stratus/mgmt/upgrade_kits
temp_kitDir_1204548283  ztcEndurance_upgrade_1.1.0.0-556  ztcEndurance_
upgrade_1.1.0.0-556.kit
$
$ sudo bash -c "rm -r /opt/stratus/mgmt/upgrade_kits/*"
$ sudo ls /opt/stratus/mgmt/upgrade_kits
$
```

Resolve Active Alerts Before Upgrading System Software

If you attempt to upgrade the system software and the ztC Endurance system has active alerts of any kind, including informational alerts, the upgrade fails with the following message:

```
Upgrade cannot proceed until all active alerts have been resolved.
```

After you resolve all active alerts, you can proceed with the upgrade.

Enter Only One DNS Server During Installation

If you try to enter more than one name server for the Standby OS, ESXi host, or Management VM in the installation configuration file (`zen_config.yaml`) or when prompted in the installation script, the script will not proceed until you enter only one name server. If needed, you can add a second name server after installation by using standard Ubuntu or VMware ESXi management utilities.

For the Standby OS specifically, if you earlier added one or more additional name servers and then you replace a compute module or upgrade the system software, you must manually add the additional name server(s) back to the Standby OS. You must do this because those operations reinstall the Standby OS, and any configuration operations outside those specified by the ztC Endurance installation are lost during the reinstallation.

Do Not Use Certain Special Characters in BMC Password

Do not use the special characters `#`, `!`, or `$` in the BMC Web console admin password. If you enter a BMC password that contains these special characters during the installation process, the installation

fails with an Invalid placeholder in string error message.

Reporting Error in zen_verify.sh Script

After a ztC Endurance system is installed, you verify the system's installation by running the zen_verify.sh script from a standby compute module. Currently, if the compute module's SCSI Enclosure Services (SES) version is 3.1.0.24, zen_verify.sh reports a failure of the SES firmware version. This is a reporting error, not an actual failure; Automated Uptime Layer with Smart Exchange Release 1.1.0.4 supports both the 4.0.0.24 and 3.1.0.24 versions of the compute module's SES firmware. You can safely ignore this error.

Management VM Must Be Located on Local Boot Disk

The management VM must be located on the local boot disk (that is, the system that it manages) to prevent it from being migrated to a different system.

strmgmtuser User Appearing in Log Files

If you notice that an error log refers to the strmgmtuser user (for example, The power off at Sun, 19 Jan 08:06:25 +0000 was requested by user/entity strmgmtuser...), be aware that this is the user account that the management server uses to communicate with the ESX host. This is a required user account, and you do not need to take any action.

Accessing Stratus Knowledge Base Articles

For information about accessing Stratus Knowledge Base articles, see ["Getting Help" on page 299](#).

Getting Help

If you have a technical question about ztC Endurance systems, see ["Getting Help" on page 299](#).

12

Chapter 12: System Reference Information

See the following support documents for reference and troubleshooting information.

- ["System Specifications" on page 293](#)
- ["Getting Help" on page 299](#)
- ["Using the BIOS Setup Utility" on page 301](#)
- ["REST API" on page 302](#)

System Specifications

Compute Module (Quantities listed are for each compute module)	
Physical dimensions	Maximum weight: <ul style="list-style-type: none">• 31x0: 10 lb (4.5 kg)• 51x0: 12 lb (5.4 kg)• 71x0: 12 lb (5.4 kg)• 9110: 12 lb (5.4 kg) Length: 22.25 in. (565.2 mm) Width: 8.625 in. (219 mm) Height: 1.625 in. (41.2 mm)
Processors	3100: One Intel® Sapphire Rapids 2.0 GHz 12-core processor

	<p>3110: One Intel Emerald Rapids 2.4 GHz 12-core processor</p> <p>5100: Two Intel Sapphire Rapids 2.0 GHz 12-core processors</p> <p>5110: Two Intel Emerald Rapids 2.4 GHz 12-core processors</p> <p>7100: Two Intel Sapphire Rapids 2.0 GHz 24-core processors</p> <p>7110: Two Intel Emerald Rapids 2.2 GHz 28-core processors</p> <p>9110: Two Intel Emerald Rapids 2.8 GHz 32-core processors</p>
System memory	<p>DIMM capacity: 64 GB</p> <p>31x0: 8 physical, DDR5 DIMM slots. Available DIMM configurations are 64 GB, 128 GB, or 256 GB.</p> <p>51x0: 16 physical, DDR5 DIMM slots. Available DIMM configurations are 128 GB, 256 GB, or 512 GB.</p> <p>71x0: 16 physical, DDR5 DIMM slots. Available DIMM configurations are 256 GB, 512 GB, or 1024 GB.</p> <p>9110: 16 physical, DDR5 DIMM slots. Available DIMM configuration is 1024 GB.</p>
Ports	<p>One UART (USB-C) debug port. For use by Penguin Solutions Customer Service.</p> <p>One VGA port</p> <p>Two USB 3.0 ports</p>
Storage Module	
Physical dimensions	<p>Maximum weight: 10 lb (4.5 kg)</p> <p>Length: 22.25 in. (565.2 mm)</p> <p>Width: 8.625 in. (219 mm)</p> <p>Height: 1.625 in. (41.2 mm)</p>
Disk drives	<p>Up to six U.3 Non-Volatile Memory Express (NVMe) solid-state disk (SSD) drives per storage module. Available as 1.6 TB, 3.2 TB, and 6.4 TB drives.</p>
I/O Module	
Physical dimensions	<p>Maximum weight: 5 lb (2.3 kg)</p> <p>Length: 11.25 in. (285.8 mm)</p>

	<p>Width: 7.125 in. (181 mm)</p> <p>Height: 3.25 in. (82.6 mm)</p>
Ports	<p>Per I/O module:</p> <ul style="list-style-type: none"> • Two 10 GbE ports • One 1 GbE (Management) port
PCIe adapters	<p>See https://www.intel.com/ for detailed information about these PCIe adapters:</p> <ul style="list-style-type: none"> • Intel X550-T2 (10GbE, 2P, Copper) • Intel X710-DA2 (10GbE, 2P, Fibre) • Intel XXV710-DA2 (25 GbE, 2P, Fibre) <p>See https://www.marvell.com/ for detailed information about this Fibre-Channel PCIe adapter:</p> <ul style="list-style-type: none"> • Marvell® Qlogic® QLE2770-SR-SP
Control-Panel (Right) Ear	
Port	One USB 2.0 port per system
PSU	
Physical dimensions	<p>Weight: 3 lb (1.4 kg)</p> <p>Length: 12.25 in. (311.2 mm)</p> <p>Width: 1.5 in. (38.1 mm)</p> <p>Height: 2.875 in. (73 mm)</p>
Rail Kit	
Weight, in box	9 lb (4 kg)
USB Keyboard and USB Mouse	
Physical dimensions	<p>Weight, in box: 2 lb (.9 kg)</p> <p>Depth: 8 in. (20.3 cm)</p> <p>Width: 19 in. (48.3 cm)</p>

	Height: 2.5 in. (6.4 cm; 2U)
U.S. Power Cords (see "Power Cords" on page 43 for detailed power-cord information)	
Weight, in box	2.6 lb (1.2 kg)
AC Power	
Input power (watts)	<p>31x0: 1247.4W at 100V or 1425W at 200V</p> <p>51x0: 1247.4W at 100V or 2970W at 200V</p> <p>71x0: 2970W at 200V</p> <p>9110: 2970W at 200V</p> <div style="border: 1px solid #8B4513; padding: 10px; margin-top: 10px;"> <p>Notice: These input power ratings are established by National Recognized Testing Laboratories (NRTL) to ensure that the product design and branch circuit supplying power can safely support operation of the product. These tests include ranges of stressful environmental operation parameters, application loading, and optional product configurations. These ratings may not reflect your specific product configuration and operational situation (that is, your system's input power may be less than these ratings), but following these ratings provides a safe installation as tested by the NRTL.</p> </div>
Nominal input voltage	<p>31x0: 100-127V or 200-240V, 50/60 Hz</p> <p>51x0: 100-127V or 200-240V, 50/60 Hz</p> <p>71x0: 200-240V, 50/60 Hz</p> <p>9110: 200-240V, 50/60 Hz</p>
Power factor	0.99
Apparent Power (VA)	<p>31x0: 1260 VA 100V (12.6A x 2) or 1440 VA 200V (7.2A x 2)</p> <p>51x0: 1260VA 100V (12.6A x 2) or 3000 VA 200V (15A x 2)</p> <p>71x0: 3000 VA 200V (15A x 2)</p> <p>9110: 3000 VA 200V (15A x 2)</p>
Protective	0.8 mA maximum for each AC power cord

earth/ground current	
Thermal load	31x0: 4097 BTUs/hr 51x0: 5868 BTUs/hr 71x0: 6015 BTUs/hr 9110: 6015 BTUs/hr
Environmental	
Operating temperature	41° F to 95° F (5° C to 35° C) For every 800 ft (243.8 m) above 2000 ft (609.6 m), lower the maximum operating temperature by 0.56° F (1° C).
Storage temperature	-38° F to 140° F (-39° C to 60° C), vented
Operating altitude	0 ft to 10,000 ft (0m to 3,048m). In China markets, regulations may limit installations to a maximum altitude of 6562 ft (2000m).
Maximum rate of temperature change during operation	54° F (12° C) per hour
Relative humidity during operation	10% to 80% (noncondensing)
Relative humidity during storage	5% to 95% (noncondensing)
Maximum rate of change of temperature during storage	68°F (20°C) per hour
Shock	Operating: Minimum - Fixed setting, Half-Sine wave, 2G, 10ms, 10times

	Non-operating: Minimum - Fixed in a rack hitting and dropping at a 15mm edge at 300mm/s x3
Vibration	<p>Operating: Minimum - Fixed setting, log sweep, 5 - 30Hz sine wave, 0.25G, 1.5min x2 (3min) all three axes</p> <p>Non-operating: Minimum - Fixed setting, 3 - 200Hz random wave, 0.59G, 30min, Z-Axis</p>
Physical Dimensions	
Weight	<p>31x0:</p> <ul style="list-style-type: none"> • 67 lb (30.4 kg) to 75 lb (34 kg), without packaging or pallet • 101 lb (45.8 kg), maximum weight with packaging but without pallet <p>51x0 and 71x0:</p> <ul style="list-style-type: none"> • 71 lb (32.2 kg) to 78 lb (35.3 kg), without packaging or pallet • 104 lb (47.1 kg), maximum weight with packaging but without pallet <p>9110:</p> <ul style="list-style-type: none"> • 71 lb (32.2 kg) to 78 lb (35.3 kg), without packaging or pallet • 104 lb (47.1 kg), maximum weight with packaging but without pallet
Height	3.429 in. (87.10 mm)
Width	17.559 in. (446 mm)
Depth	35.826 in. (910 mm)
Acoustics (22C Room Temperature)	
Decibels	<p>31x0:</p> <ul style="list-style-type: none"> • During pre-boot (first 20 seconds after system is powered on): <=77 dBa (PSU fans run at full speed) • During boot: <= 68.5 dBa • During operation: <= 56.1 dBa <p>51x0 and 71x0:</p>

	<ul style="list-style-type: none"> • During pre-boot (first 20 seconds after system is powered on): <=77 dBa (PSU fans run at full speed) • During boot: <= 68.8 dBa • During operation: <= 59.4 dBa <p>9110:</p> <ul style="list-style-type: none"> • During pre-boot (first 20 seconds after system is powered on): <=77 dBa (PSU fans run at full speed) • During boot: <= 68.8 dBa • During operation: <= 59.4 dBa
Internal Battery	
Lithium battery	CR2032

Related Topics

- ["Safety Precautions" on page 51](#)
- ["Memory in ztC Endurance Systems" on page 22](#)
- ["Overview of Stratus ztC Endurance Systems" on page 17](#)

Getting Help

The following resources provide help related to your ztC Endurance system:

- View online documentation at the StrataDOC (ztC Endurance Version) page:
 - <https://ztcendurancedoc.stratus.com>
- After you [log in](#) to the **Penguin Solutions Customer Service Portal** at <https://support.penguinsolutions.com/csm>, you can:
 - [Download software](#).
 - [Search the Knowledge Base](#). The **Knowledge Base** contains technical articles about all Stratus products, including ztC Endurance. In some cases, the online Help directly references these Knowledge Base articles (for example, KBnnnnnnn).



Notice: Access to the **Penguin Solutions Customer Service Portal** requires one or more Stratus products to be covered by an active service agreement. If you have questions about your service agreement, contact your authorized Penguin Solutions service representative.

To log in to the Penguin Solutions Customer Service Portal

1. Log in to the **Penguin Solutions Customer Service Portal** at <https://support.penguinsolutions.com/csm>.

If needed, create a new account as follows:

- a. Click **Register**.
- b. Enter your contact information, including your company email address and registration code, and click **Submit**.

Your company email address must include a domain name (for example, stratus.com) for a company that is a registered customer of Penguin Solutions. The portal sends an email to administrators of the company's account to approve the request.

- c. Upon approval, click the link in the email that you receive from Penguin Solutions.
- d. Enter a new password and finish configuring your account.

If you need assistance creating an account, contact your authorized Penguin Solutions service representative.

To download software from the Penguin Solutions Customer Service Portal

1. Log in to the **Penguin Solutions Customer Service Portal** at <https://support.penguinsolutions.com/csm>.
2. On the **Welcome to Customer Service** page, click **Software Downloads**.
3. On the **Software Downloads** page, select your product, operating system, and model, and then follow the prompts to download the desired software.

To access the Knowledge Base from the Penguin Solutions Customer Service Portal

1. Log in to the **Penguin Solutions Customer Service Portal** at <https://support.penguinsolutions.com/csm>.
2. On the **Welcome to Customer Service** page, do one of the following:
 - In the **Search** box, enter keywords or the KB article number (KBnnnnnnn) associated with the information you need, and then click the search button.
 - Click **Knowledge**, click the name of a product, and then browse available articles.

If you cannot resolve your questions with these online resources, and the system is covered by a service agreement, contact your authorized Penguin Solutions service representative. For information, see the ztC Endurance Support page at:

<https://www.penguinsolutions.com/en-us/support>

Related Topics

- "ztC Endurance Supporting Documents" on page 283

Using the BIOS Setup Utility

You use the BIOS setup utility to modify BIOS settings and control system hardware.

To start the utility, as the system starts to boot and the Stratus ztC Endurance screen appears, press either the **Delete** key or the **Esc** key until the BIOS setup utility appears.



Notice: Do not change any BIOS settings from their default settings without first being asked to do so by Penguin Solutions Customer Service.

Important Considerations When Using the BIOS Setup Utility

Consider the following important issues when you use the BIOS setup utility:

- While you are making changes to the BIOS, make sure that only one compute module is running; the other compute module must be powered down. The safest way to do this is to power on one compute module at a time. See "[Shutting Down and Restarting a Compute Module](#)" on page 241.
- Stratus software does change some BIOS settings from their default values, but only at specific times. For example, Stratus software enables the OS Watchdog Timer after the software installation is complete.

Related Topics

- ["Upgrading the System Software" on page 191](#)

REST API

ztC Endurance systems support the Representational State Transfer (REST) application programming interface (API). With access to the REST API operations, you can collect system information and execute some administrative tasks. You can use the REST API to monitor and manage the ztC Endurance system from any location that can access the system over the network.

The system provides the REST API and interactive REST API documentation through the OpenAPI (also known as Swagger™) Specification. You can access the documentation directly on the ztC Endurance system.

To begin exploring the REST API on ztC Endurance systems, see the following sections:

- ["Accessing the REST API Documentation" on page 302](#)
- ["Logging In for REST API Testing" on page 302](#)

Accessing the REST API Documentation

In a Web browser, open the following URL, which includes the hostname or IP address of your ztC Endurance console:

```
https://console_hostname_or_IP_address/apidoc
```

For example, if the hostname of your ztC Endurance console is `https://sys22-ztcmgmt.ops.yourcompany.com`, the URL for the REST API documentation is `https://sys22-ztcmgmt.ops.yourcompany.com/apidoc`.

The URL takes you to the REST API documentation page. This page describes the API operations and syntax, and provides a helpful interface you can use to try the operations on your own system.

Logging In for REST API Testing

Notes:



1. The system has a limit of 9 login sessions.
2. Most operations on the REST API documentation page do not require you to perform the following procedure and instead simply require you to enter a username and password after you click **Execute**. However, if you want to use all operations listed on the REST API documentation page, you must perform the following procedure.

1. Open the REST API documentation page.
2. Click **session_api** to expand it. The system displays the syntax for the **session_api** operation.
3. Click **POST /sessions** to expand it, and then click **Try it out**.
4. Under **LoginRequest**, replace `string` next to `username` and `password` with the username and password for a user account with the appropriate level of privileges for the REST API operations that you want to perform. The new username and password appear in bold in the following example.

```
{
  "username": "admin",
  "password": "admin"
}
```

5. Click **Execute**.
6. Scroll down to **Server response** and view **Response body**. If the operation is successful, the response contains a REST API session authentication token (`authToken`). The authentication token appears in bold in the following example. If the operation is unsuccessful, the response might contain a message similar to **Unauthorized**.

```
{
  "authToken": "a8ab7d17f4f3721494eb646ce81dfc24",
  "email": "jbrown@abccompany.com",
  "maxAge": 600000,
  "role": "admin",
  "status": "success"
}
```

7. Upon a successful login, copy the authorization token text located between the quotation marks for use in a subsequent step.
8. At the top of the REST API documentation page, on the right side, click **Authorize**.
9. Under **key (apiKey)**, in the **Value** field, paste the authorization token text, and then click **Authorize**. This saves your authentication token in the request header for any operations that you “execute” from the REST API documentation page.



Note: The token expires after 10 minutes, and you need to repeat this step to create a new token.

To clear the token, use the **Logout** button next to it on the **Authorize** dialog box.

10. Click **Close** or **X** to close the dialog box and return to the REST API documentation page.
11. Proceed with your REST API testing.

End-User License Agreements and Warranty

When you install a ztC Endurance system running Automated Uptime Layer with Smart Exchange, you must read and accept end-user license agreements (EULAs) associated with the system and software. You can read the following EULAs, which are required for Automated Uptime Layer with Smart Exchange, on the Stratus web site:

Stratus Technologies ztC Endurance Series Software End User License Agreement ztC Endurance Service Terms

Stratus Technologies ztC Endurance Products Limited Return-to-Factory Hardware Warranty

<https://www.stratus.com/services-support/customer-support/platform-support/warranty-info/>

Additional EULAs cover third-party software components that are also included with the ztC Endurance system. By accepting the Stratus Technologies ztC Endurance Software EULA and using the ztC Endurance system, you also agree to the terms of the following EULAs:

GNU General Public License (GPL)

<https://www.gnu.org/licenses/gpl-3.0.en.html>

GNU Lesser General Public License

<https://www.gnu.org/licenses/lgpl-3.0.en.html>

Related Topics

- "Installing VMware ESXi and Deploying the Management VM" on page 165

Glossary

A

ActiveService Network (ASN)

The infrastructure that enables communication between a server and Penguin Solutions Customer Service or your authorized service representative. Customers can connect to ASN through a modem or over the Internet. Through ASN, alerts can be sent to customer service or your authorized service representative when an unusual event occurs on the system. ASN also enables customer service or your authorized service representative to access the server.

B

Baseboard Management Controller (BMC)

Controller used for out-of-band monitoring and management of the ztC Endurance system. Each ztC Endurance system includes two BMCs; the primary BMC monitors the status of system components, even when system power is off. BMCs are equipped with an Ethernet port that can be connected to the Stratus ActiveService Network (ASN). BMCs can communicate with the ASN even when the host operating system is unavailable. This allows remote management, and, if necessary, troubleshooting by Penguin Solutions Customer Service or your authorized service representative over the internet.

BIOS (basic input/output system)

The program a computer's microprocessor uses to start the computer system after it is powered on. It also manages data flow between the computer's operating system (OS) and attached devices, such as the hard disk, video adapter, keyboard, mouse, and printer.

C

compute module

A customer-replaceable unit (CRU) located at the front of the ztC Endurance system. It is equipped with processors, DIMMs, BIOS, BMC, fans, and other technology to boot and run the ztC Endurance system. Each system contains two compute modules.

control-panel ear

A module located at the front right of the ztC Endurance system. It houses a USB 2.0 port, power button for the ztC Endurance system, and LEDs that indicate system power status (PWR), fault conditions (ATTN), and module identification status (UID).

customer-replaceable unit (CRU)

Modules that allow on-site personnel to easily remove and replace faulty components with minimal training or tools. ztC Endurance CRU modules are compute modules and their DIMMs, storage modules and their disk drives, I/O modules and their PCIe adapters, and PSUs.

D

DIMM

Dual In-line Memory Module. A type of computer memory module that contains random-access memory (RAM)

E

e-Alert

Email alert that the ztC Endurance system sends to system administrators whenever the system detects an event requiring administrator attention.

F

fully qualified domain name

The complete domain name of a specific computer, or host, online. A fully qualified domain name (FQDN) is composed of a hostname and a domain name, separated by a period. An FQDN designates the specific location of an object within the Domain Name System (DNS) hierarchy and allows each entity connected to the Internet to be uniquely identified and located within the Internet framework.

I

I/O module

CRU modules located at the rear of the ztC Endurance system. Each I/O module houses one 1G Ethernet port for connection to a management LAN, two 10G ports for connection to business networks, status LEDs, and five PCIe 4.0 slots for half-height PCIe adapters. The ztC Endurance system contains two I/O modules.

Identify button

Button that illuminates the ID LED on a specific system or component for 30 seconds, so that you can locate it. Identify buttons are found on the front of compute modules, and on the Hardware page of the ztC Endurance console.

IPMI

Intelligent Platform Management Interface. A set of standardized specifications for hardware-level management of computer servers

L

LUN

A Stratus software-implemented disk device. LUNs are typically duplex, meaning a mirrored set of two raw disks. If a raw disk is missing or not yet configured, the LUN is a single, raw, simplex disk.

M

maintenance mode

A ztC Endurance state that takes a module offline so that it can be serviced.

management LAN

The Local Area Network (LAN) used for management of the ztC Endurance system. The I/O modules house a 1G MGMT port for connection to an out-of-band management LAN.

MTBF

The MTBF, or mean time between failure, is the average time that a device works without an error. Regarding the MTBF: 1) Fault and event times are recorded for compute, I/O, and storage modules, as well as PSUs and disks. 2) Events are not faults, but sufficient numbers of certain events, with average in-service time between them falling below a particular threshold, will be counted as a fault. 3) Sufficient numbers of faults, with average in-service time between them falling below a particular threshold, will cause a device to be removed from service or flagged for replacement.

N

Non-maskable interrupt (NMI)

A process, initiated when the system is not responding, where the system controller tries to restart the system by saving the contents of memory to a dump file, and then restarting the operating system. The interrupts are intended to keep all CPUs synchronized while the system controller attempts to resolve the problem.

NVMe (Non-Volatile Memory Express) drive

A protocol designed to use the PCI Express (PCIe) bus to connect SSD (solid-state drive) storage to servers or CPUs. NVMe was created by a consortium of large IT providers in 2008 to provide improved speed and performance.

P

PCIe slot/PCIe adapter

Peripheral Component Interconnect Express (PCIe or PCI-E) is a serial expansion bus standard for connecting a computer to one or more peripheral devices. PCIe provides lower latency and higher data transfer rates than parallel busses such as PCI and PCI-X.

Penguin Solutions Customer Service Portal

Location for downloading ztC Endurance system software, reading knowledge base articles, and getting support. Access to the Penguin Solutions Customer Service Portal requires one or more Stratus products to be covered by an active service agreement, and the creation of an account. The Penguin Solutions Customer Service Portal is located at <https://support.penguinsolutions.com/csm>.

power supply unit (PSU)

Unit that connects the ztC Endurance system to electrical power. Each system includes two PSUs, located at the rear.

R

reboot exchange

A process for switching from the active compute module to the standby compute module when a Smart Exchange is not possible due to firmware mismatches between the two modules. During a reboot exchange, the system: 1) Instructs the standby compute module to become active. 2) Shuts down the original active compute module. 3) Reboots the new active compute module, which automatically takes ownership of all I/O and storage connected to the original active compute module. 4) Starts the system software on the new active compute module. A

reboot exchange is typically initiated during software upgrades, firmware updates, and troubleshooting procedures.

S

secure erase

A process that permanently removes all data from a disk or solid state drive (SSD). After a device has been securely erased, you can safely use it for other purposes, such as backup images.

Simple Network Management Protocol (SNMP)

Network protocol used to monitor the status of network-connected devices. Configuring SNMP settings on ztC Endurance allows remote monitoring of the system by management applications, and allows the system to send messages to designated recipients if alert conditions occur.

Smart Exchange

A proprietary process that maintains system availability and protects against data loss. If the ztC Endurance system detects a degradation or failure within the active compute module, Smart Exchange: 1) Automatically activates the standby compute module and copies over in-process data. 2) Reroutes all I/O and storage connected to the original active compute module to the newly activated compute module. Smart Exchange occurs while the system is running and, except for a very brief pause (usually less than one second), is undetectable to the operating system and customer applications.

standby power

Low-level power that remains present even after the ztC Endurance system has been powered down. Standby power enables the primary Baseboard Management Controller (BMC) to monitor the status of system components, even when system power is off. Using standby power, administrators or ztC Endurance Customer Service (if authorized) can connect to the system through the 1G management port to diagnose problems, or to turn system power on and off from a remote location. To completely shut off power, the power cords must be unplugged.

storage module

CRU modules located at the front of the ztC Endurance system. Storage modules are equipped with status LEDs and include six slots for data disk drives. Each ztC Endurance system contains two storage modules.

Z

ztC Endurance console

A browser-based interface that provides management and monitoring of a ztC Endurance system from a remote management computer. You can perform many administrative operations from the console because it provides access to the system as a whole, as well as to individual modules, components of modules, and other resources.