

**PENGUIN**<sup>®</sup>  
SOLUTIONS 

**Stratus**  
ztC Endurance<sup>™</sup>

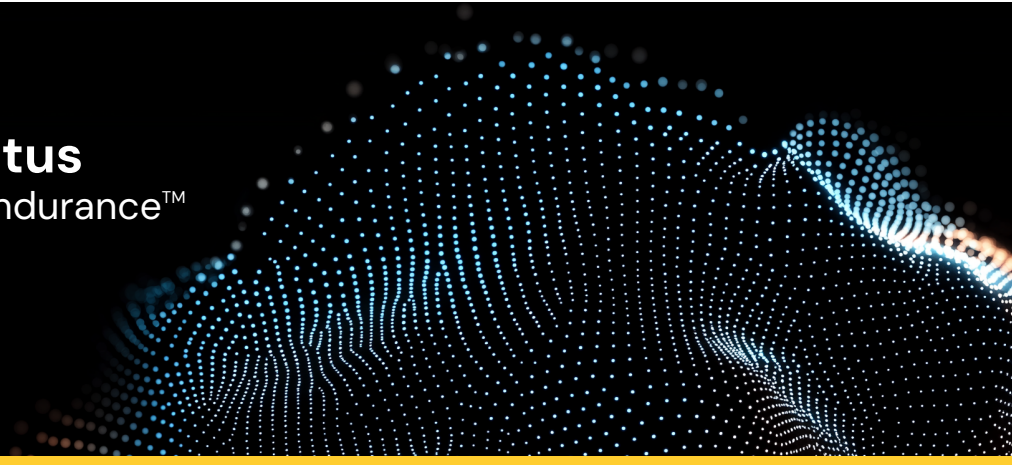

## ztC Endurance 3xx0, 5xx0, and 7xx0 Systems: User's Guide (Windows) (R006C)

## Notice

The information contained in this document is subject to change without notice.

UNLESS EXPRESSLY SET FORTH IN A WRITTEN AGREEMENT SIGNED BY AN AUTHORIZED REPRESENTATIVE OF PENGUIN SOLUTIONS, PENGUIN SOLUTIONS MAKES NO WARRANTY OR REPRESENTATION OF ANY KIND WITH RESPECT TO THE INFORMATION CONTAINED HEREIN, INCLUDING WARRANTY OF MERCHANTABILITY AND FITNESS FOR A PURPOSE.

Penguin Solutions assumes no responsibility or obligation of any kind for any errors contained herein or in connection with the furnishing, performance, or use of this document. Software described in Penguin Solutions' documents (a) is the property of Penguin Solutions (PENG) Ireland Limited or the third party, (b) is furnished only under license, and (c) may be copied or used only as expressly permitted under the terms of the license.

Penguin Solutions' documentation describes all supported features of the user interfaces and the application programming interfaces (API) developed by Penguin Solutions. Any undocumented features of these interfaces are intended solely for use by Penguin Solutions personnel and are subject to change without warning.

This document is protected by copyright. All rights are reserved. Penguin Solutions grants you limited permission to download and print a reasonable number of copies of this document (or any portions thereof), without charge, for your internal use only, provided you retain all copyright notices and other restrictive legends and/or notices appearing in the copied document.

## Copyrights

Stratus, the Stratus logo, Stratus ztC, the Stratus Technologies logo, the Stratus 24x7 logo, Stratus ztC Endurance, Smart Exchange, and Automated Uptime Layer with Smart Exchange are trademarks of Penguin Solutions, Inc. or its affiliates.

Intel and the Intel Inside logo are registered trademarks and Xeon is a trademark of Intel Corporation or its subsidiaries in the United States and/or other countries/regions.

Microsoft, Windows, Windows Server, and Hyper-V are either registered trademarks or trademarks of Microsoft Corporation in the United States and/or other countries/regions.

VMware, vSphere, and ESXi are registered trademarks or trademarks of VMware, Inc. in the United States and/or other jurisdictions.

Linux is a registered trademark of Linus Torvalds in the United States and other countries.

Oracle is a trademark of Oracle International Corporation.

Google and the Google logo are registered trademarks of Google Inc., used with permission. The Chrome browser is a trademarks of Google Inc., used with permission.

Mozilla and Firefox are registered trademarks of the Mozilla Foundation.

Red Hat is a registered trademarks of Red Hat, Inc. in the United States and other countries.

Ubuntu and Canonical are registered trademarks of Canonical Ltd.

All other trademarks and registered trademarks are the property of their respective holders.

Manual Name: ztC Endurance 3xx0, 5xx0, and 7xx0 Systems: User's Guide (Windows)

Part Number: R006C

Revision Number: 00

Product Release Number: Automated Uptime Layer with Smart Exchange Release WIN-2.0.0.0

Publication Date: Tuesday, February 17, 2026

Penguin Solutions

5 Mill and Main Place, Suite 500

Maynard, Massachusetts 01754-2660

© 2026 Penguin Solutions (PENG) Ireland Limited. All rights reserved.

## Table of Contents

---

ztC Endurance 3xx0, 5xx0, and 7xx0 Systems: User's Guide (Windows) .....	14
<b>Part 1: ztC Endurance Hardware Guide .....</b>	<b>15</b>
<b>Chapter 1: Overview of Stratus ztC Endurance Systems .....</b>	<b>17</b>
System Front .....	17
System Rear .....	18
System Ports .....	19
System CRU Modules .....	20
Compute Module .....	21
Memory in ztC Endurance Systems .....	22
Memory Components in Each Compute Module .....	23
Memory in ztC Endurance 31x0 Systems .....	24
Memory in ztC Endurance 51x0 Systems .....	25
Memory in ztC Endurance 71x0 Systems .....	26
Storage Module .....	26
Disk Drives .....	27
Understanding Disk-Drive Numbering .....	28
Installing Additional Disk Drives .....	28
Important Considerations When Installing Disk Drives .....	29
I/O Module .....	29
PCIe Adapters .....	30
Understanding PCIe-Slot Numbering .....	31
Installing Additional PCIe Adapters .....	32
Important Considerations When Installing PCIe Adapters .....	32
Valid PCIe Configurations .....	33
PSUs .....	33
Peripheral Components .....	34

---

<b>Chapter 2: Planning a Site for ztC Endurance Systems</b> .....	<b>35</b>
Site Planning Checklist .....	36
Planning for ActiveService Network Connectivity .....	36
Planning for Network Connectivity .....	37
Planning AC Power .....	37
Planning Space for the System .....	37
Working with Other Groups .....	38
Electrical Power Planning .....	38
Redundant Power Sources .....	38
AC Power and HVAC Service Requirements .....	39
Electrical Power Connections .....	39
Power Cords .....	40
Grounding Requirements .....	43
Space Planning .....	44
Room Requirements .....	44
Planning for Cables .....	45
Cabinet Requirements .....	45
Site Planning for Peripheral Components .....	48
<b>Chapter 3: Installing and Connecting the ztC Endurance System Hardware</b> .....	<b>49</b>
Safety Precautions .....	49
Warnings, Cautions, Notices, and Notes .....	50
Safety Notices .....	50
Environmental Warnings .....	55
Safety Precautions When Setting Up and Shipping Equipment .....	56
Power Cord Warnings and Cautions .....	56
Electrostatic Discharge (ESD) Warnings .....	59
Rack System Installation .....	60

---

---

Installing the System in a Cabinet .....	60
Numbering the Vertical Rails .....	62
Preparing the Support Rails for Installation .....	64
Attaching the Support Rails and Inserting the System .....	67
Completing the Hardware Set-up .....	70
To connect the system to AC power mains .....	73
<b>Chapter 4: Operating the ztC Endurance System Hardware .....</b>	<b>81</b>
Hardware Operation .....	81
Standby Power .....	81
System Power .....	82
Pressing the Power Button .....	82
Starting Up the System .....	82
Shutting Down the System .....	83
Enabling and Disabling Wake on LAN .....	85
Fan Speed .....	85
Troubleshooting the Hardware .....	85
Status LEDs .....	86
Using the ATTN LEDs to Diagnose Faults .....	94
Internal Disk Drive Problems and Solutions .....	95
Using the NMI Button .....	96
<b>Chapter 5: Removing and Replacing System Components .....</b>	<b>97</b>
General Servicing Information .....	97
Unpacking System Components .....	98
Storing System Components .....	99
Repacking System Components .....	99
Replacing System Components .....	100
General Safety Precautions .....	101

---

---

Preparing to Replace System Components .....	101
Using ESD Precautions .....	102
Observing Cautions and Warnings .....	102
Removing and Replacing a Compute Module .....	103
Replacing, Adding, and Upgrading Memory .....	106
Terminology for Memory Procedures .....	106
Important Cautions and Notes .....	107
Replacing DIMMs .....	107
Adding DIMMs .....	109
Removing and Replacing a Storage Module .....	112
Removing and Inserting a Disk Drive .....	114
Removing and Replacing an I/O Module .....	119
Removing and Installing a PCIe Adapter .....	122
Removing and Replacing a PSU and Power Cords .....	127
<b>Chapter 6: Electrical Circuit and Wiring Information .....</b>	<b>133</b>
Fault Protection Requirements .....	133
Grounding Considerations .....	133
Circuit Wiring Diagrams .....	134
Electrical Power Connectors .....	140
<b>Part 2: ztC Endurance Software Guide .....</b>	<b>145</b>
<b>Chapter 7: System Software Installation (Windows) .....</b>	<b>147</b>
Installing the System Software .....	147
Preparing to Install the System Software .....	148
Password and Installation Settings Printable Worksheet .....	161
Starting a Factory-Installed System for the First Time .....	164
Next Steps .....	166
Performing a Full System Software Installation .....	167

---

---

Overview .....	167
Downloading a Windows Server ISO Image .....	168
Configuring the BMC Network Settings. ....	177
Installing Windows and AUL-Smart Exchange .....	179
Post-Installation Tasks .....	184
Verifying the System Software Installation .....	184
Configuring System-Management Options .....	187
Configuring the BMCs for Remote System Management .....	187
Configuring the Windows Host for Remote System Management .....	188
Configuring SSH for Remote System Management .....	188
Configuring Network Interfaces .....	188
Installing and Enabling Language Support .....	190
<b>Chapter 8: System Software Administration (Windows) .....</b>	<b>191</b>
Managing Disks .....	191
Using Storage Spaces on Data Disks .....	191
Disk Requirements for Using Storage Spaces .....	192
Differences When Creating RDM Disks .....	192
Differences When Creating Storage Pool Virtual Disks .....	193
Adding and Mirroring Data Disks .....	193
Mirroring Disks During the Installation .....	193
Mirroring Data Disks Post-Installation .....	194
Configuring and Managing Ethernet PCIe Adapters .....	194
Teaming Utilities .....	195
Using the LBFO Teaming Script to Manage Ethernet Teams .....	196
Using the NIC Teaming Utility to Manage Ethernet Teams .....	200
Types of Fault-Tolerant Teams .....	202
Fault-Tolerant Ethernet Teams and IP Multicasting .....	202

---

---

Virtual LANs .....	203
Configuring Ethernet Teams .....	204
Managing Ethernet Teams .....	212
Setting the Locally Administered Address for a Team or VLAN .....	213
Removing Ethernet PCIe Adapters from a Team .....	215
Physically Replacing Removed Adapters .....	216
Adding Ethernet PCIe Adapters to a Team .....	217
Deleting Ethernet Teams .....	218
Troubleshooting Ethernet Teams and Ethernet PCIe Adapters .....	218
Fixing Duplicate Network Adapter Names .....	219
Avoid Disabling an LBFO Team .....	219
NIC Teaming Utility Fails When an I/O Module Is Offline .....	220
NIC Teaming Utility Fails If the Host Name Changes .....	221
Updating Network IP Configuration Settings .....	222
Configuring Windows Components .....	225
Installing Windows Updates .....	225
Enabling ASNConnect .....	226
Checking Your Connection to ASNConnect .....	226
Installing ASNConnect on the ztC Endurance System .....	227
Installing a Custom Security Certificate .....	227
Changing Passwords on a ztC Endurance System .....	229
<b>Chapter 9: Using the ztC Endurance Console .....</b>	<b>235</b>
ztC Endurance Console .....	235
ztC Endurance Console Requirements .....	236
Compatible Internet Browsers .....	237
Logging In to the ztC Endurance Console for the First Time .....	237
Logging In to the ztC Endurance Console .....	238

---

---

Editing Your User Information .....	240
Dashboard Page .....	241
Understanding the ztC Endurance System Diagram .....	242
Alert Symbols .....	242
Resolving Outstanding Alerts on the Dashboard .....	243
Configuring the Mail Server .....	243
Hardware Page .....	245
Hardware States .....	245
Hardware Activity Types .....	246
Identifying a System or Component .....	250
Using Maintenance Mode .....	250
Shutting Down and Restarting a Compute Module .....	252
Volumes Page .....	253
Specifying Owner Information .....	254
Registering the System .....	254
Configuring Users .....	258
Managing User Accounts .....	259
Alert History Page .....	261
Support Logs Page .....	262
Creating a Diagnostic File .....	262
Deleting a Diagnostic File .....	263
Configuring e-Alerts .....	263
Managing SNMP .....	264
Configuring SNMP Settings .....	265
Managing Firewall Settings .....	265
Configuring Remote Support Settings .....	267
To configure ASN "heartbeat" alarms .....	269

---

---

Configuring Internet Proxy Settings .....	269
<b>Chapter 10: Overview of the BMC Web Console .....</b>	<b>271</b>
Prerequisites for Using the BMC Web Console .....	271
Required Browser Settings .....	272
Additional Requirements .....	272
Connecting to the BMC Web Console .....	272
Logging In to the BMC Web Console .....	273
Accessing Documentation from the BMC Web Console .....	274
Configuring DNS Settings in the BMC Web Console .....	274
To specify the DDNS method in the BMC Web Console .....	275
Unsupported BMC Web Console Features .....	275
Browser Functions to Avoid .....	275
Avoid Using Caps Lock Key in KVM .....	275
Do Not Use BMC Web Console to Power Off Running System .....	275
<b>Part 3: ztC Endurance Supporting Documents .....</b>	<b>277</b>
<b>Chapter 11: Release Notes: Automated Uptime Layer with Smart Exchange Release WIN-2.0.0.0 (Windows) .....</b>	<b>279</b>
New Features and Enhancements .....	279
Important Considerations .....	279
Hyper-V Not Supported in Automated Uptime Layer with Smart Exchange Release WIN-2.0.0.0 .....	279
Do Not Update the Ubuntu System Software .....	280
Do Not Change BIOS Settings .....	280
Known Issues .....	280
Do Not Use BIOS to Disable Wake On LAN .....	280
Long Network Delays with PCIe Adapter During I/O Faults .....	280
System Reports a PSU Error When Power State Changes From No Power to Powered On .....	280

---

---

IPv6 Must Be Enabled in BMC Web Console .....	281
Reconfiguring System from Static IPv6 Addresses to Dynamic IPv4 Addresses .....	281
Enter Only One DNS Server During Installation .....	281
Reporting Error in zen_verify.sh Command .....	282
Do Not Use Certain Special Characters in BMC Password .....	282
Windows Subsystem for Linux Not Supported .....	282
Do Not Install OpenSSH Server Optional Feature .....	282
Installation Fails If System Connected to External Storage .....	282
Disk Manager May Display Incorrect Number of Disks During Installation .....	282
Do Not Install Windows Updates Before You Check with Penguin Solutions Customer Service .....	282
Do Not Modify Time Zone Except for Windows Host .....	283
Recovering Storage Pool After Reinstalling Automated Uptime Layer with Smart Exchange .....	283
Replacement Boot Disks Not Recognized by Windows Software When Moved to Another System .....	283
Recovering Degraded Data Disks After Installation .....	283
Application Popup Event Log Messages Appear After Installing Automated Uptime Layer with Smart Exchange .....	285
Delay in Client/Server-Based Applications During Smart Exchange While Communicating Over IPv4 Addresses .....	285
Do Not Burn Firmware on Active Compute Module During Windows Installation .....	285
Possible Message About PackageManagement During System Software Installation .....	285
Running net_config.sh Requires a Planned Maintenance Period .....	286
Accessing Stratus Knowledge Base Articles .....	286
Getting Help .....	286
<b>Chapter 12: System Reference Information .....</b>	<b>287</b>
System Specifications .....	287
Getting Help .....	293

---

---

Using the BIOS Setup Utility .....	294
Important Considerations When Using the BIOS Setup Utility .....	295
Security .....	295
OpenSSH Settings .....	295
REST API .....	295
Accessing the REST API Documentation .....	296
Logging In for REST API Testing .....	296
End-User License Agreements and Warranty .....	297
Microsoft Windows Software License Terms .....	298
<b>Glossary .....</b>	<b>299</b>

## ztC Endurance 3xx0, 5xx0, and 7xx0 Systems: User's Guide (Windows)

The ztC Endurance 3xx0, 5xx0, and 7xx0 Systems: User's Guide (Windows) (R006C) describes ztC Endurance systems, how to deploy them, and how to use them.

Part 1: [ztC Endurance Hardware Guide](#) describes the ztC Endurance hardware. It includes:

- ["Overview of Stratus ztC Endurance Systems"](#) on page 17
- ["Planning a Site for ztC Endurance Systems"](#) on page 35
- ["Installing and Connecting the ztC Endurance System Hardware"](#) on page 49
- ["Operating the ztC Endurance System Hardware"](#) on page 81
- ["Removing and Replacing System Components"](#) on page 97
- ["Electrical Circuit and Wiring Information"](#) on page 133

Part 2: [ztC Endurance Software Guide](#) describes the ztC Endurance software. It includes:

- ["System Software Installation \(Windows\)"](#) on page 147
- ["System Software Administration \(Windows\)"](#) on page 191
- ["Using the ztC Endurance Console"](#) on page 235
- ["Overview of the BMC Web Console"](#) on page 271

Part 3: [ztC Endurance Supporting Documents](#) describes the ztC Endurance supporting documents. It includes:

- ["Release Notes: Automated Uptime Layer with Smart Exchange Release WIN-2.0.0.0 \(Windows\)"](#) on page 279
- ["System Reference Information"](#) on page 287
- ["System Specifications"](#) on page 287

### Next Steps:

To install the system hardware, see ["Installing and Connecting the ztC Endurance System Hardware"](#) on page 49.

To install the system software, see ["Installing the System Software"](#) on page 147.

## Part 1: ztC Endurance Hardware Guide

The ztC Endurance Hardware Guide discusses the following topics:

- ["Overview of Stratus ztC Endurance Systems" on page 17](#)
- ["Planning a Site for ztC Endurance Systems" on page 35](#)
- ["Installing and Connecting the ztC Endurance System Hardware" on page 49](#)
- ["Operating the ztC Endurance System Hardware" on page 81](#)
- ["Removing and Replacing System Components" on page 97](#)
- ["Electrical Circuit and Wiring Information" on page 133](#)

### Related Topics

- ["ztC Endurance Software Guide" on page 145](#)
- ["ztC Endurance Supporting Documents" on page 277](#)



# 1

## Chapter 1: Overview of Stratus ztC Endurance Systems

A Stratus ztC Endurance system consists of a system chassis that you install on rails in a cabinet. At the front and rear of the system chassis, you view LEDs and access modules for maintenance. Each module is a customer-replaceable unit (CRU) that you can remove and replace.

Read the following topics to familiarize yourself with your ztC Endurance system:

- ["System Front" on page 17](#)
- ["System Rear" on page 18](#)
- ["System CRU Modules" on page 20](#)
- ["Peripheral Components" on page 34](#)
- ["Planning a Site for ztC Endurance Systems" on page 35](#)

### Next Steps

When you are familiar with the system, install the system hardware as described in ["Installing and Connecting the ztC Endurance System Hardware" on page 49](#).



**Note:** As you read through the installation topics, the sections labeled **Next Steps** provide links that help you move to the next logical step in a procedure.

### System Front

The front of the system consists of two [storage modules](#) and two [compute modules](#). Each storage module and each compute module is a [CRU module](#). The system front also includes the control-panel ear on the right and a blank ear on the left. See [Figure 1-1](#).

For more information, see:

- "System CRU Modules" on page 20 for information about the compute module (which contains [DIMMs](#)), and the storage module (which contains [disk drives](#))
- "Status LEDs" on page 86 for information about the LEDs on the control-panel ear, the storage module, and the compute module
- "System Power" on page 82 for information about the power button on the control-panel ear
- "Installing and Connecting the ztC Endurance System Hardware" on page 49 for information about installing and connecting the hardware
- "System Specifications" on page 287 for detailed specifications about the system and its components

Figure 1-1: System Front

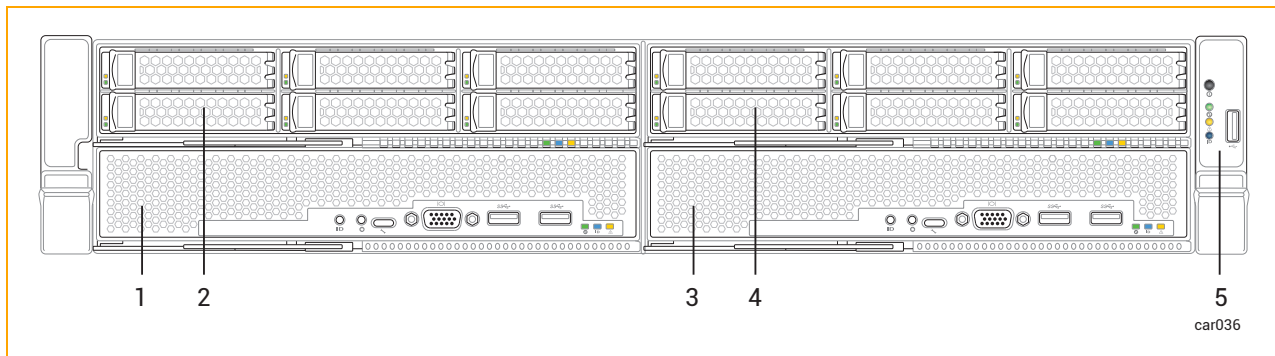

1	Compute module A	4	Storage module B
2	Storage module A	5	Control-panel ear
3	Compute module B		



**Note:** The left ear contains a QR code that links to ztC Endurance Release Notes and documentation at <https://ztcendurancedoc.stratus.com>.

### Related Topics

- "Planning a Site for ztC Endurance Systems" on page 35
- "System Reference Information" on page 287

### System Rear

The rear of the system consists of two power-supply units (PSUs) and two I/O modules. Each PSU and each I/O module is a [CRU module](#). See [Figure 1-2](#).

For more information, see:

- ["System CRU Modules" on page 20](#) for information about the I/O modules and PSUs
- ["Status LEDs" on page 86](#) for information about the LEDs on the I/O module
- ["Installing and Connecting the ztC Endurance System Hardware" on page 49](#) for information about installing and connecting the hardware
- ["System Specifications" on page 287](#) for detailed specifications about the system and its components

**Figure 1-2: System Rear**

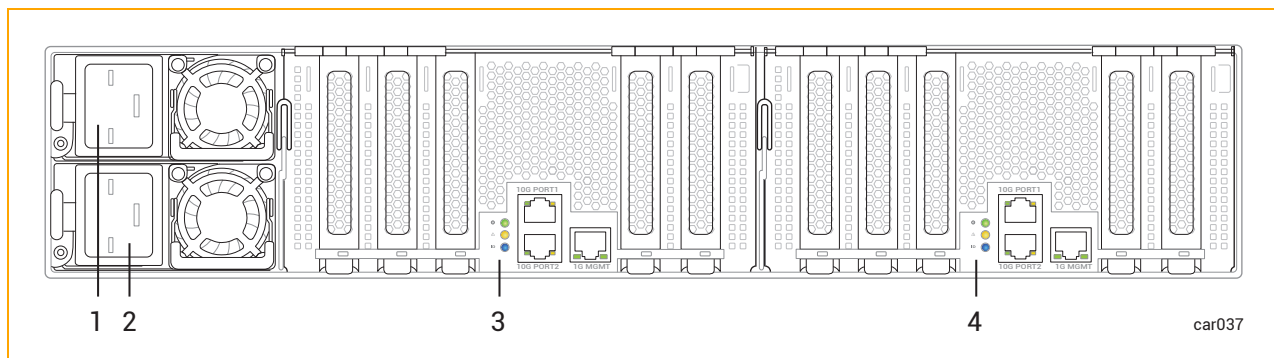

1	Power-supply unit (PSU) A	3	I/O module A
2	Power-supply unit (PSU) B	4	I/O module B

### Related Topics

- ["Planning a Site for ztC Endurance Systems" on page 35](#)
- ["System Reference Information" on page 287](#)

### System Ports

Ports are located at the front ([Figure 1-3](#)) and rear ([Figure 1-4](#)) of the system.



**Note:** The USB 2.0 port on the control-panel ear is the only front port that stays with the active compute module through a Smart Exchange operation. That is, after the active compute module becomes the standby module, the USB 2.0 port automatically connects to the new active compute module.

Figure 1-3: System Ports: Front

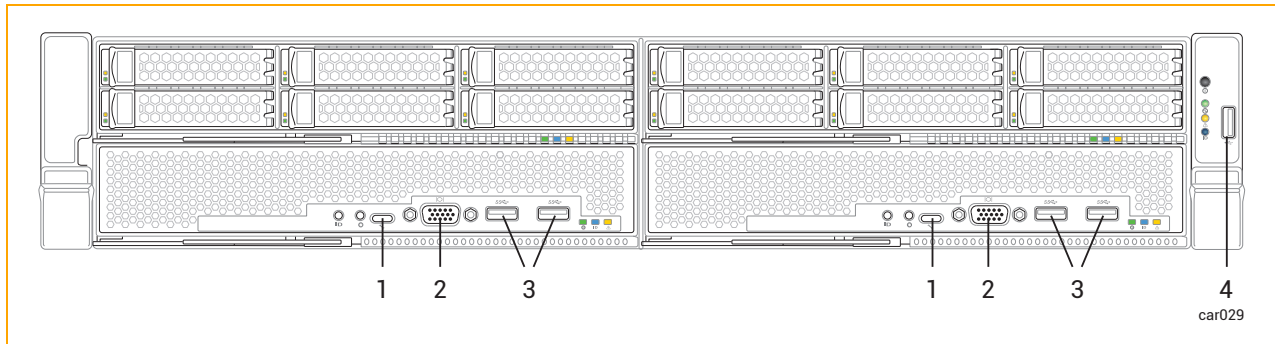

1	Debug ports (2)	3	USB 3.0 ports (4)
2	VGA (monitor port) (2)	4	USB 2.0 port (1)

Figure 1-4: System Ports: Rear

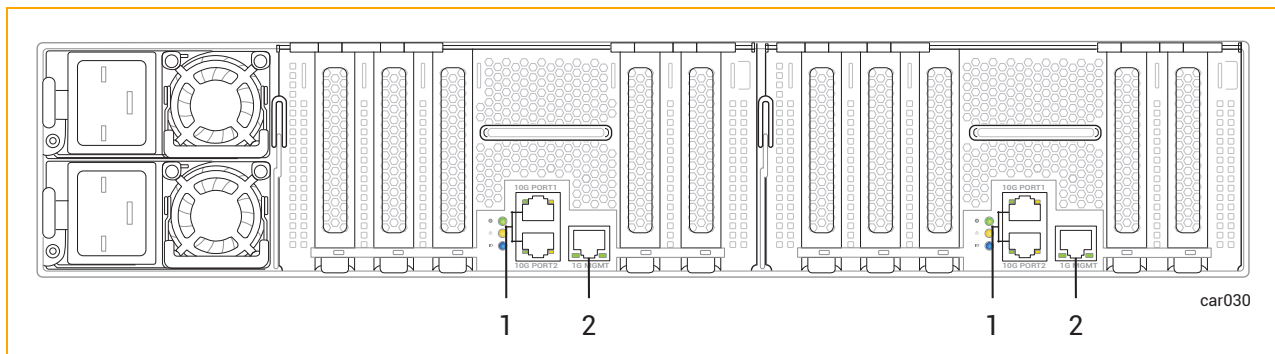

1	10G ports (4)
2	1G MGMT ports (2)

### Related Topics

- ["System Front" on page 17](#)
- ["System Rear" on page 18](#)

### System CRU Modules

A ztC Endurance system contains customer-replaceable unit (CRU) modules, which allow on-site personnel to easily remove and replace faulty components with minimal training or tools. These CRU modules are:

- [Compute module](#) and its [DIMMs](#)
- [Storage module](#) and its [disk drives](#)

- [I/O module](#) and its [PCIe adapters](#)
- [PSUs](#)

### Related Topics

- "System Front" on page 17
- "System Rear" on page 18
- "Removing and Replacing System Components" on page 97
- "System Specifications" on page 287

### Compute Module

A ztC Endurance system contains two compute modules: compute module A and compute module B. [Figure 1-1](#) shows the location of each compute module in a system.

A compute module is a [2U](#) component with processors, DIMMs, BIOS, BMC, fans, and other technology to boot and run the ztC Endurance system.

[Figure 1-5](#) shows an individual compute module. Each compute module provides:

- Ports, including one VGA port and two USB 3.0 ports. See "[System Ports](#)" on page 19. (The UART USB-C connector, known as the debug port, is used only by Penguin Solutions Customer Service for debugging.)
- An ID button, which activates the ID LED on the control-panel ear. See "[Status LEDs](#)" on page 86.
- An NMI button. See "[Using the NMI Button](#)" on page 96.
- Status LEDs, which indicate the status of the compute module. See "[Status LEDs](#)" on page 86.
- DIMMs, which provide the system's random-access memory (RAM). See "[Replacing, Adding, and Upgrading Memory](#)" on page 106.

Figure 1-5: Compute Module

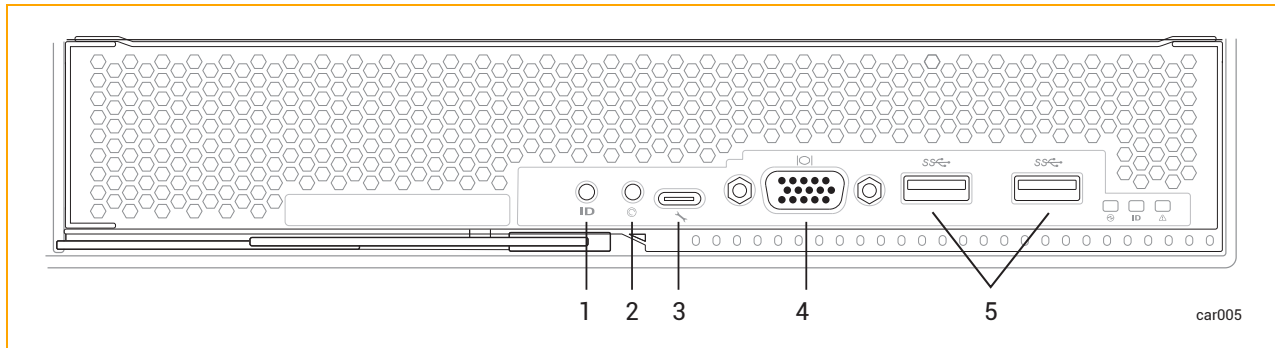

1	ID button	4	VGA port
2	NMI button	5	USB 3.0 port (x2)
3	Debug port		

### Related Topics

- ["System Front" on page 17](#)
- ["Planning a Site for ztC Endurance Systems" on page 35](#)
- ["Removing and Replacing a Compute Module" on page 103](#)
- ["System Specifications" on page 287](#)

### Memory in ztC Endurance Systems

Read this topic before you add or replace dual in-line memory modules (DIMMs) in a ztC Endurance system.

#### Cautions:



1. Penguin Solutions supports only the configurations described in this topic. Unsupported configurations may lead to system instability or failure.
2. For ztC Endurance systems operating in the low-voltage range, total memory must not exceed 256 GB. See ["System Specifications" on page 287](#) for more information about low-voltage systems.

**Précautions:**

1. Penguin Solutions ne prend en charge que les configurations décrites dans ce sujet. Les configurations non prises en charge peuvent entraîner une instabilité ou une défaillance du système.
2. Pour les ztC Endurance systèmes fonctionnant dans la gamme basse tension, la mémoire totale ne doit pas dépasser 256 Go. Consultez "[System Specifications](#)" on [page 287](#) pour plus d'informations sur les systèmes basse tension.

**Memory Components in Each Compute Module**

Table 1-1 lists the memory components in each compute module.



**Notice:** In a ztC Endurance 31x0 system, the eight DIMM slots next to the empty socket cannot contain DIMMs.

**Table 1-1: Memory Components**

Model	Processors	Sockets	DIMM Slots	Minimum Number of DIMMs	Maximum Number of DIMMs
31x0	1	2	16	1	4
51x0	2	2	16	2	8
71x0	2	2	16	4	16

Figure 1-6 shows the area of a compute module that contains memory components. Specifically, the figure shows the two processors, each installed in a socket, and the location of each DIMM slot.

Figure 1-6: Location of Memory Components in a Compute Module

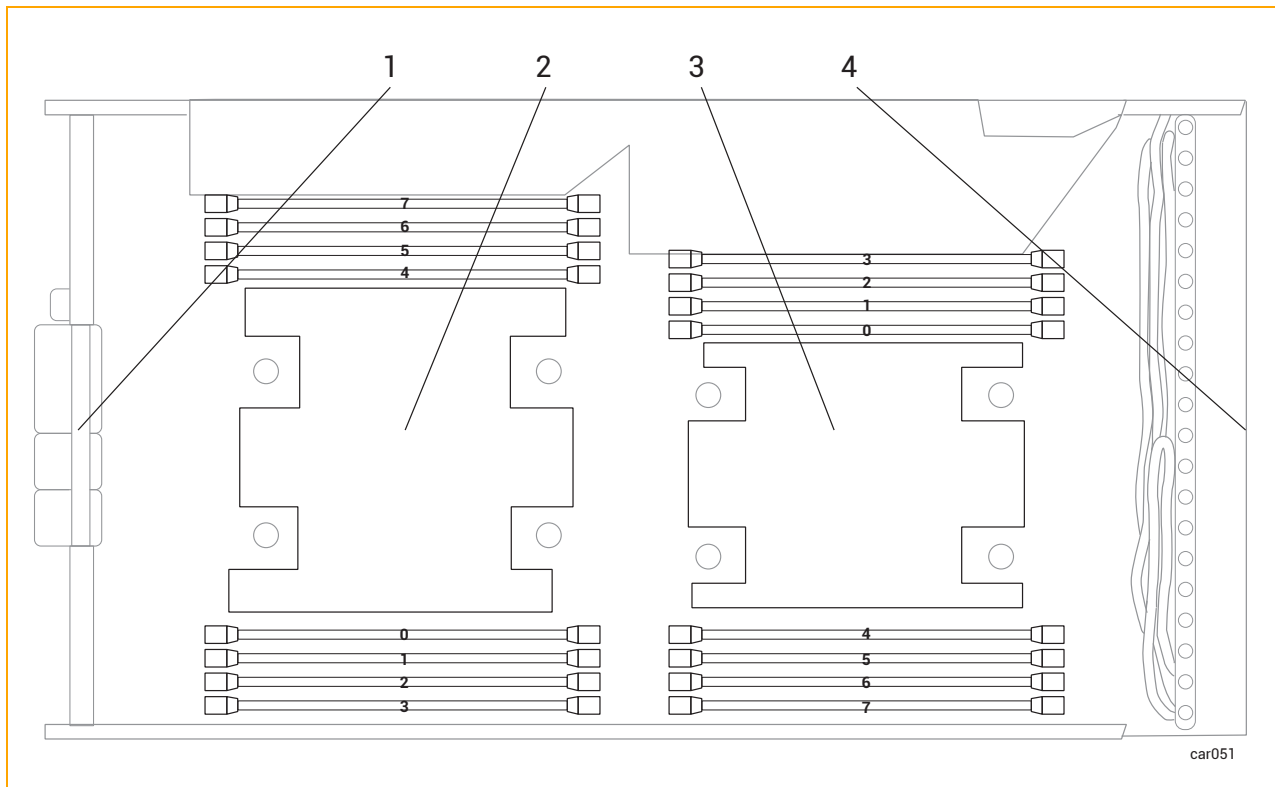

1	Rear of compute module	3	Processor 1
2	Processor 0	4	Front of compute module

### Memory in ztC Endurance 31x0 Systems

Table 1-2 shows a representation, starting from the front of the compute module, of DIMM locations for supported ztC Endurance 31x0 configurations. An "X" indicates the presence of a DIMM; all other DIMM slots are empty.

 **Note:** Table 1-2 does not show the DIMM slots that are next to the empty socket.

Table 1-2: Memory in ztC Endurance 31x0 Systems

	ZEN31x0-64	ZEN31x0-128	ZEN31x0-256
Slot 7			

	ZEN31x0-64	ZEN31x0-128	ZEN31x0-256
Slot 6		X	X
Slot 5			
Slot 4			X
<b>Processor 0</b>			
Slot 0	X	X	X
Slot 1			
Slot 2			X
Slot 3			

### Memory in ztC Endurance 51x0 Systems

Table 1-3 shows a representation, starting from the front of the compute module, of DIMM locations for supported ztC Endurance 51x0 configurations. An "X" indicates the presence of a DIMM; all other DIMM slots are empty.

**Table 1-3: Memory in ztC Endurance 51x0 Systems**

	ZEN51x0-128			ZEN51x0-256		ZEN51x0-512	
Slot 7	Slot 3						
Slot 6	Slot 2			X		X	X
Slot 5	Slot 1						
Slot 4	Slot 0		X		X	X	X
<b>Processor 0</b>	<b>Processor 1</b>						
Slot 0	Slot 4	X		X		X	X
Slot 1	Slot 5						
Slot 2	Slot 6				X	X	X
Slot 3	Slot 7						

## Memory in ztC Endurance 71x0 Systems

Table 1-4 shows a representation, starting from the front of the compute module, of DIMM locations for supported ztC Endurance 71x0 configurations. An "X" indicates the presence of a DIMM; all other DIMM slots are empty.

**Table 1-4: Memory in ztC Endurance 71x0 Systems**

	ZEN71x0-256			ZEN71x0-512		ZEN71x0-1024	
Slot 7	Slot 3					X	X
Slot 6	Slot 2	X		X	X	X	X
Slot 5	Slot 1					X	X
Slot 4	Slot 0		X	X	X	X	X
<b>Processor 0</b>	<b>Processor 1</b>						
Slot 0	Slot 4	X		X	X	X	X
Slot 1	Slot 5					X	X
Slot 2	Slot 6		X	X	X	X	X
Slot 3	Slot 7					X	X

### Related Topics

- ["Replacing, Adding, and Upgrading Memory" on page 106](#)
- ["Compute Module" on page 21](#)
- ["Hardware Page" on page 245](#)

### Storage Module

A ztC Endurance system contains two storage modules: storage module A and storage module B.

Figure 1-1 shows the location of each storage module in a system.

Figure 1-7 shows an individual storage module. Each storage module provides:

- Six slots for disk drives. For additional information about disk drives, see:
  - ["System Specifications" on page 287](#) for information about the supported disk drives.
  - ["Disk Drives" on page 27](#) for information about disk-drive configuration and numbering.
  - ["Internal Disk Drive Problems and Solutions" on page 95](#) for troubleshooting information.
  - ["Removing and Inserting a Disk Drive" on page 114](#) for maintenance information.
- Status LEDs, which indicate the status of the storage module. See ["Status LEDs" on page 86](#).

**Figure 1-7: Storage Module**

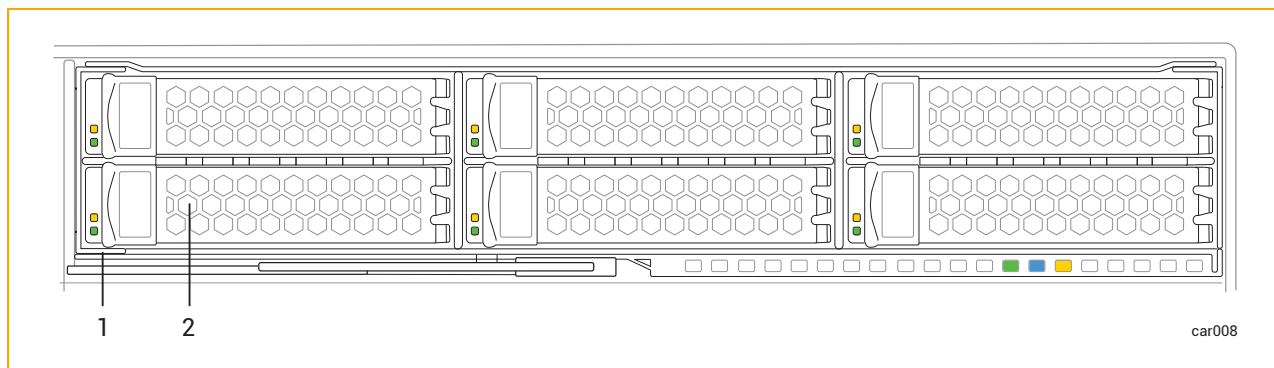

- |   |                                      |
|---|--------------------------------------|
| 1 | Storage module                       |
| 2 | Disk drive slot with disk drive (x6) |

### Related Topics

- ["System Front" on page 17](#)
- ["Planning a Site for ztC Endurance Systems" on page 35](#)
- ["Removing and Replacing a Storage Module" on page 112](#)

### Disk Drives

When you receive your system from the manufacturer, disk drives that were ordered at the same time the system was ordered are already installed. To install additional disk drives, be sure to read ["Installing Additional Disk Drives" on page 28](#) and ["Important Considerations When Installing Disk Drives" on page 29](#) before you read ["Removing and Inserting a Disk Drive" on page 114](#).

See ["System Specifications" on page 287](#) for information about the supported disk drives.

## Understanding Disk-Drive Numbering

Storage module A and storage module B each contain six disk-drive slots, for a total of 12 per system. The slots are labeled 1 through 6 on each storage module, as shown in [Figure 1-8](#).

**Figure 1-8: Disk-Drive Slot Numbering**

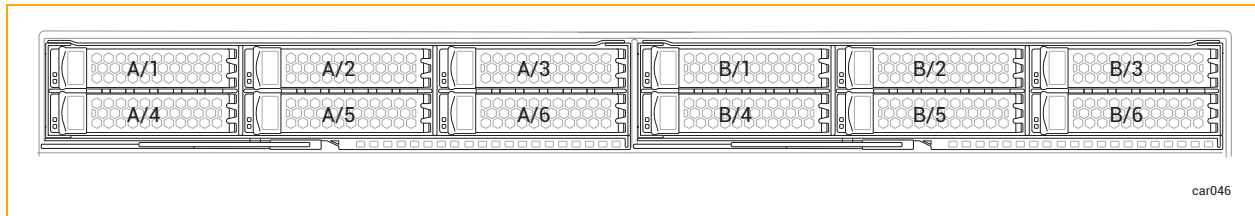

The physical disk-drive slot numbering corresponds to the software numbering. For example, disk-drive slot 1 corresponds to slots A/1 and B/1 in the software, disk-drive slot 2 corresponds to slots A/2 and B/2, and so on.

You can view information about the disk drives from "[Hardware Page](#)" on [page 245](#) of the ztC Endurance console and from your operating-system software.

## Installing Additional Disk Drives

Install additional disk drives in your system in the order shown in [Table 1-5](#). For example, if you are adding two disks to a system that already contains disks in slots A/1 and B/1, install the two additional disks in slots A/2 and B/2, for a total of four disks in the system.

**Table 1-5: Disk-Drive Installation Order**

Number of Disks	Storage Module A	Storage Module B
2	Slot 1	Slot 1
4	Slots 1, 2	Slots 1, 2
6	Slots 1, 2, 3	Slots 1, 2, 3
8	Slots 1, 2, 3, 4	Slots 1, 2, 3, 4
10	Slots 1, 2, 3, 4, 5	Slots 1, 2, 3, 4, 5
12	Slots 1, 2, 3, 4, 5, 6	Slots 1, 2, 3, 4, 5, 6

## Important Considerations When Installing Disk Drives

Before you install disk drives, consider the following:

- The boot drive must be installed in slot 1.
- A storage module can contain different disk-drive models. However, you must install identical disk-drive models in matching storage module A and B slots. For instance, if you install a 1.6 TB disk drive in slot 1 of storage module A, you must install a 1.6 TB disk drive in slot 1 of storage module B.
- Make sure all disk drives are correctly inserted as described in ["To insert a disk drive" on page 115](#).

### Related Topics

- ["Removing and Inserting a Disk Drive" on page 114](#)
- ["Internal Disk Drive Problems and Solutions" on page 95](#)
- ["Storage Module" on page 26](#)

### I/O Module

A ztC Endurance system contains two I/O modules: I/O module A and I/O module B. [Figure 1-2](#) shows the location of each I/O module in a system.

[Figure 1-9](#) shows an individual I/O module. Each I/O module provides:

- Ethernet ports. See ["System Ports" on page 19](#).
  - One 1G (RJ45) port for an out-of-band management network
  - Two 10G (RJ45) ports
- Status LEDs, which indicate the status of the I/O module. See ["Status LEDs" on page 86](#).
- Five PCIe 4.0 slots for half-height PCIe adapters. For additional information about PCIe adapters, see:
  - ["System Specifications" on page 287](#) for information on the supported PCIe adapters.
  - ["PCIe Adapters" on page 30](#) for information about PCIe-adapter configuration and numbering.
  - ["Removing and Installing a PCIe Adapter" on page 122](#) for maintenance information.

Figure 1-9: I/O Module

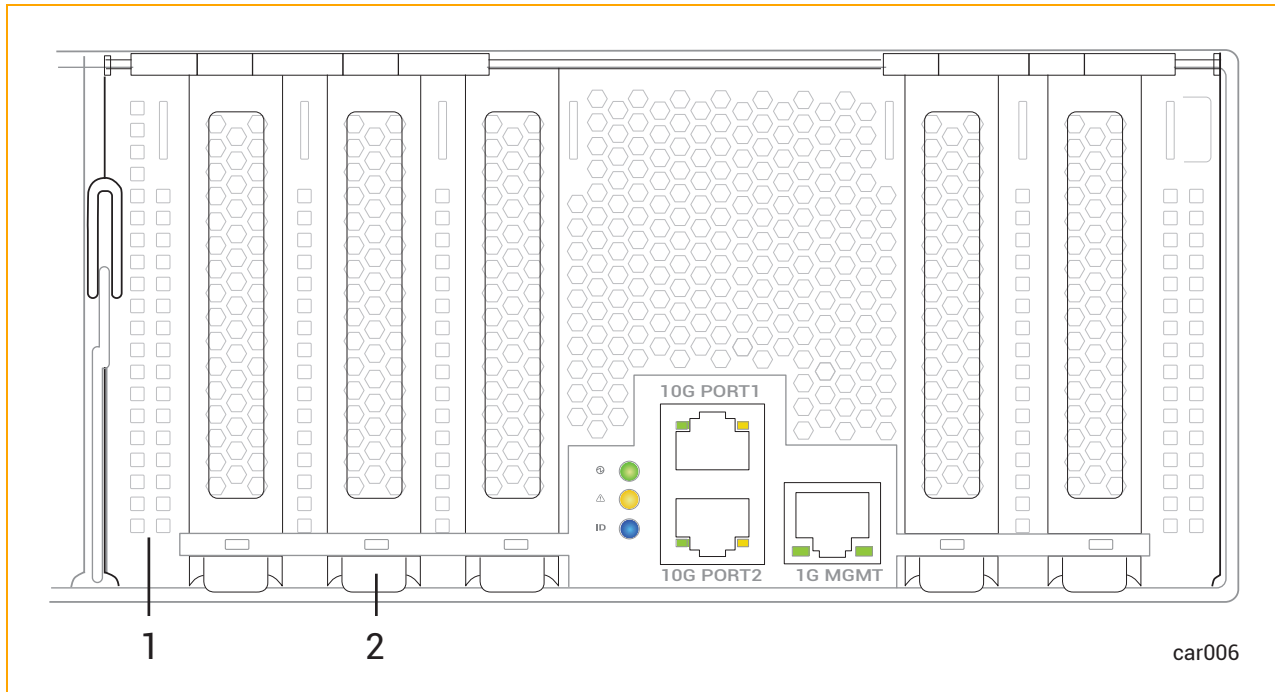

1	I/O module
2	PCIe adapter slot (x5)

### Related Topics

- ["System Rear" on page 18](#)
- ["Planning a Site for ztC Endurance Systems" on page 35](#)
- ["Removing and Replacing an I/O Module" on page 119](#)
- ["Hardware Page" on page 245](#)
- ["System Reference Information" on page 287](#)
- ["System Specifications" on page 287](#)

### PCIe Adapters

When you receive your system from the manufacturer, PCIe adapters that were ordered at the same time the system was ordered arrive pre-installed. To install additional PCIe adapters, be sure to read the following before you read ["Removing and Installing a PCIe Adapter" on page 122](#)

- ["Understanding PCIe-Slot Numbering" on page 31](#)
- ["Installing Additional PCIe Adapters" on page 32](#)

- ["Important Considerations When Installing PCIe Adapters"](#) on page 32
- ["Valid PCIe Configurations"](#) on page 33

See ["System Specifications"](#) on page 287 for information about the supported PCIe adapters.

### Understanding PCIe-Slot Numbering

I/O module A and I/O module B each contain five PCIe adapter slots, for a total of ten per system. The slots are labeled 1 through 5 on each I/O module, as shown in [Figure 1-10](#). Each I/O module also contains an embedded dual-port 10G adapter.

**Figure 1-10: PCIe-Adapter Physical Slot Numbering**

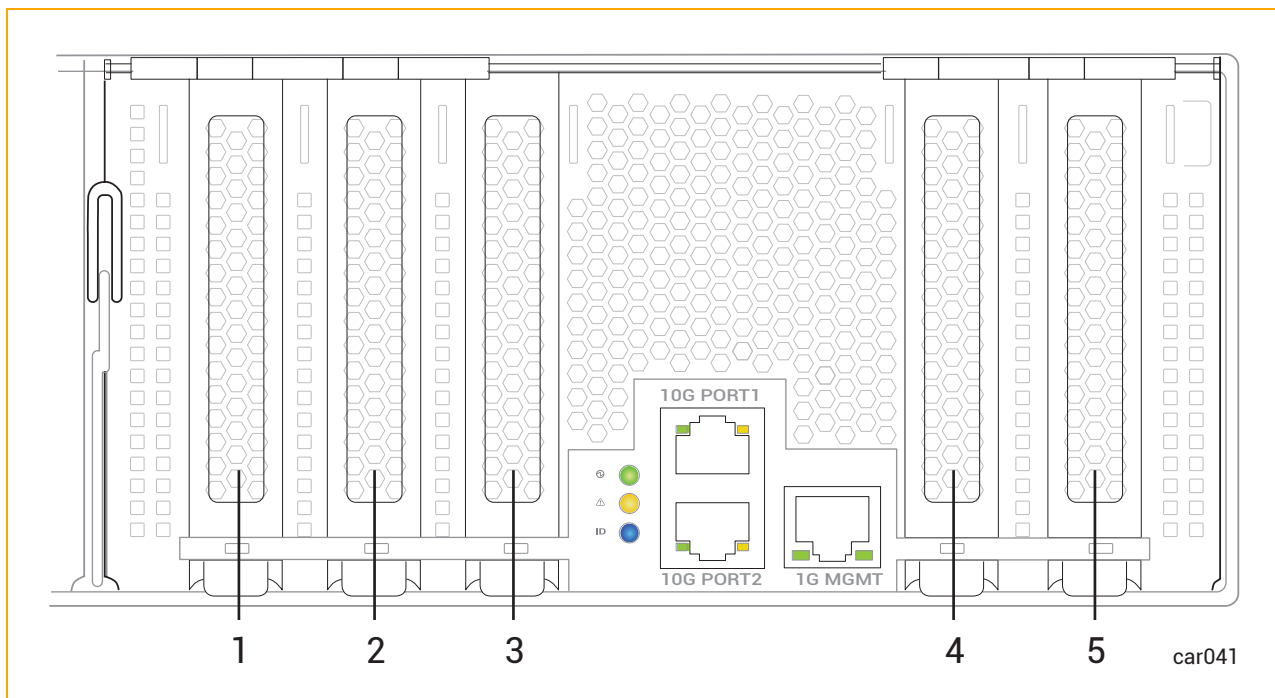

1	PCIe slot 1	4	PCIe slot 4
2	PCIe slot 2	5	PCIe slot 5
3	PCIe slot 3		

You can view information about the PCIe adapters from ["Hardware Page"](#) on page 245 of the ztC Endurance console and from your operating-system software.

- For PCIe slots 1 through 5, the physical PCIe slot numbering corresponds to the software numbering. For example, PCIe slot 1 corresponds to slots A/1 and B/1 in the software, PCIe slot

2 corresponds to slots A/2 and B/2, and so on.

- The embedded dual-port 10G adapters appear in the software as slots A/6 and B/6.

### Installing Additional PCIe Adapters

Install additional PCIe adapters in your system in the order shown in [Table 1-6](#). For example, if you are adding two PCIe adapters to a system that already contains PCIe adapters in slots A/1 and B/1, install the two additional PCIe adapters in slots A/2 and B/2, for a total of four PCIe adapters in the system.

**Table 1-6: PCIe-Adapter Installation Order**

Number of Adapters	I/O Module A	I/O Module B
2	Slot 1	Slot 1
4	Slots 1, 2	Slots 1, 2
6	Slots 1, 2, 3	Slots 1, 2, 3
8	Slots 1, 2, 3, 4	Slots 1, 2, 3, 4
10	Slots 1, 2, 3, 4, 5	Slots 1, 2, 3, 4, 5

### Important Considerations When Installing PCIe Adapters

Before you install PCIe adapters, consider the following:

- Use only PCIe adapters approved by Penguin Solutions. Before approving a PCIe adapter, Penguin Solutions thoroughly tests it to make sure that it interacts properly with ztC Endurance systems, including I/O redundancy with a duplexed partner if an active PCIe adapter or I/O module fails or is removed from service. Customers who have attempted to use inadequately tested PCIe adapters in their systems have frequently experienced problems that proved difficult to isolate and diagnose and resulted in delayed projects.
- Thoroughly test any new PCIe adapter, including adapters sold or approved by Penguin Solutions, with your applications in a test environment before using it in a production environment.
- An I/O module can contain different PCIe adapter models. However, you must install identical PCIe adapter models in matching I/O module A and B slots. For instance, if you install an Intel X550-T2 PCIe adapter in slot 1 of I/O module A, you must install an Intel X550-T2 PCIe adapter in slot 1 of I/O module B.

## Valid PCIe Configurations

Table 1-7 describes valid PCIe adapter configurations for each ztC Endurance I/O module. To interpret the table, read it from left to right.



**Note:** Contact your authorized Penguin Solutions service representative if you have questions about the models supported by your ztC Endurance system.

**Table 1-7: Valid PCIe Adapter Configurations for Windows ztC Endurance Systems**

ztC Endurance Model	Maximum Number of Each Adapter Type Allowed Per I/O Module			Maximum Number of Total Adapters Allowed Per I/O Module
	XXV710 Dual 25 Gbps	QLE2770 Single 32 Gbps	X550 or X710 Dual 10 Gbps	
Low-voltage 31x0	Not supported	0	3	3
		1	1	2
Low-voltage 51x0	Not supported	0	3	3
		1	1	2
31x0	Not supported	1	3	3
51x0	2	2	4	4
71x0	2	2	5	5

### Related Topics

- ["Removing and Installing a PCIe Adapter" on page 122](#)
- ["I/O Module" on page 29](#)
- ["Hardware Page" on page 245](#)
- ["System Specifications" on page 287](#)

### PSUs

A ztC Endurance system contains two power supply units (PSUs): PSU A and PSU B. [Figure 1-2](#) shows the location of each PSU in a system.

Figure 1-11 shows an individual PSU. Each PSU includes a status LED, which indicates the status of the unit. See ["Status LEDs"](#) on page 86.

**Figure 1-11: Power Supply Unit (PSU)**

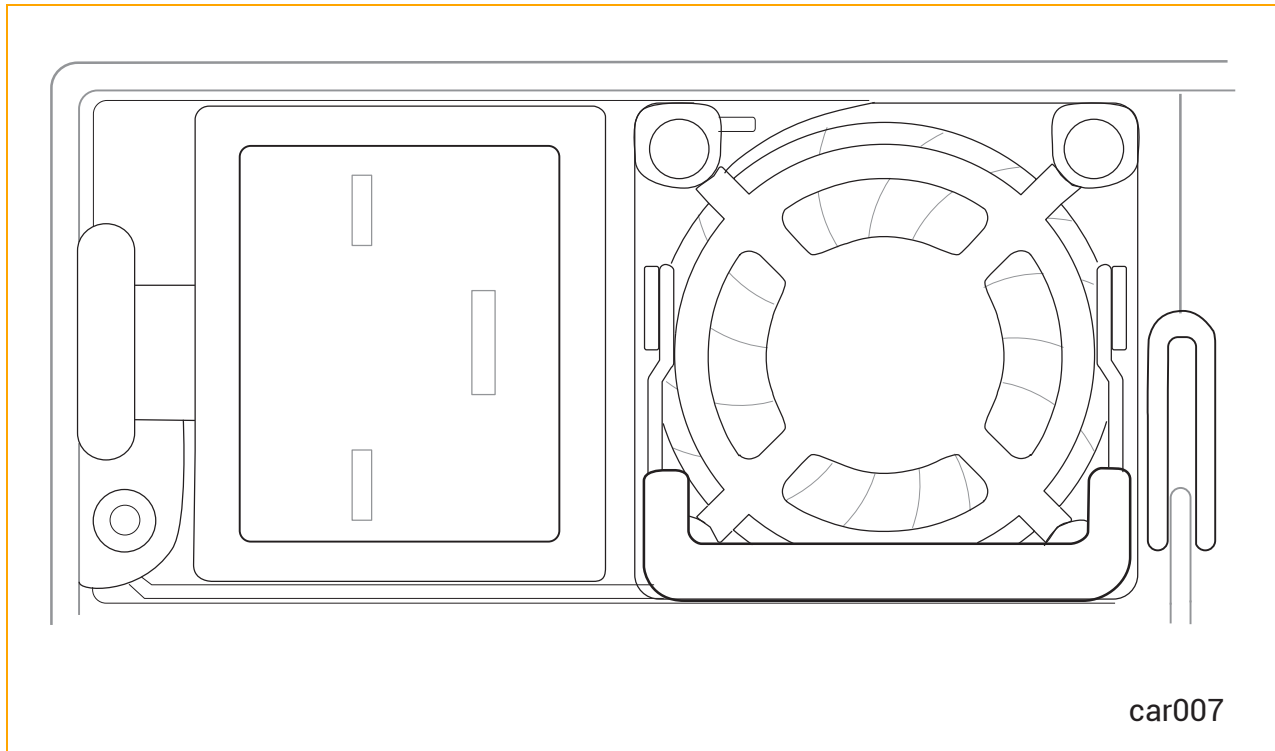

### Related Topics

- ["System Rear"](#) on page 18
- ["Planning a Site for ztC Endurance Systems"](#) on page 35
- ["Removing and Replacing a PSU and Power Cords"](#) on page 127
- ["System Power"](#) on page 82
- ["Standby Power"](#) on page 81
- ["System Reference Information"](#) on page 287
- ["System Specifications"](#) on page 287

### Peripheral Components

Penguin Solutions supplies a mouse and keyboard for your ztC Endurance system.

For site-planning information for the mouse and keyboard, see ["Site Planning for Peripheral Components"](#) on page 48.

For information about connecting the mouse and keyboard, see [Connecting Peripherals](#).

# 2

## Chapter 2: Planning a Site for ztC Endurance Systems

### Notes:



1. See "Safety Notices" on page 50 for a list of important safety notices that you should review as part of your site planning.
2. All regulatory notices are provided in *Compliance Information for Stratus Products (R002G)*, which is available on StrataDOC at [https://stratadoc.stratus.com/compliance\\_info/Compliance\\_Information\\_for\\_Stratus\\_Products.htm](https://stratadoc.stratus.com/compliance_info/Compliance_Information_for_Stratus_Products.htm)

Site planning for ztC Endurance systems includes:

- "Site Planning Checklist" on page 36

Reviewing the site-planning checklist for a summary of questions you might need to consider when planning for the installation of a ztC Endurance system.

- "Electrical Power Planning" on page 38

Providing electrical power sources that meet the requirements of the system and optional components, including the purchase of user-supplied power-distribution units (PDUs) and uninterruptible power supplies (UPSes).

- "Space Planning" on page 44

Providing adequate space for the system or cabinet and for a desk or table to accommodate components outside a cabinet. Also providing enough space for servicing the systems and components.

Providing an environment that meets the system's requirements for ambient temperature and air quality.

- "Cabinet Requirements" on page 45

Providing a cabinet that meets the system's requirements and provides sufficient space for all components, including user-supplied PDUs and UPSes.

- "Site Planning for Peripheral Components" on page 48

Providing a monitor, keyboard, and mouse (if applicable) that meet the system's requirements.

Providing for the electrical, cooling, power, and space needs of any peripheral components.

For additional documentation related to the ztC Endurance system, see the StrataDOC (ztC Endurance Version) page at <https://ztcendurancedoc.stratus.com>.

During the site planning and preparation processes, work closely with your facilities group or contractor to determine space, power, and environmental requirements. Enlist their help to provide a suitable location with sufficient alternating current (AC) power, heating, ventilation, and air conditioning (HVAC) capabilities, and network and telephone connections.

If the system is covered by a service agreement and you need help with site planning, contact your authorized Penguin Solutions service representative. If you have a contract with your authorized Penguin Solutions service representative to install the system, contact them after you have prepared the installation site and moved the system to the site. For more information about your authorized Penguin Solutions service representative, see "Getting Help" on page 293 or the **Penguin Solutions Customer Service** page at <https://www.penguinolutions.com/en-us/support>.

See "System Specifications" on page 287 for the specifications of the ztC Endurance systems.

## Site Planning Checklist

Referring to the information in this document, answer the following questions:

### Planning for ActiveService Network Connectivity

- Will the ztC Endurance system connect to the Stratus ActiveService Network (ASN), allowing the system to automatically report problems to your authorized Penguin Solutions service representative?
- To allow connections to the ASN to report system health and events on your system, can you connect at least one pair of partnered Ethernet ports, one from each I/O module in the system, to a network that has Internet access?
- To optionally enable Penguin Solutions Customer Service or your authorized Penguin Solutions service representative to access the system to remotely diagnose, troubleshoot, and resolve problems online, can you connect the Ethernet port of the Baseboard Management Controller

(BMC) in each module to a network that has Internet access? (The BMCs can communicate with the ASN even when the host operating system is not running or is unresponsive.)

### Planning for Network Connectivity

- Each ztC Endurance system contains four embedded 10-gigabit Ethernet (GbE) ports, two in each I/O module, for connection to business networks. In addition, each system contains two embedded 1GbE ports that are dedicated to the BMCs for out-of-band management. How many embedded Ethernet ports will you connect to a network, and how many optional, non-embedded Ethernet PCIe adapters will you need to add to provide additional Ethernet bandwidth?
- How many embedded or non-embedded Ethernet ports in the system will require access to the Internet?

### Planning AC Power

- Will you provide power to both sides of the system through a pair of PDUs?
- Will you protect the system power with a UPS?
- What optional components will you use?
- What are the AC power requirements of the system, including all optional components?
- What are the lengths and types of the power cords that are provided for the PDUs or system, and optional components?
- What type of AC receptacles do you need to provide?
- Is the AC power service wired properly?

### Planning Space for the System

- If applicable, provide a table or desk for the monitor, keyboard, and mouse.
- Will the system and any external components fit where you plan to place them?
- What is the height of the cabinet you will use, and what is the total height of the systems and components that will be installed in the cabinet? Will the items fit into the cabinet? What components will be located outside the cabinet?
- What are the lengths and types of the interface and communications cables that will connect to the system?
- Have you created a sketch of how you plan to arrange the system at the installation site? Consider the available cable lengths, the placement of external devices, and the location of network and voice communication connections.

On the sketch, show the following:

- Location of the system and its external components
- Power cords, and telephone and interface cables
- Locations of AC power receptacles, Ethernet jacks, switches, and hubs



**Note:** Make sure that all cords and cables are long enough to reach between their respective components and connectors. Route all cables out of the way of foot traffic.

## Working with Other Groups

- Have you provided your facilities group and contractors with the sketch of how you plan to arrange the system and copies of the following?
  - ["Redundant Power Sources" on page 38](#)
  - ["AC Power and HVAC Service Requirements" on page 39](#)
  - ["Electrical Circuit and Wiring Information" on page 133](#)
  - Any notes you have about site planning
- Have you reviewed and discussed the requirements with the facilities personnel and contractors to ensure that all site modifications are understood and implemented?

If you have any questions about the number and types of components, contact your Penguin Solutions account representative or distributor.

## Electrical Power Planning

For information about planning appropriate AC electrical power for the system and its peripheral components, see:

- ["Redundant Power Sources" on page 38](#)
- ["AC Power and HVAC Service Requirements" on page 39](#)
- ["Electrical Power Connections" on page 39](#)
- ["Power Cords" on page 40](#)
- ["Grounding Requirements" on page 43](#)

## Redundant Power Sources

ztC Endurance systems require at least two separate and independent AC power sources—an *A-side* power source and a *B-side* power source—that provide power to the system's power receptacles. Either source must be capable of continuing to provide power if power to the other source is lost.

The A-side power source provides power to the top power-supply unit (PSU) in the system. The B-side power source provides power to the bottom PSU.

Each PSU in the system is capable of providing power to the entire system. When both PSUs have electrical power, they share the load of the system components; however, if one PSU fails or if power is lost to either the A- or B-side power source, the remaining PSU can pick up the full load of the system.

Although either PSU is capable of powering the ztC Endurance system, it is still important to separate power sources as much as possible to maximize redundancy. Furthermore, if you connect user-supplied peripheral components that also contain two PSUs, attach each side to the independent A- and B-side power sources. For components that do not require two sources of power, such as monitors, management PCs, or other user-supplied components, you typically attach these components to the A-side power source.

If provided by the customer, a pair of PDUs may supply power to multiple systems and components in a cabinet. The top PDU in the cabinet typically provides A-side power. The bottom PDU typically provides B-side power.

## AC Power and HVAC Service Requirements

Use the specifications in the "AC Power" section of ["System Specifications" on page 287](#) to determine AC power and HVAC requirements for the ztC Endurance system. Because the ztC Endurance PSUs balance the load of the system components, the total power requirement for either side of the system should not exceed the system specifications listed in the "AC Power" section.

For any optional components, see the included documentation to obtain the nominal input line voltage (volts AC) and frequency (Hz) required.



**Notice:** A branch circuit breaker with ground fault protection must allow a minimum of 3.5 milliamperes (mA) leakage current for each power cord.

See ["System Specifications" on page 287](#) for additional ztC Endurance system specifications.

## Electrical Power Connections

Provide two AC power sources that are as electrically independent of each other as the installation site allows. At a minimum, the two power sources must be powered by separate circuit breakers (maximum of 20A) to AC power and, if possible, be independent of each other beyond that level. The more electrical separation between the two power sources, the less likely they will both fail at the same time. Due to redundancy in ztC Endurance systems, power to either side of the system keeps the system in operation.

[Figure 2-1](#) shows an example of how to connect a ztC Endurance system directly to two separate AC power sources.

Figure 2-1: Connecting a System Directly to AC Power

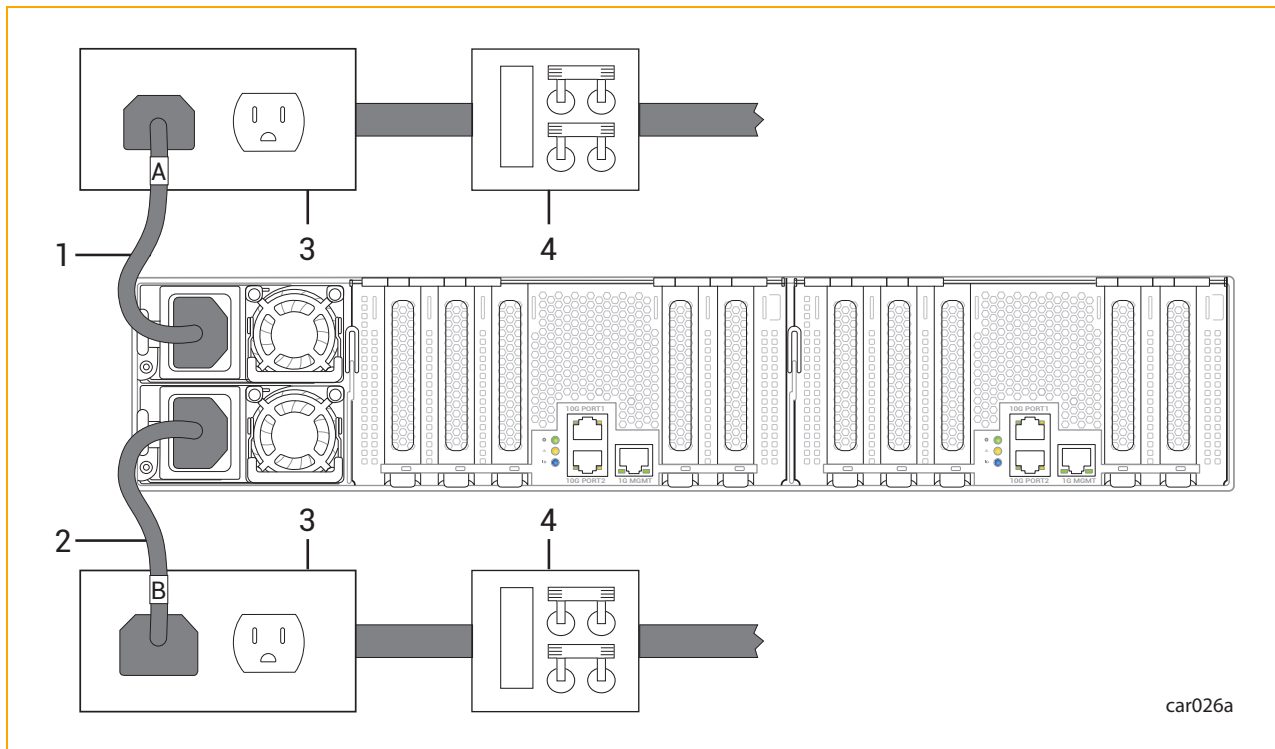

1	A-side power cord	3	AC power outlets
2	B-side power cord	4	AC power (mains) distribution circuit breakers (maximum of 20A)

### Related Topics

- ["PSUs" on page 33](#)
- ["Removing and Replacing a PSU and Power Cords" on page 127](#)
- ["Power Cords" on page 40](#)
- [Connecting the System to Electrical Power](#)

### Power Cords

Penguin Solutions supplies tested and approved AC power cords for the ztC Endurance system and for Penguin Solutions-supplied peripheral components.

**Cautions:**

1. Place all power cords out of the way of foot traffic.
2. All models and both PSUs must operate in the same voltage range (either 100-127V or 200-240V). Select power cords to maintain a uniform voltage range and local installation requirements.

**Précautions:**

1. Éloigner tous les cordons d'alimentation du passage.
2. Tous les modèles et les deux blocs d'alimentation doivent fonctionner dans la même plage de tension (100-127V ou 200-240V). Sélectionnez les cordons d'alimentation pour maintenir une plage de tension uniforme et respecter les exigences locales d'installation.

Table 2-1 lists the available power cords that connect ztC Endurance systems directly to an AC power source (not to a PDU or to a UPS).



**Notice:** In Table 2-1, power cords with a locale of "United States" also support countries that use NEMA connectors and are made with American Wire Gauge (AWG) cordage approved for use in North America. Refer to UL 62 and CSA C22.2, No. 49. All other power cords are made with international cordage and are intended for use in the specified countries, and in other countries that use that standard.

**Table 2-1: Power Cords: ztC Endurance Systems to AC Power**

Marketing ID	Plug Type	Rating	Length	Locale
ZEN-PWR-211	IEC 60320 C19 to CEE 7 VII	16A/250V	8.2 ft (2.5m)	Europe, Korea
ZEN-PWR-212	IEC 60320 C19 to IEC/EN 60309	16A/250V	8.2 ft (2.5m)	United Kingdom, Singapore
ZEN-PWR-213	IEC 60320 C19 to SAA/3/15	15A/250V	8.2 ft (2.5m)	Australia
ZEN-PWR-214	IEC 60320 C19 to IND/3/16 IS694	16A/250V	8.2 ft (2.5m)	India

ZEN-PWR-215	IEC 60320 C19 to JIS C8303 6/15AJ	15A/250V	8.2 ft (2.5m)	Japan
ZEN-PWR-216	IEC 60320 C19 to GB2099/GB1002	16A/250V	8.2 ft (2.5m)	China
ZEN-PWR-217	IEC 60320 C19 to NBR14136	16A/250V	8.2 ft (2.5m)	Brazil
ZEN-PWR-218	IEC 60320 C19 to CNS 690	15A/250V	8.2 ft (2.5m)	Taiwan
ZEN-PWR-221	IEC 60320 C19 to NEMA 6-20	20A/250V	8.2 ft (2.5m)	United States
ZEN-PWR-225	IEC 60320 C19 to ZA/3 SABS 164-1	16A/250V	8.2 ft (2.5m)	South Africa
ZEN-PWR-226	IEC 60320 C19 to NEMA L6-20	20A/250V	8.2 ft (2.5m)	Japan
ZEN-PWR-220 (low voltage)	IEC 60320 C19 to 498GJTW	15A/125V	8.2 ft (2.5m)	Japan and Taiwan <div style="border: 1px solid #8B4513; padding: 10px; margin-top: 10px;"> <p><b>Notice:</b> This power cord is not supported for low-voltage ztC Endurance 5110 systems that contain 512 GB of memory.</p> </div>
ZEN-PWR-222 (low voltage)	IEC 60320 C19 to NEMA 5-20	20A/125V	8.2 ft (2.5m)	United States

				<div style="border: 1px solid #8B4513; padding: 10px;"> <p><b>Notice:</b> This power cord is not supported for low-voltage ztC Endurance 5110 systems that contain 512 GB of memory.</p> </div>
--	--	--	--	---

 **Note:** When ordering individual power cords as spares or upgrades, the product's Marketing ID should be followed by -P.

**Related Topics**

- ["System Specifications" on page 287](#)
- ["PSUs" on page 33](#)
- ["Removing and Replacing a PSU and Power Cords" on page 127](#)
- [Connecting the System to Electrical Power](#)
- ["Electrical Power Connections" on page 39](#)

**Grounding Requirements**

 **Warning:** Incorrect grounding can cause severe personal injury and extensive equipment damage.

 **Avertissement:** Une mise à la terre incorrecte peut provoquer des blessures graves et endommager sérieusement l'équipement.

The ztC Endurance system obtains its protective earth (PE) ground through the power cord. See ["Grounding Considerations" on page 133](#) for a more complete discussion of ztC Endurance system grounding.

## Space Planning

For information about planning sufficient space for a ztC Endurance system, see:

- ["Room Requirements" on page 44](#)
- ["Planning for Cables" on page 45](#)

## Room Requirements

To ensure that the installation site provides a properly equipped, cooled, and sized environment, make sure that the site:

- Provides clearances for air circulation, opening cabinet doors, removing cabinet panels, and servicing the system from the front and rear.

Locate the front and rear of the system at least 2.5 feet (ft) (0.76 meters (m)) away from walls and other obstructions.

- Maintains reasonable temperature and humidity levels, and has a thermometer and humidistat to monitor room temperature and humidity.

See ["AC Power and HVAC Service Requirements" on page 39](#) for detailed information about HVAC planning and ["System Specifications" on page 287](#) for detailed information about temperature and humidity requirements.

- Is as free as possible of airborne contamination (particulate and gaseous).



**Notice:** Due to the mission-critical nature of ztC Endurance servers, data centers housing the equipment should follow the guidelines of airborne contamination (particulate and gaseous) as outlined in the ASHRAE (TC) 9.9 documentation. Particulate matter to adhere to ISO 14644-1 Class 8. Gaseous contamination, such as sulfur or chlorine-bearing gases to adhere to ANSI/ISA-71.04-1985 Severity level G1.

Dust buildup in the system can impede air circulation and heat transfer, causing components to become less reliable as the ambient temperature rises.

Fans clogged by dust fail to expel hot air, causing circuit boards to overheat and fail.

Dust on circuit boards raises the temperature, thus reducing the component's mean time between failure (MTBF).

Dust circulating in the room increases the risk of fire within the room by providing potential combustible material within the environment.

Dust contamination on tape devices causes mis-reads and -writes, leading to failure of attempts to back up and restore data.

- Provides two electrically separate grounded AC wall outlets, within reach of the power cords from the system or PDUs, and, if used, UPS units. If the power cord must be hardwired, consult an electrician to plan the length of the power cord.
- Provides cutouts in the floor for routing cables, if the site has an elevated floor.
- Contains space for future expansion.



**Caution:** Do not place the system in an area of high electrostatic discharge. Static electricity may damage components. Do not locate components near transformers or other electromagnetic devices.



**Précaution:** Ne pas placer le système dans une zone de forte décharge électrostatique. L'électricité statique peut endommager les composants. Ne pas placer de composants à proximité de transformateurs ou d'autres appareils électromagnétiques.

See "[System Specifications](#)" on page 287 for the dimensions of system components.

## Planning for Cables

To accommodate cables from the system, make sure to provide:

- Ethernet jacks, switches, or hubs, as needed
- Two electrically separate grounded AC wall outlets, or a UPS and a wall outlet, within reach of the power cords from the system or PDUs, and additional outlets for any components that do not connect to a PDU
- AC wall outlets within reach of the power cords from optional components such as monitors, management PCs, or other users-supplied components; or use PDUs

Make sure that cables you plan to connect to the system are long enough to reach between the system and external components or connections. For information about specific cables and power cords, see the following topics:

- "[Power Cords](#)" on page 40
- "[Site Planning for Peripheral Components](#)" on page 48

## Cabinet Requirements

In general, consider the following factors during your site planning for systems in cabinets:

- Elevated Operating Ambient Temperature—If installed in a closed or multi-unit rack assembly, the operating ambient temperature of the rack environment may be greater than room ambient. Therefore, consideration should be given to installing the equipment in an environment compatible with the maximum ambient temperature (T<sub>ma</sub>) specified by the manufacturer.
- Reduced Air Flow—Installation of the equipment in a rack should be such that the amount of air flow required for safe operation of the equipment is not compromised.
- Mechanical Loading—Mounting of the equipment in the rack should be such that a hazardous condition is not achieved due to uneven mechanical loading.
- Circuit Overloading—Consideration should be given to the connection of the equipment to the supply circuit and the effect that overloading of the circuits might have on overcurrent protection and supply wiring. Appropriate consideration of equipment nameplate ratings should be used when addressing this concern.
- Reliable Earthing—Reliable earthing of rack-mounted equipment should be maintained. Particular attention should be given to supply connections other than direct connections to the branch circuit (for example, use of power strips).

Make sure that the cabinet meets the following requirements:

- The cabinet can support the weight of all of the components you plan to install in it. "[System Specifications](#)" on page 287 provides the weights of ztC Endurance system components. To determine the weight of any peripheral components, see the documentation included with those components.
- The cabinet contains two front and two rear vertical EIA rails, one in each corner of the cabinet, that have the universal hole pattern as defined in the EIA 310-D Section 1 specification.
- The front vertical rails extend at least 0.5 in. (1.27 centimeters (cm)) beyond the inside edge of the accessory leg, if present, to allow the mounting rails to be fitted.
- The distance between the front vertical rails and the inside of the front door is at least 3.0 in. (7.62 cm).
- The distance between the rear of the system chassis and the inside of the rear door is at least 6.0 in. (15.24 cm).
- The distance between the front and rear vertical rails is between 24 in. and 31.5 in. (60.96 cm and 80 cm, respectively).
- The vertical mounting rails have a 0.275 in. (7.0 mm) round or 0.375 in. (9.53 mm) square pattern, with a thickness between 0.063 in. - 0.105 in.

- The vertical mounting rails are plated, or some other method is used to ensure continuity for grounding between installed equipment.
- Cable-management brackets are provided to support and constrain data and power cords so that the cables do not interfere with air flow out of the rear of the modules, and so that the connectors do not disconnect or break.
- To prevent stray voltages, all components are grounded together through the vertical mounting rails to the cabinet frame, and then to local building ground. To ensure signal quality, use a grounding cable for local building ground.
- There is a plan for maintaining cables and wires to the cabinet by either running them under the floor or placing them overhead in an overhead cable tray.
- Air flows through the cabinet from front to back.
- Air does not recirculate within the cabinet.
- Filler panels cover any unused rack space to prevent air recirculation.
- Blockers are installed between the vertical mounting rails and the side panels at the rear of the cabinet.
- Vents are evenly distributed on the front and rear doors and make up at least 69% of the surface area.



**Caution:** The cabinet must have vented front and rear doors to prevent the system from overheating while in operation.



**Précaution:** L'armoire doit avoir des portes avant et arrière ventilées pour empêcher le système de surchauffer pendant le fonctionnement.

- The final installation conforms to all emission, immunity, safety, and other applicable regulations.



**Notice:** A ztC Endurance system allows you to install USB cables and USB flash drives in the front of the system, as well as various data and power cables in the rear of the system. The recommended clearance dimensions of 76 mm from front rails to the door, and 152 mm between the rear of the system chassis and the inside of the rear door, ensure that there are no clearance issues with the previously mentioned accessories or device. Although not recommended, a 1000 mm rack may be possible if the cabinet rails are skewed to the front, thus preventing use of accessories in the front of the system, while allowing more space for cabling in the rear.

Examples of recommended cabinets for system installation follow:

- With a vertical PDU installed, xU high x 31.5 in. (800 mm) wide x 47.2 in. (1200 mm) deep. For example: APC™ NetShelter™ SV AR2580-42U
- Without a PDU installed, xU high x 23.6 in. (600 mm) wide x 42.1 in. (1070 mm) deep. For example: APC NetShelter SX AR3104-24U

## Site Planning for Peripheral Components

Remember to plan for any additional peripheral components, which can include a keyboard, mouse, and monitor, as well as other devices.

For your monitor, ensure that:

- The monitor accepts universal 100-240 volts AC (VAC), 50/60 Hertz (Hz) power.
- The VGA cable has a 15-pin D-sub connector if you are connecting it directly to a compute module.
- The power cord for the monitor is long enough to reach the power source.
- The plug type on the power cord is compatible with the external power source at the site.

ztC Endurance systems support the ZEN-PERIPH-KBMS keyboard and mouse. See "[System Specifications](#)" on page 287 for the specifications for this keyboard and mouse.

A 6-ft (1.83-m) USB cable is attached to the keyboard. Another 6-ft (1.83-m) USB cable is attached to the mouse.

# 3

## Chapter 3: Installing and Connecting the ztC Endurance System Hardware

When you receive your ztC Endurance system, unpack it as shown on the flap of your system shipping box. You can then review [ztC Endurance 3xx0, 5xx0, and 7xx0 Systems: Deploying a System](#) (R002C), which is located in the shipping box, for a brief overview of your system.



**Notice:** Make sure you read and understand the important safety information in "Safety Precautions" on page 49 before you begin installing and connecting the system.

### Next Steps

Begin installing the ztC Endurance system as described in "Installing the System in a Cabinet" on page 60.

### Safety Precautions

Before installing the system, take the following important precautions:

- Observe all applicable industry safety standards. See "Safety Notices" on page 50.
- Provide the necessary space and light to safely perform the installation.
- Do not wear conducting objects, such as rings, bracelets, and keys.

See "Warnings, Cautions, Notices, and Notes" on page 50 for information about the types of cautionary notes used in this document.

## Warnings, Cautions, Notices, and Notes

Warnings, cautions, notices, and notes provide special information and have the following meanings:



**Warning:** A warning indicates a hazardous situation that, if not avoided, could result in death or serious injury.



**Avertissement:** Un avertissement indique une situation dangereuse qui, si pas évitée, pourrait entraîner la mort ou des blessures graves.



**Caution:** A caution indicates a hazardous situation that, if not avoided, could result in minor or moderate injury.



**Précaution:** Une mise en garde indique une situation dangereuse qui, si pas évitée, pourrait entraîner des blessures mineures ou modérées.



**Notice:** A notice indicates information that, if not acted on, could result in damage to a system, hardware device, program, or data, but does not present a health or safety hazard.



**Note:** A note provides important information about the operation of a ztC Endurance system or related equipment or software.

## Safety Notices

In addition to the safety notices described here, also see:

- ["Environmental Warnings" on page 55](#)
- ["Safety Precautions When Setting Up and Shipping Equipment" on page 56](#)
- ["Power Cord Warnings and Cautions" on page 56](#)
- ["Electrostatic Discharge \(ESD\) Warnings" on page 59](#)
- ["Rack System Installation" on page 60](#)



**Caution:** Risk of explosion if battery is replaced by an incorrect type. Dispose of used batteries according to the instructions provided with the battery.



**Précaution:** Il y'a risque d'explosion si la batterie est remplacée per une batterie de type incorrect. Mettre au rebut les batteries usagées conformément aux instructions.



**Warning:** The system uses two power cords to provide redundant sources of power. To fully remove power from a system, disconnect both power cords.



**Avertissement:** Le système utilise deux cordons d'alimentation pour fournir des sources d'alimentation redondantes. Pour que le système ne soit plus alimenté, déconnecter les deux cordons d'alimentation.



**Caution:** To prevent a cabinet from tipping over and injuring a person or damaging the system, start installing systems from the bottom of the cabinet upward.



**Précaution:** Pour empêcher une armoire de basculer et blesser une personne ou endommager le système, installer le système sur la partie inférieure de l'armoire vers le haut.



**Warning:** To avoid fire, electric shock, and equipment breakdown, prevent water or foreign objects from getting into the equipment. Do not let water or foreign objects, such as pins or paper clips, enter the equipment.



**Avertissement:** Afin d'empêcher un incendie, un choc électrique et la panne de l'équipement, empêcher l'eau ou les objets étrangers de pénétrer dans l'équipement. Ne pas laisser l'eau ou les objets étrangers, comme des épingles ou des trombones, entrer dans l'équipement.



**Warning:** To prevent fire or current leakage, do not plug the power cord into a nonconforming outlet. Use a power outlet with appropriate voltage and power type, as specified in this guide.



**Avertissement:** Pour empêcher un incendie ou une fuite de courant, ne pas brancher le cordon d'alimentation dans une prise non conforme. Utiliser une prise de courant avec la tension et le type d'alimentation appropriés, comme indiqué dans ce guide.



**Caution:** Do not install the equipment where you may need an extension cord. Use of an extension cord that does not meet the power specifications introduces a risk of overheating that could lead to a fire.



**Précaution:** Ne pas installer l'équipement là où il est nécessaire d'utiliser une rallonge. L'utilisation d'une rallonge non conforme aux spécifications en matière d'alimentation induit un risque de surchauffe, ce qui pourrait causer un incendie.



**Warning:** Disconnect the power cords from the server or power source before you install or relocate the equipment. All voltage is removed only when the power cords are disconnected.



**Avertissement:** Débrancher les cordons d'alimentation du serveur ou de la source d'alimentation avant d'installer ou de déplacer l'équipement. La tension est éliminée uniquement lorsque les cordons d'alimentation sont débranchés.



**Warning:** To reduce the risk that electrical shock could injure a person or damage the system, exercise caution when working in the unit even when only one power cord is connected.



**Avertissement:** Pour réduire le risque qu'un choc électrique puisse blesser une personne ou endommager le système, soyez prudent lorsque vous travaillez dans l'appareil, même lorsqu'un seul cordon d'alimentation est connecté.



**Warning:** Do not disassemble, repair, or alter the server, except as described in this documentation. There are no user-serviceable parts within the chassis. The modules and PSU are all tool-less serviceable. Do not use any tools to access or remove any panels or covers. There is a risk of an electric shock or fire as well as equipment malfunction if you do not observe the instructions in this documentation.



**Avertissement:** Ne pas démonter, réparer, ou altérer le serveur, excepté tel que décrit dans cette documentation. Il n'y a pas de pièces pouvant être réparées par l'utilisateur dans le châssis. Les modules et le bloc d'alimentation peuvent être réparés entièrement sans outil. Ne pas utiliser d'outils pour retirer ou accéder aux panneaux ou aux couvercles. Il y a un risque de choc électrique ou d'incendie, ainsi que de mauvais fonctionnements de l'équipement, si vous ne respectez pas les instructions dans cette documentation.



**Caution:** Do not place any object on top of the server. The object may fall off and cause injuries, damage to hardware, or a fire.



**Précaution:** Ne pas placer d'objet en haut du serveur. L'objet peut chuter et causer des blessures, endommager le matériel, ou causer un incendie.



**Caution:** To reduce the risk of personal injury from hot surfaces, allow the drives and the internal system components to cool before touching them.



**Précaution:** Pour diminuer le risque de blessure au contact de surfaces chaudes, laissez refroidir les lecteurs et les composants internes du système avant de les toucher.



### Warnings:

To reduce the risk of personal injury or damage to the equipment:

1. Observe local occupational health and safety requirements and guidelines for manual material handling.
2. Get help to lift and stabilize the product during installation or removal, especially when the product is not fastened to the rails. This server weighs between 74-102 lb (33.6-46.3 kg).

**Avertissements:**

Pour diminuer le risque de blessure ou de dommage à l'équipement:



1. Respectez les exigences et les directives en matière de santé et de sécurité au travail pour la manutention manuelle du matériel.
2. Faites-vous aider pour lever et stabiliser le produit pendant l'installation ou le retrait, en particulier quand le produit n'est pas fixé aux rails. Le serveur pèse entre 33,6 et 46,3 kg (74 à 102 lb). Ce poids indique qu'il faut au minimum trois personnes pour lever le système pendant le déballage, le déplacement et l'installation du système dans un bâti.



**Caution:** Observe caution when inserting compute, storage, or I/O modules. These are moving parts. Keep fingers clear to avoid any possible pinching when pushing the modules into a latched position.



**Précaution:** Soyez prudent lorsque vous insérez une unité centrale de traitement, de la mémoire ou des modules E/S. Ces pièces sont mobiles. Garder les doigts à l'écart pour éviter un pincement au moment de verrouiller les modules en place.



**Notice:** Do not install or store the equipment in an unsuitable place. Install or store the equipment in a place that meets the requirements specified in this guide.

## Environmental Warnings

### Cautions:



1. Do not use or store this product in a corrosive environment.
2. Avoid using or storing this product in an environment that may contain corrosive gases. Such gases include, but are not limited to, sulfur dioxide, hydrogen sulfide, nitrogen dioxide, chlorine, ammonia, or ozone.
3. Avoid installing this product in a dusty environment or one that may contain corrosive materials such as sodium chloride or sulfur.
4. Avoid installing this product in an environment having excessive metal flakes or conductive particles in the air. Such environments may cause corrosion or short circuits within this product, resulting in not only damage to this product, but also fire.
5. If there are any concerns regarding the environment at the planned site of installation or storage, contact your authorized Penguin Solutions service representative.

### Précautions:



1. Ne pas utiliser ou entreposer ce produit dans un milieu corrosif.
2. Éviter d'utiliser ou d'entreposer ce produit dans un environnement qui peut contenir des gaz corrosifs. Ces gaz incluent, mais sans s'y limiter, le dioxyde de soufre, le sulfure d'hydrogène, le dioxyde d'azote, le chlore, l'ammoniac ou l'ozone.
3. Éviter d'installer ce produit dans un environnement poussiéreux ou dans un environnement qui contient des matières corrosives comme le chlorure de sodium ou le soufre.
4. Éviter d'installer ce produit dans un environnement qui contient des écailles de métal ou des particules conductrices dans l'air. Ce type d'environnement peut causer de la corrosion ou des courts-circuits dans le produit, ce qui endommagerait le produit, mais causerait également un incendie.
5. Si vous avez des inquiétudes concernant l'environnement du site où il est prévu d'installer ou entreposer le produit, contactez votre représentant de service Penguin Solutions autorisé.

## **Safety Precautions When Setting Up and Shipping Equipment**

For your protection, observe the following safety precautions when setting up and shipping your equipment:

- Follow all cautions and instructions marked on the equipment.
- Ensure that the voltage and frequency of your power source match the voltage and frequency written on the equipment's electrical rating label.
- Never push objects of any kind through openings in the equipment. Dangerous voltages, energy, or moving parts may be present. Conductive external objects could produce a short circuit that could cause fire, electric shock, or damage to your equipment.
- Do not block or cover the openings of your product. Never place a product near a radiator or heat register. Failure to follow these guidelines can cause overheating and affect the reliability of your product.
- Do not drop the product or subject it to physical shock.
- Keep the product away from water or any liquid.
- To ship the product, pack it inside the qualified package and ship with a pallet.

## **Power Cord Warnings and Cautions**

Installation of this equipment must comply with local and regional electrical regulations governing the installation of information technology equipment by licensed electricians. For electrical power ratings on options, refer to the power rating label or the user documentation supplied with that option.

**Warnings:**

1. When installing a system, always connect the power cord first, before adding communications cables.
2. The power cord contains the protective earth connection; it should be connected first and disconnected last, to maintain a grounded chassis.
3. Before attempting to remove a module from the system chassis, power off the module, disconnect communications cables, and then disconnect the power cord. Before attempting to remove a PSU, disconnect the power cord.
4. Never connect a power cord to a module or PSU when it is not located within the system chassis.
5. Do not connect communications cables to an I/O module that is not installed in a grounded system chassis. Disconnect all communications cables to the I/O module before removing the I/O module from the chassis.

**Avertissements:**

1. Lors de l'installation du système, toujours connecter le cordon d'alimentation en premier, avant d'ajouter les câbles de communication.
2. Le cordon d'alimentation inclut le raccordement à la terre, il doit être connecté en premier et déconnecté en dernier afin que le châssis reste relié à la terre.
3. Avant d'essayer de supprimer un module du châssis du système, s'assurer que le module est hors tension et les câbles de communication sont débranchés. Avant d'essayer de retirer un bloc d'alimentation, débrancher le cordon d'alimentation.
4. Ne jamais connecter un cordon d'alimentation à un module ou un bloc d'alimentation quand il n'est pas situé dans le châssis du système.
5. Ne pas connecter les câbles de communication à un module E/S qui n'est pas installé dans le châssis d'un système relié à la terre. Débrancher tous les câbles de communication du module E/S avant de retirer le module E/S du châssis.

**Cautions:**



1. This product is designed to work with multiple types of grounding systems, specifically TN, where neutral is grounded and for both IT and TN-C where grounded neutral is not used. For IT and TN-C, the branch circuit for L1 and L2 must be supplied by a double-pole circuit breaker. Contact your facilities manager or a qualified electrician if you are not sure what type of power is being supplied to the system.
2. Not all power cords have the same current ratings. Do not use the power cord provided with your equipment for any other products or use. Do not use household extension cords with your product.
3. The outlet for the DC power supply should not be far away from the equipment when using.

**Précautions:**



1. Ce produit est conçu pour fonctionner avec plusieurs types de systèmes de mise à la terre, en particulier TN, où le neutre est mis à la terre, et avec les systèmes IT et TN-C où le neutre relié à la terre n'est pas utilisé. Pour les systèmes IT et TN-C, le circuit de dérivation pour L1 et L2 doit être fourni par un disjoncteur à deux pôles. Contactez votre responsable de réseau ou un électricien qualifié si vous n'êtes pas sûr de savoir quel type d'alimentation est fournie au système.
2. Tous les cordons d'alimentation n'ont pas les mêmes courants nominaux. Utiliser uniquement le cordon d'alimentation fourni avec votre équipement. Ne pas utiliser des cordons d'alimentation domestiques avec votre produit. Ne pas utiliser le cordon d'alimentation fourni avec votre équipement avec d'autres produits ou pour une autre utilisation.
3. La prise d'alimentation C.A. ne doit pas être éloignée de l'équipement pendant son utilisation.

## Electrostatic Discharge (ESD) Warnings

### Cautions:



1. In order to maximize overall product quality and eliminate the possibility of damage from electrostatic discharge, observe ESD handling procedures wherever this symbol occurs during the system integration.
2. All employees must attend an ESD training class prior to performing any system or board handling. If you have not been properly trained, contact your immediate supervisor to schedule the training.
3. Use heel straps on both feet and/or wrist straps where applicable to ensure that you are properly grounded. Test the continuity of the straps at a certified ESD station before working with the products.
4. If you remove your heel straps or wrist straps for any reason, you must retest to ensure proper grounding.
5. Ensure the policies regarding ESD controls for all personnel who work in the manufacturing departments are enforced.

### Précautions:



1. Afin de maximiser la qualité générale du produit et d'éliminer la possibilité de dommage dû à une décharge électrostatique, respectez les procédés de manutention ESD quand le symbole suivant apparaît pendant l'intégration du système.
2. Tous les employés doivent suivre un cours de formation ESD avant d'effectuer la manutention du système ou du tableau. Si vous n'avez pas été correctement formé, contactez votre superviseur immédiat pour planifier la formation.
3. Des bandes antistatiques pour talon à chaque pied et/ou des bracelets antistatiques, le cas échéant, doivent être utilisés pour garantir que vous êtes correctement mis à la terre pendant le test de continuité des bandes au poste ESD certifié.
4. Si vous retirez vos bandes antistatiques pour talon ou vos bracelets antistatiques pour une raison particulière, vous devez refaire le test pour garantir la mise à la terre correcte.
5. Assurez-vous que les politiques concernant les contrôles ESD sont appliquées pour tout le personnel qui travaille dans les départements de production.

## Rack System Installation

The installation instructions include rack-mount instructions identical to or similar to the ones listed in ["Cabinet Requirements" on page 45](#). Be sure to carefully read and observe the Cautions listed in that topic.

### Related Topics

- ["General Safety Precautions" on page 101](#)

## Installing the System in a Cabinet

The general steps for installing the ztC Endurance system in a cabinet are as follows:

1. Number the vertical rails
2. Prepare the support rails for installation
3. Attach the support rails and insert the system into the cabinet

However, before installing the system in a cabinet, make sure that:

- You read and understand all safety precautions in ["Safety Precautions" on page 49](#).
- You read and understand all of the installation steps.
- Your cabinet meets the system requirements, and the site has been properly prepared (see ["Cabinet Requirements" on page 45](#)).
- You write down the asset ID, which is located on top of the system chassis (see [Figure 3-1](#)), and store it in a convenient location.



**Caution:** Making note of the asset ID now is critical. After you install the system, the asset ID label may not be visible in the cabinet, and you need to provide the asset ID during the software installation.

Figure 3-1: Location of Asset ID

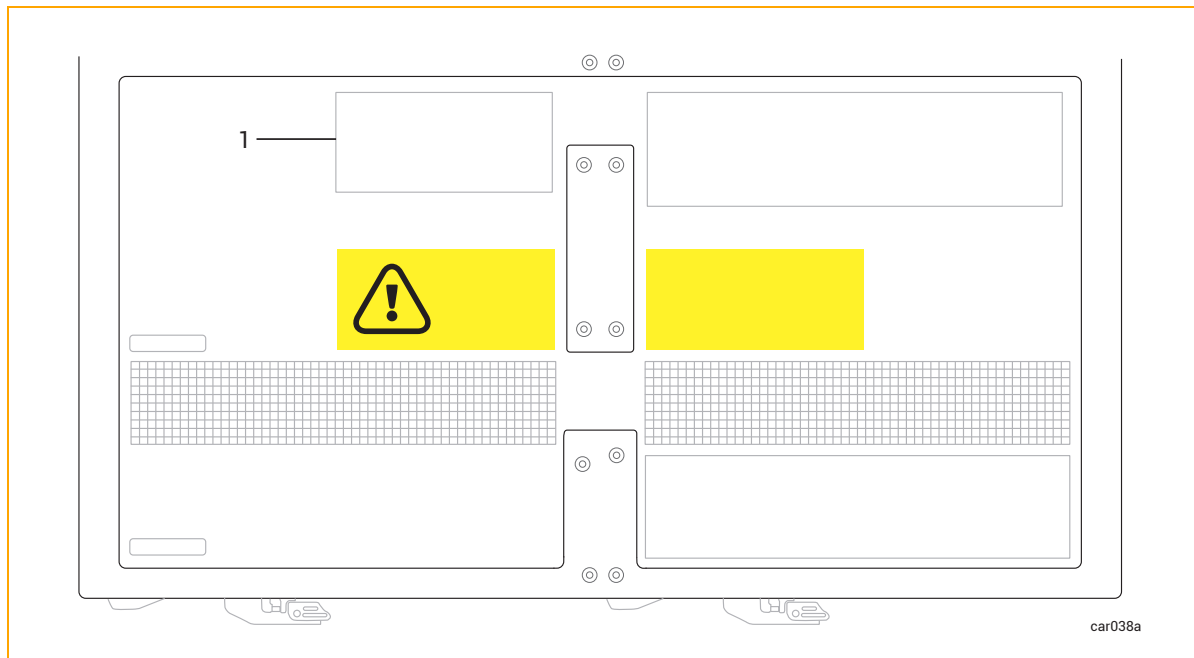

1 Label with asset ID

- You have the components to install:
  - Support rails (2). One is labeled **FRONT LEFT**, and the other is labeled **FRONT RIGHT**. The rails can be extended from 26 3/8 in. (670 mm) to 34 1/4 in. (870 mm).
  - Package labeled **R0897-E0112-01** that contains eight flat-head alignment screws (silver). Use these screws to align the mounting rails to the cabinet during installation.
  - Package labeled **R0897-E0113-01** that contains four Phillips/hex-head screws (black). Use these screws to secure the rail to the rear of the cabinet.
- You have the required tools: a flat-head screwdriver and a #2 Phillips-head screwdriver.



**Caution:** To avoid personal injury or damage to the system, two persons are recommended to insert the system in a cabinet.



**Précaution:** Pour éviter toute blessure corporelle ou tout dommage à l'étagère, deux personnes sont recommandées pour insérer l'étagère dans l'armoire et sur les supports de montage.

## Next Steps

Start installing the system in a cabinet as described in ["Numbering the Vertical Rails"](#) on page 62.

### Numbering the Vertical Rails

When you install a system in a cabinet, you first need to number the vertical rails, if they are not already numbered. To do so, use a marker or pencil to number the holes of the 2U in which to install each system.

The cabinet rails, system, and various components are measured in Electronic Industries Alliance (EIA) rack units (U). Every three holes on the EIA square-hole pattern on the vertical rail equals one U (1.75 in., 4.45 cm). The holes on EIA rails are in a repeating pattern of 1/2 in. (1.27 cm), 5/8 in. (1.59 cm), 5/8 in. (1.59 cm), as shown in [Figure 3-2](#). The middle hole of each U has equal spacing between it and the holes adjacent to it. In some cabinets, numbers on the vertical rails identify the middle hole of each U.

Figure 3-2: EIA Vertical Rail Hole Pattern

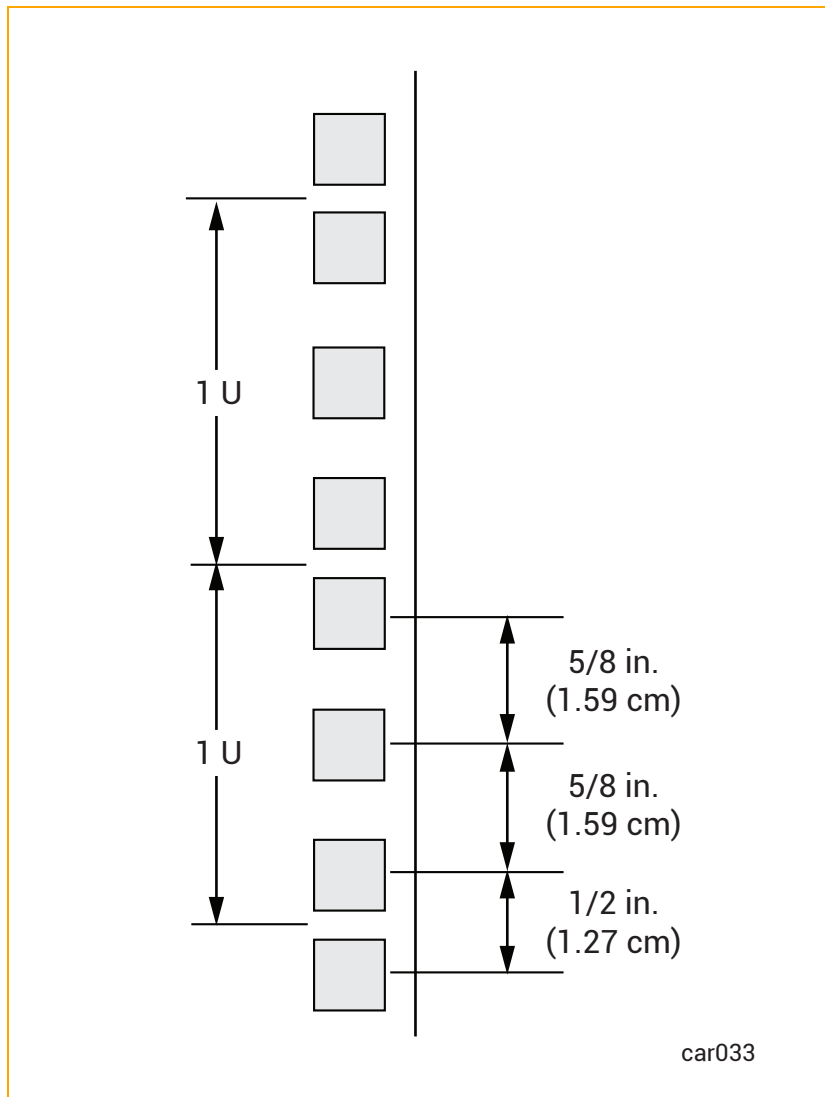

### To number the vertical rails

1. On each of the front and rear vertical rails, number the 2U spaces where you will install the system.



**Notice:** To ensure that the components will be level when you install them, mark the same holes on the rear vertical rails that you marked on the front vertical rails.

2. If you are installing additional systems in the same cabinet, continue numbering another 2U for each system.

## Next Steps

To continue with installing a system in a cabinet, see ["Preparing the Support Rails for Installation" on page 64](#).

## Preparing the Support Rails for Installation

When installing a system in a cabinet, you need to prepare the support rails for installation after you have numbered the vertical rails.

### To prepare the support rails

1. Unpack the components and place them on a stable work surface. Attached to the rails are alignment/support screws for use in cabinet rails with round 13/64 in. (5 mm) holes.
  - If your cabinet rails have round 13/64 in. (5 mm) mounting holes, skip this section and continue to ["Attaching the Support Rails and Inserting the System" on page 67](#).
  - If your cabinet rails have square 3/8 in. (9.525 mm) mounting holes, use the silver alignment screws (located in the package labeled **R0897-E0112-01**) in place of the screws that are already installed. Go to step 2.
2. Positioning a flat-head screwdriver in the middle of the front latch, pry open the latch. See [Figure 3-3](#).

**Figure 3-3: Positioning Screwdriver and Opening Latch**

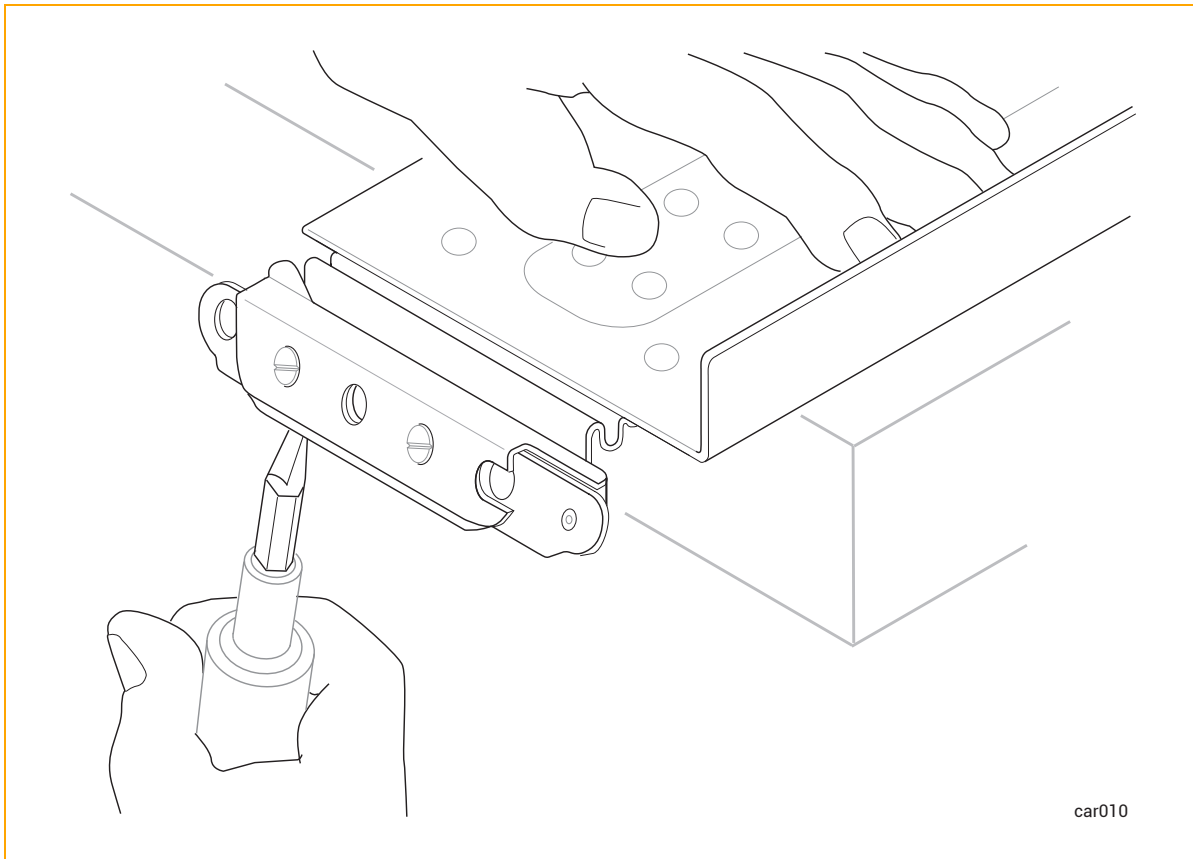

3. While the latch is in the open position, use a flat-head screwdriver to remove the two existing alignment screws. See [Figure 3-4](#).

**Figure 3-4: Removing Existing Alignment Screws**

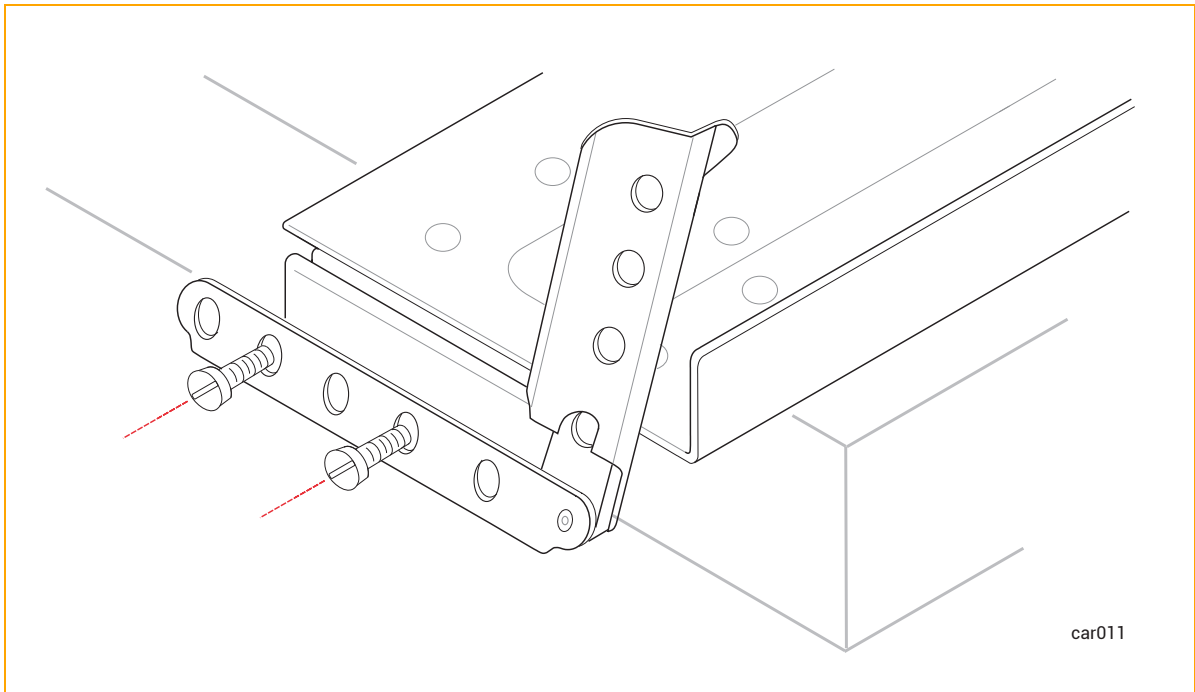

4. Use a flat-head screwdriver to attach two silver alignment screws in the holes that the previous alignment screws were in. Keep the latch open. See [Figure 3-5](#).

**Figure 3-5: Attaching Silver Alignment Screws**

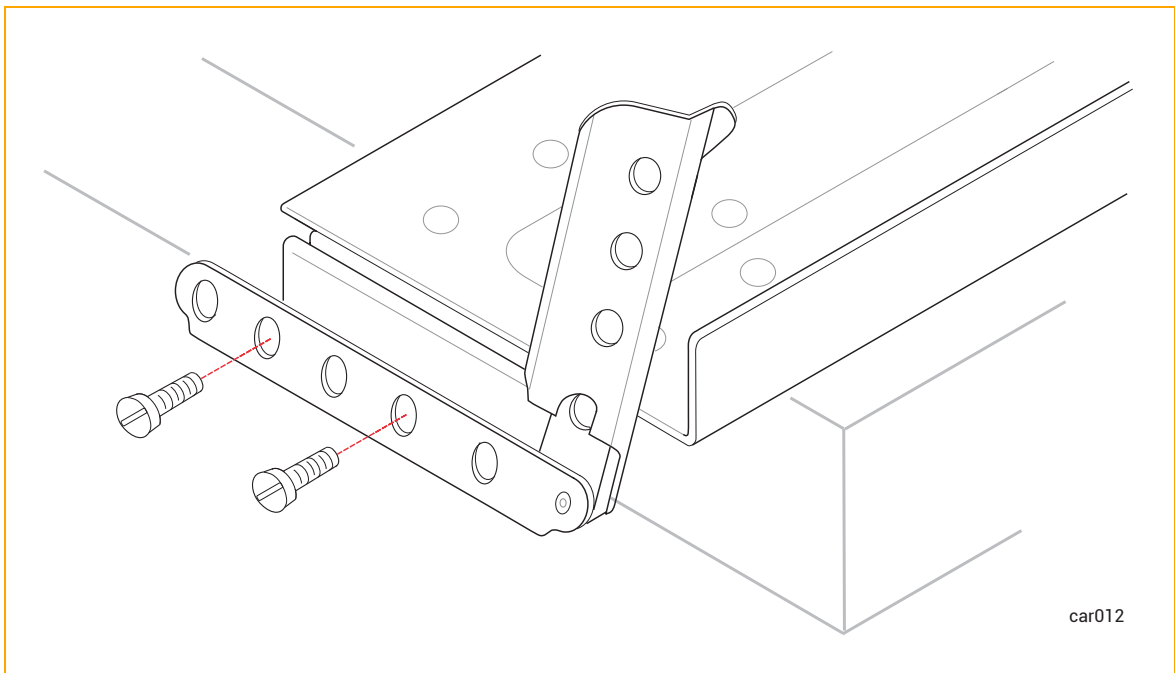

5. Repeat steps 3-4 for the rear latch.
6. Repeat steps 3-5 for the other support rail.

## Next Steps

To continue installing a system in a cabinet, see ["Attaching the Support Rails and Inserting the System" on page 67](#).

## Attaching the Support Rails and Inserting the System

After you have prepared the support rails for installation, attach the support rails to the vertical rails in the cabinet, and then insert the system into the cabinet.

### To attach the support rails

1. Hold the support rail labeled **FRONT LEFT** and face the front of the cabinet.
2. Align the silver alignment screws in the front of the left support rail with the 2U holes that you marked in ["Numbering the Vertical Rails" on page 62](#) (that is, the third hole of the first U and the second hole of the second U). Close the latch. See [Figure 3-6](#).

**Figure 3-6: Securing Front of Support Rail**

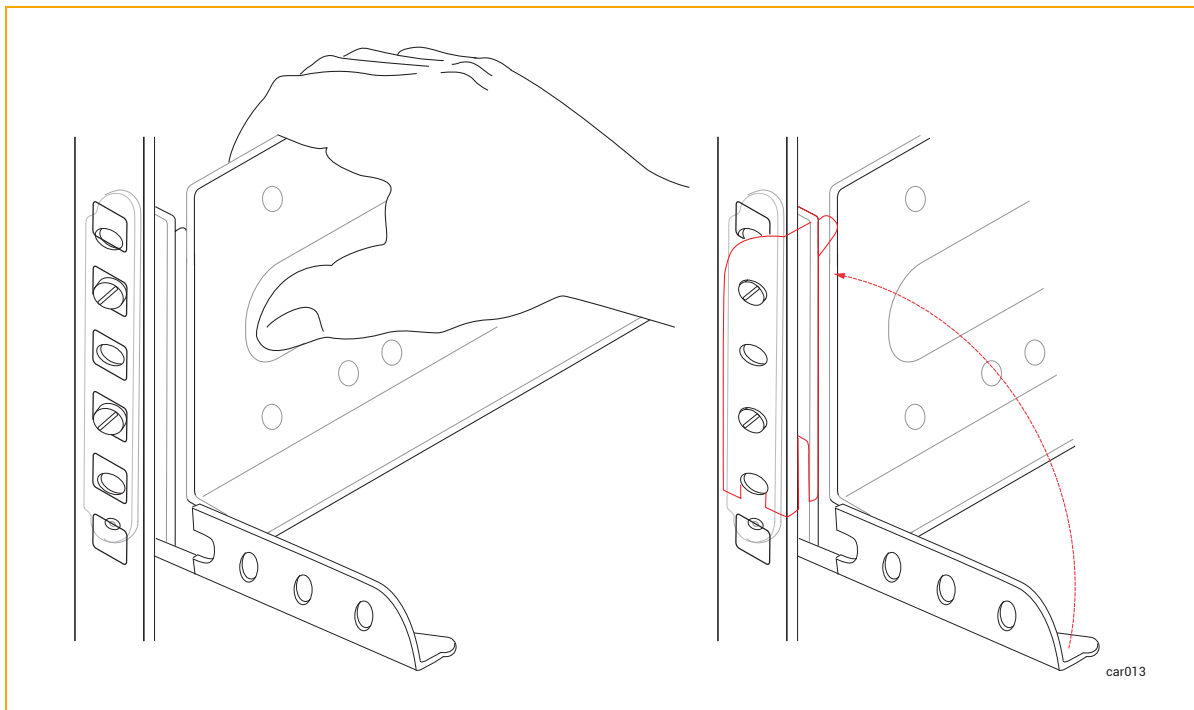

3. Moving to the rear of the cabinet, align the silver alignment screws in the rear of the left support rail with the 2U holes that you marked in ["Numbering the Vertical Rails" on page 62](#). Adjust the

support rail as necessary to fit the depth of the cabinet and close the latch.

4. Secure the rear of the rail by using a Phillips-head screwdriver to attach two black Phillips-head/hex screws in the holes below the silver alignment screws. See [Figure 3-7](#).

**Figure 3-7: Securing Rear Support Rail**

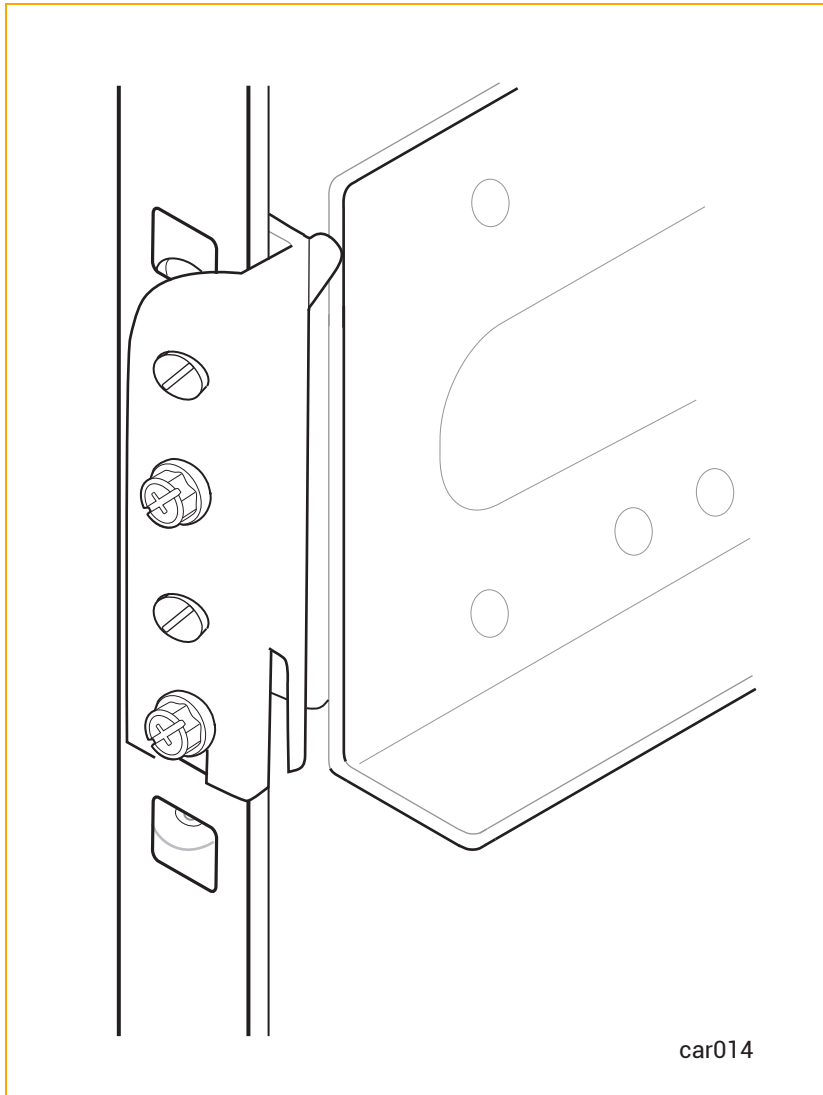

Perform steps 1-4 for the right support rail.

### To insert the system in a cabinet



**Notice:** [Remove the compute modules](#) before you install the system in a cabinet. Doing so reduces the overall weight of the system, making the system easier to lift and install.



**Caution:** To avoid personal injury or damage to the system, up to three persons may be needed to insert the system in a cabinet.



**Précaution:** Pour éviter toute blessure corporelle ou tout dommage à l'étagère, au moins trois personnes sont fortement recommandées pour insérer l'étagère dans l'armoire et sur les supports de montage.

1. With one person on each side of the system and (ideally) one person in the front of the system, align it in the front cabinet opening and place it on the mounting rails.
2. Slide the system into the cabinet until the left and right ears are flush with the cabinet rails. See [Figure 3-8](#).

**Figure 3-8: Inserting System into Cabinet**

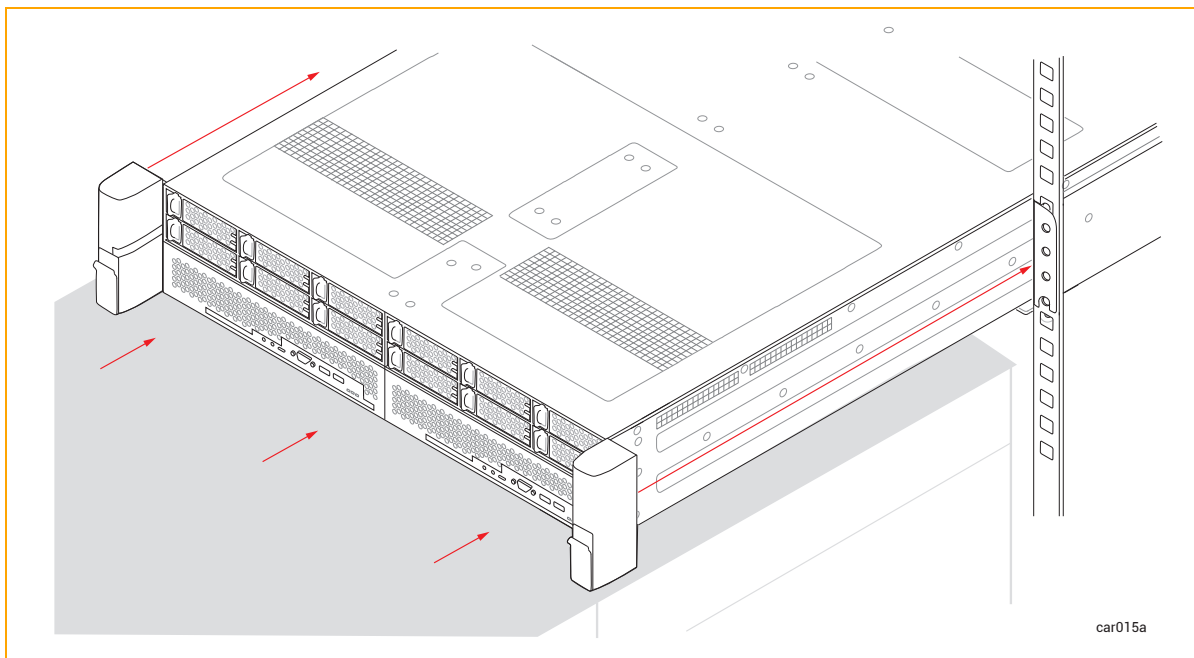

3. On the right ear, pull down the latch and use the Phillips-head screwdriver to secure the captive screw to the rail. Securing this captive screw fastens the system chassis and the front rail to the vertical rail of the cabinet. See [Figure 3-9](#).

**Figure 3-9: Attaching Captive Screws**

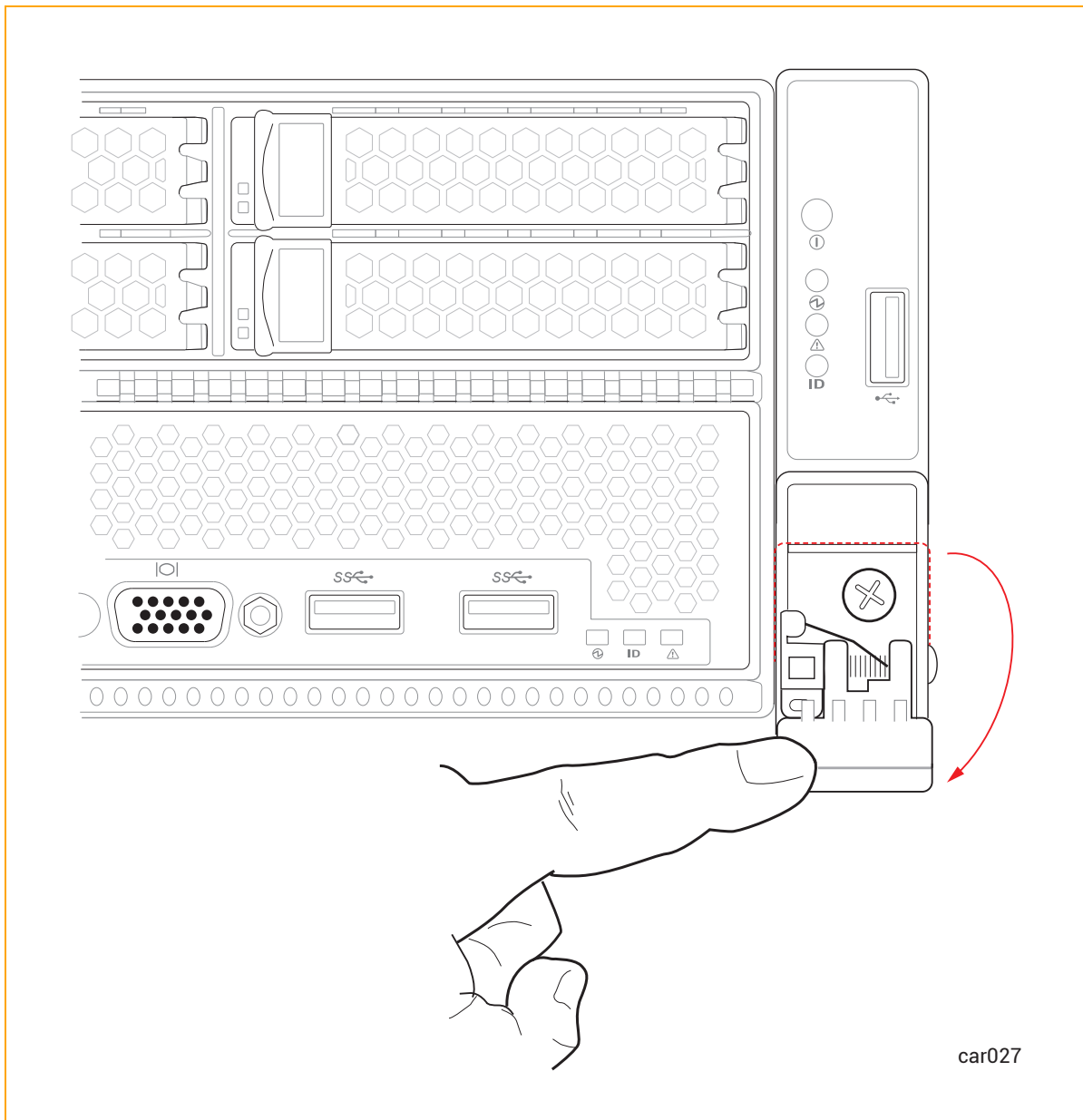

4. Repeat step 3 for the left ear.

### **Next Steps**

Complete the hardware set-up, as described in ["Completing the Hardware Set-up" on page 70](#).

### **Completing the Hardware Set-up**

After you install the ztC Endurance system hardware, complete the system hardware set-up:

["I. Connect Network Cables" on page 71](#)

"II. Connect a Mouse, Keyboard, and Monitor" on page 71

"III. Connect the System to Electrical Power" on page 73

"IV. Insert Blank Disks into Storage Modules" on page 78

No tools are required for these tasks.



**Note:** When routing cables within the cabinet, keep all power cords as separate as possible from peripheral and communication cables. For example, route all power cords on one side of the cabinet and all peripheral and communications cables on the other side of the cabinet, using the cable-management rings on your cabinet to constrain the cords and cables.

### I. Connect Network Cables

In both I/O modules, connect network cables from the bottom two **10G PORT2** ports to a production network and from the **1G MGMT** port to a management network. [Figure 3-10](#) shows the location of the network ports on the rear of the system.

**Figure 3-10: Location of Network Ports**

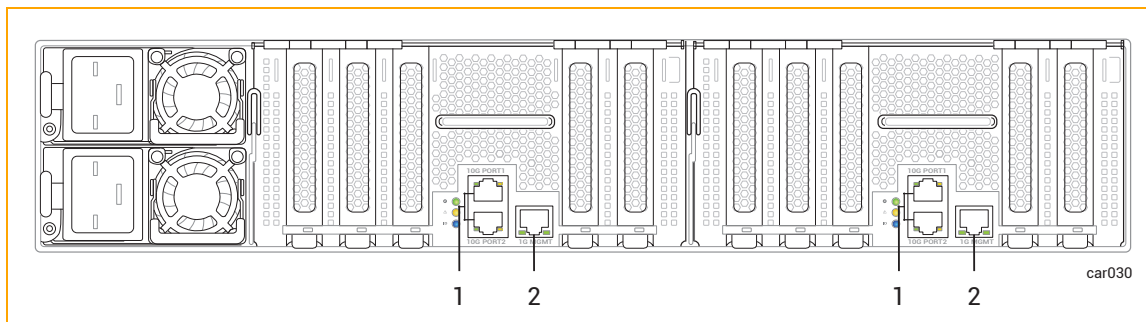

1	10G ports (4)
2	1G MGMT ports (2)

### II. Connect a Mouse, Keyboard, and Monitor

To prepare for the software installation, connect two monitors (user-supplied) and two keyboards and mice (supplied by Penguin Solutions, if ordered) to ports on the system.

**Notes:**



1. Because the installation requires you to respond to prompts on both compute modules, connecting two monitors and keyboards means that you can view the activities on both compute modules simultaneously. If you can connect only one monitor and keyboard, you need to open a separate KVM console for each compute module.
2. Other keyboards and mice have not been tested and may not work properly.

For information about monitor and keyboard requirements, see "Site Planning for Peripheral Components" on page 48.

**To connect a mouse, keyboard, and VGA monitor**

1. Connect the USB cables from the mouse and keyboard to USB ports on a compute module (see Figure 3-11).



**Notice:** Do not connect the mouse or keyboard to the USB 2.0 port on the control-panel ear.

**Figure 3-11: Location of VGA and USB Ports**

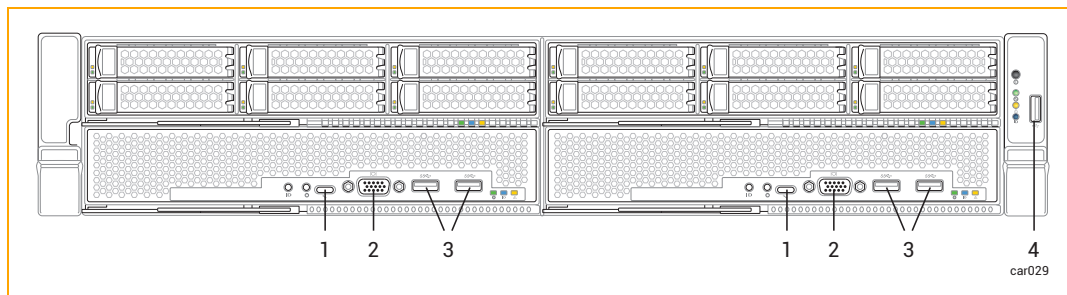

1	Debug ports (2)	3	USB 3.0 ports (4)
2	VGA (monitor port) (2)	4	USB 2.0 port (1)

2. Connect the 15-pin D-sub connector on the VGA cable from the monitor to the system's VGA port on a compute module (see Figure 3-11).
3. Connect the VGA cable to the monitor.

### III. Connect the System to Electrical Power

For both power supply units (PSUs), connect power cords from the power inlets to supported power sources, and then fasten the power-cord retention strap. This strap helps prevent unintentionally disconnecting the power cord from the system if the system is removed from the cabinet.

For information about electrical power planning, see ["Electrical Power Planning" on page 38](#).

#### Warnings:



1. A ztC Endurance 31x0 or 51x0 system can operate in either the low-voltage or high-voltage range (see ["System Specifications" on page 287](#) for details). Make sure you are using power cords that have the correct voltage range and that are rated for your country (see ["Power Cords" on page 40](#)). If you are changing to a different voltage range, follow the instructions described in [To replace both power cords](#).
2. Both PSUs in a ztC Endurance system must operate in the same voltage range.

#### Avertissements:



1. Le système ztC Endurance 31x0 ou 51x0 peut fonctionner en basse ou haute tension (voir ["System Specifications" on page 287](#) pour plus de détails). Assurez-vous que vous utilisez des cordons d'alimentation dont la plage de tension est correcte et qui sont adaptés à votre pays (voir ["Power Cords" on page 40](#)). Si vous passez à une plage de tension différente, suivez les instructions décrites dans la section [Pour remplacer les deux cordons d'alimentation](#).
2. Les deux blocs d'alimentation d'un système ztC Endurance doivent fonctionner dans la même plage de tension.

#### To connect the system to AC power mains

1. From the front and back of the system, make sure that all modules and PSUs are fully inserted.
2. Locate the two power cords for the system.

3. Connect the female end of the A-side power cord to the top PSU, as shown in [Figure 3-12](#). Connect the other end to the A-side power source.
4. Connect the female end of the B-side power cord to the bottom PSU, as shown in [Figure 3-12](#). Connect the other end to a second, separate, B-side power source.

**Figure 3-12: Connecting a System Directly to AC Power**

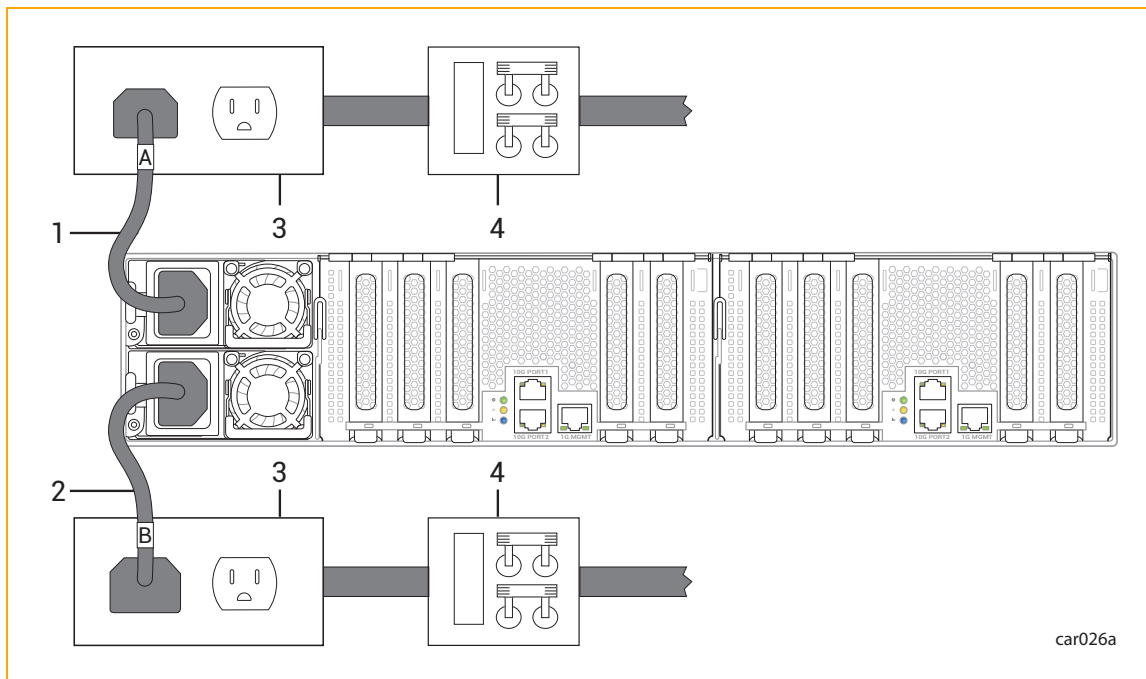

1	A-side power cord	3	AC power outlets
2	B-side power cord	4	AC power (mains) distribution circuit breakers (maximum of 20A)

#### To fasten the power-cord retention strap

1. Locate the power-cord retention strap on PSU A, the upper PSU at the rear of the system, as shown in [Figure 3-13](#).

Figure 3-13: Locating the Power-Cord Retention Strap

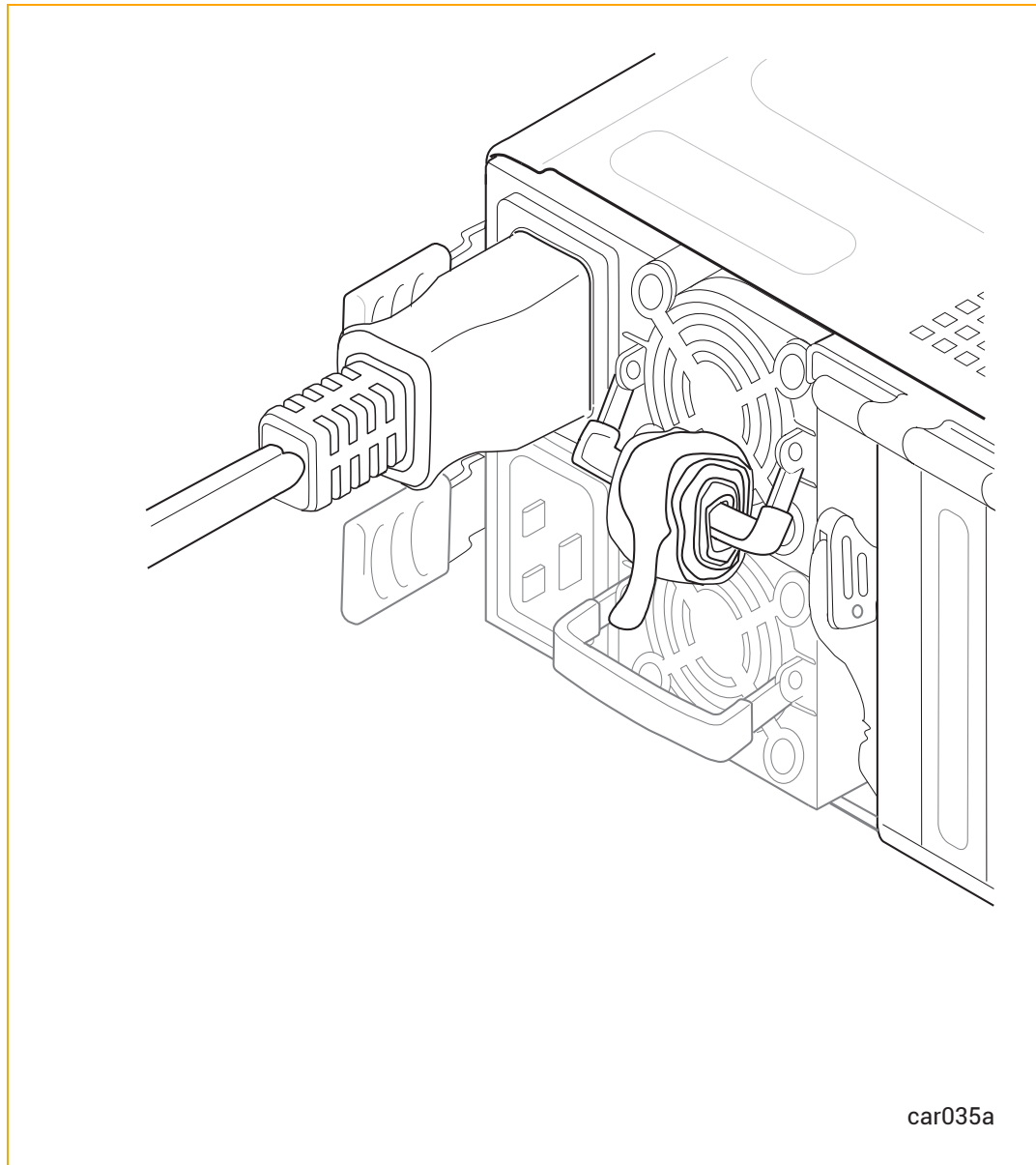

2. Pull on the end of the coiled strap to extend it, as shown in [Figure 3-14](#).

**Figure 3-14: Extending the Power-Cord Retention Strap**

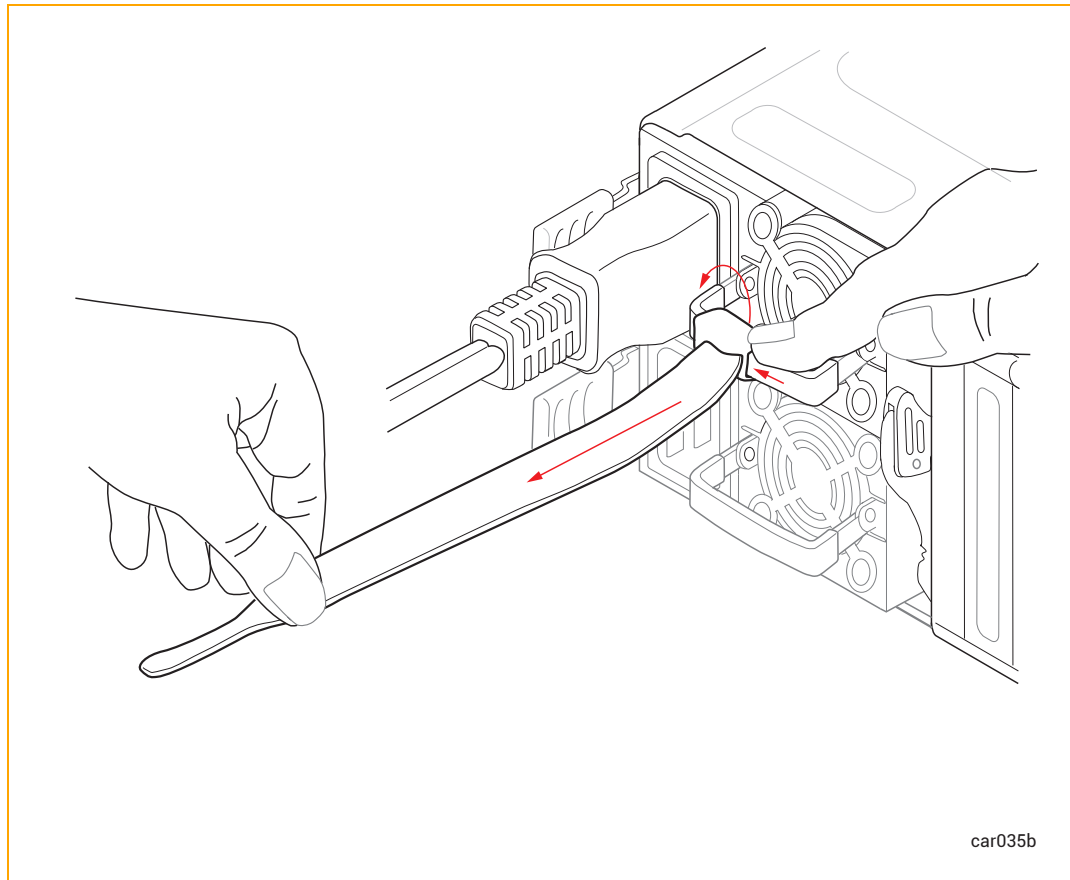

3. Wrap the strap tightly against the molded rib of the power cord to prevent the power cord from moving, as shown in [Figure 3-15](#).

Figure 3-15: Installing the Power-Cord Retention Strap

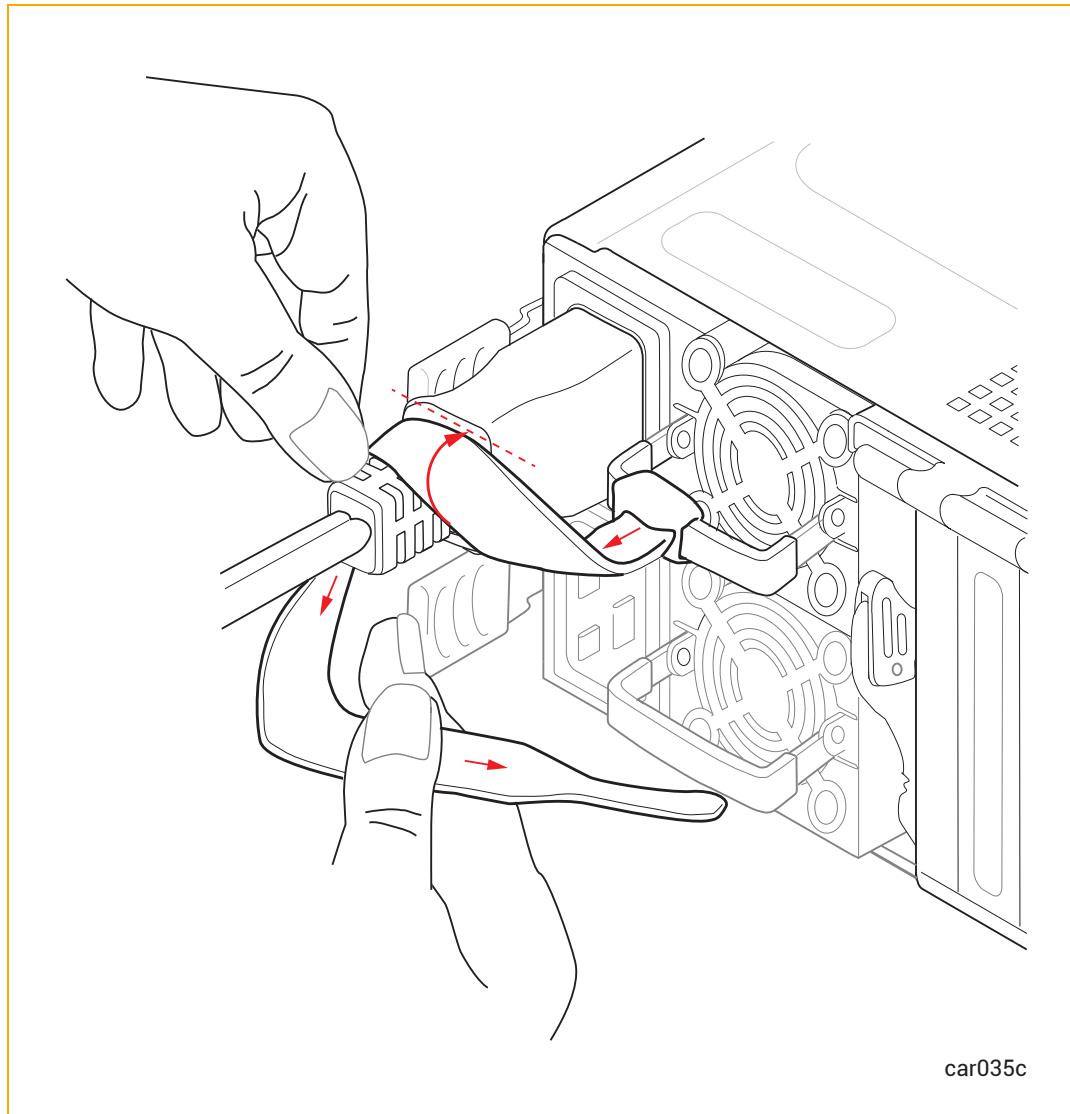

4. Continue wrapping the strap around the power cord until the strap is tightly in place, as shown in [Figure 3-16](#).

**Figure 3-16: Correct Installation of the Power-Cord Retention Strap**

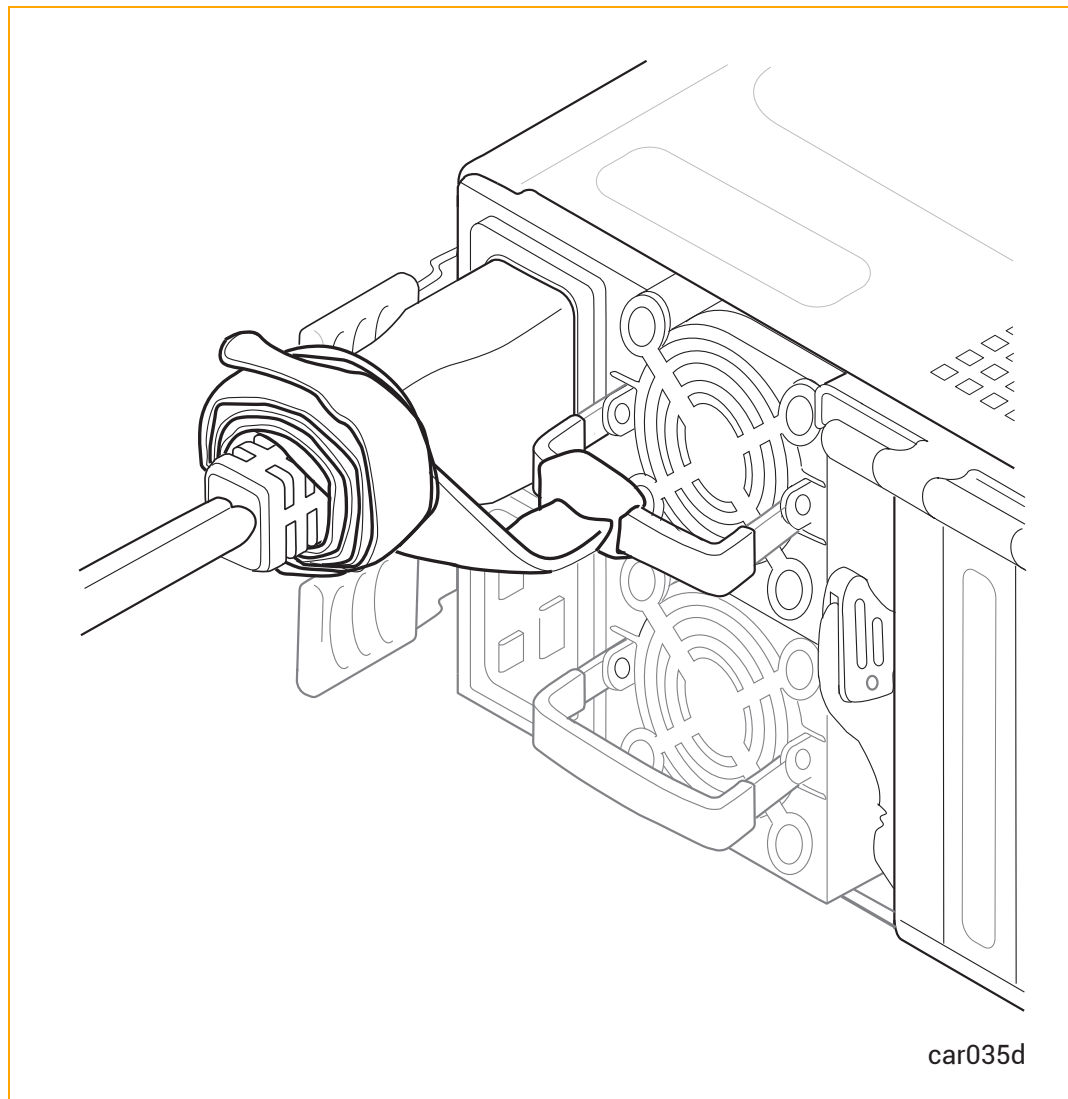

5. Repeat this procedure on PSU B, the lower PSU.

#### **IV. Insert Blank Disks into Storage Modules**

Insert a blank disk into the top-left slot of each storage module to install as system disks. (See "[Disk Drives](#)" on page 27 if you need additional information.) These disks should have the same model, firmware level, and geometry.



**Notice:** At this time, do not install any disks that contain data in order to prevent possible problems.

## Next Steps

Install the system software, as described in ["Installing the System Software" on page 147](#).



# 4

## Chapter 4: Operating the ztC Endurance System Hardware

To learn more about operating and troubleshooting the ztC Endurance hardware, see:

- ["Hardware Operation" on page 81](#)
- ["Troubleshooting the Hardware" on page 85](#)

### Hardware Operation

To learn more about operating the ztC Endurance hardware, see:

- ["Standby Power" on page 81](#)
- ["System Power" on page 82](#)
- ["Fan Speed" on page 85](#)

### Related Topics

- ["Troubleshooting the Hardware" on page 85](#)

### Standby Power

When one or both of the PSU power cords are connected to live power outlets, low-level standby power is present in the system. Standby power enables the primary Baseboard Management Controller (BMC) to monitor the status of system components, even when the system power is off.



**Note:** When you apply external power to the system, the BMC takes approximately 2 minutes to initialize. During this time, standby power, status LEDs, and the remote BMC cannot operate. The system power button may be able to operate before the BMC is fully initialized.

Standby power also allows for continuous operation of the ports used for the BMC: the 1G management ports (see "[System Ports](#)" on page 19). Therefore, while the system power is off, administrators (or, if authorized, Penguin Solutions Customer Service) can still connect to the system through the 1G management ports to diagnose problems, or to turn system power on and off from a remote location.



**Warning:** Standby power remains present even after the system has been powered down. To remove power to the standby devices, remove the power cords.



**Avertissement:** Une alimentation de réserve reste présente même après l'extinction du système. Pour couper l'alimentation des appareils de réserve, enlever les cordons d'alimentation.

### Related Topics

- "[System Power](#)" on page 82
- "[System Ports](#)" on page 19
- "[PSUs](#)" on page 33

### System Power

ztC Endurance systems have one power button located on the control-panel ear. Press this button to start the system.

### Pressing the Power Button

The system power button functions as follows, assuming both compute modules are in the same state:



**Note:** The power button affects both compute modules. Therefore, if one compute module is powered off and one is booted, pressing the power button results in one compute module turning on and the other shutting down.

- If the system power is off and standby power is on, pressing the power button turns the system on and boots the operating system. See "[Starting Up the System](#)" on page 82.
- If the operating system hangs or a hardware failure occurs, pressing the power button for several seconds (a "long press") initiates a forced system shutdown (though standby power remains on).

### Starting Up the System

Make sure the system power cords are plugged into a live power source.

## To boot a system and start the operating system

1. Turn on the monitor.
2. Press the power button on the control-panel ear. See [Figure 4-1](#).

**Figure 4-1: Power Button**

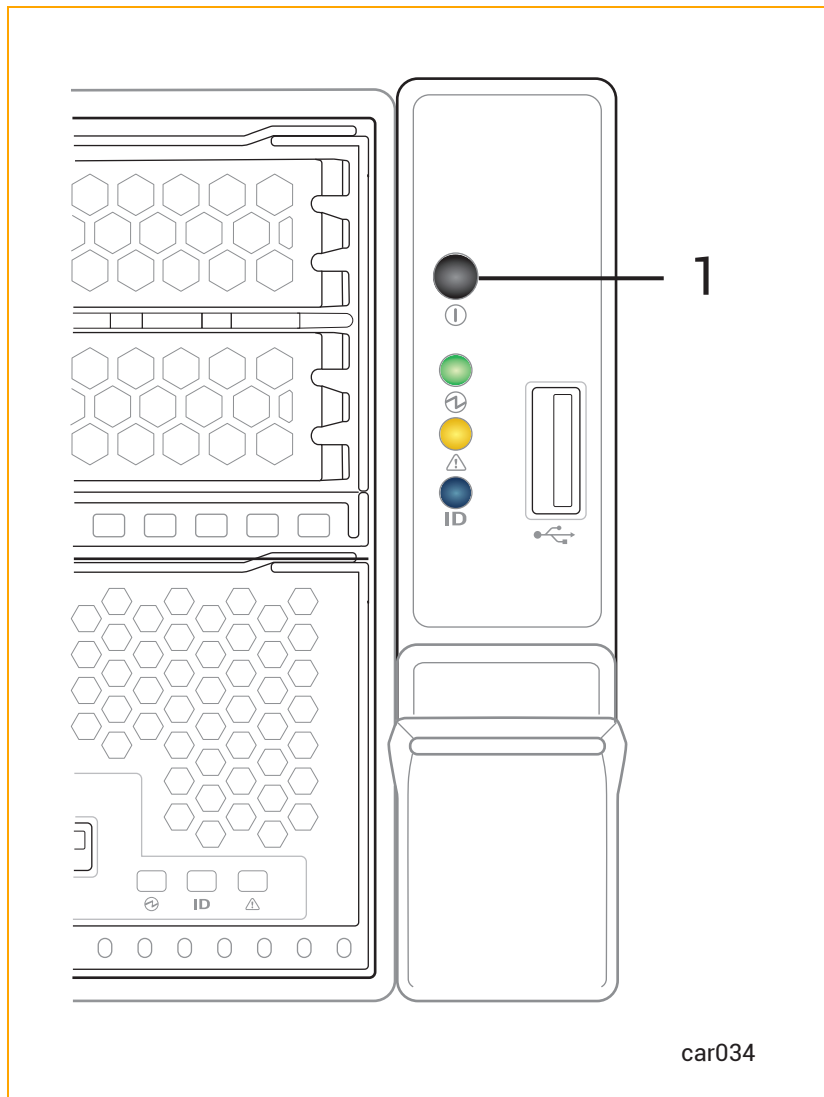

1 Power button

## Shutting Down the System



**Warning:** The system's standby devices have power even after the system has been powered down. To remove power to the standby devices, you must remove the power cords.



**Avertissement:** Les appareils de réserve du système restent alimentés même après l'extinction du système. Pour couper l'alimentation des appareils de réserve, vous devez enlever les cordons d'alimentation.

Exit from all applications before shutting down a system.

### To shut down a Windows-based system



**Notice:** To properly shut down the system, use only methods provided by ztC Endurance and Automated Uptime Layer with Smart Exchange; only these methods will properly shut down both the active compute module and the standby compute module that monitors system health for continuous uptime.

If you attempt to shut down the system by using standard Windows shut down methods, the standby compute module will remain running. When the standby OS detects that the active compute module is down, the standby module automatically takes ownership of the system devices, assumes the role of the active compute module, and restarts the Windows host, which prevents the shutdown.

To shut down a Windows-based system gracefully, click **Shutdown** on the **Dashboard** page of the ztC Endurance console.



**Notice:** Do not use the BMC Web console to power off a running ztC Endurance system. See "[Unsupported BMC Web Console Features](#)" on page 275 for more information.

When you shut down a Windows-based system, note that the following behavior is normal:

- The system stays powered on for several minutes, as all services are stopped and cached data is written to disk.
- The Ethernet activity and connection-speed LEDs for embedded Ethernet ports may remain lit even when the system is powered down, if Wake On LAN is enabled in the system BIOS.



**Note:** Wake On LAN is supported only for the host's or BMC's connection to the 1G management network.

## Enabling and Disabling Wake on LAN

The Wake On LAN (WOL) networking standard allows a computer to be turned on or awakened from sleep mode remotely via a network message.

The following instructions allow you to enable or disable WOL for ports on your ztC Endurance system.



**Notice:** Do not change any other BIOS settings unless Penguin Solutions Customer Service has advised you to do so.

### To enable WOL

1. As the system starts to boot, press either the **Delete** key or the **Esc** key until the system BIOS setup utility appears.
2. When the utility screen appears, use the arrow keys to go to the Advanced menu.
3. Select Intel(R) i210 Gigabit Backplane Connection and press **Enter**.
4. Select NIC Configuration and then select the port that you want to enable. Press **Enter**.
5. Use the +/- keys to change Wake On LAN to Enabled and press **Enter**.
6. Press **F4** to save your changes and exit the utility.

### To disable WOL

1. Download the Intel® Ethernet Flash Firmware Utility (BootUtil) from the following Web site:  
<https://www.intel.com/content/www/us/en/support/articles/000005790/software/manageability-products.html>
2. Use the -WOLDISABLE or -WOLD option of BootUtil to disable WOL functionality on the selected port, as described in the preceding Web site.

## Fan Speed

You might notice fan-speed increases in high-temperature environments, during high system activity periods, while loading the operating system software, shutting down the system, or restarting the operating system. The increase in fan speed ensures adequate cooling under these conditions and is normal behavior.

### Related Topics

- ["Troubleshooting the Hardware" on page 85](#)

## Troubleshooting the Hardware

To learn more about troubleshooting the ztC Endurance hardware, see:

- "Status LEDs" on page 86
- "Internal Disk Drive Problems and Solutions" on page 95
- "Using the NMI Button" on page 96

**Related Topics**

- "Hardware Operation" on page 81

**Status LEDs**

Status LEDs are located on the control-panel ear as well as the front of each CRU module. This topic illustrates and describes these LEDs. See [Figure 4-2](#) and [Figure 4-3](#), as well as [Table 4-1](#), [Table 4-2](#), [Table 4-3](#), [Table 4-4](#), and [Table 4-5](#).

You can use the ATTN LEDs to diagnose faults, as described in "Using the ATTN LEDs to Diagnose Faults" on page 94.

**Figure 4-2: Front LEDs: Storage Module, Control-panel Ear, and Compute Module**

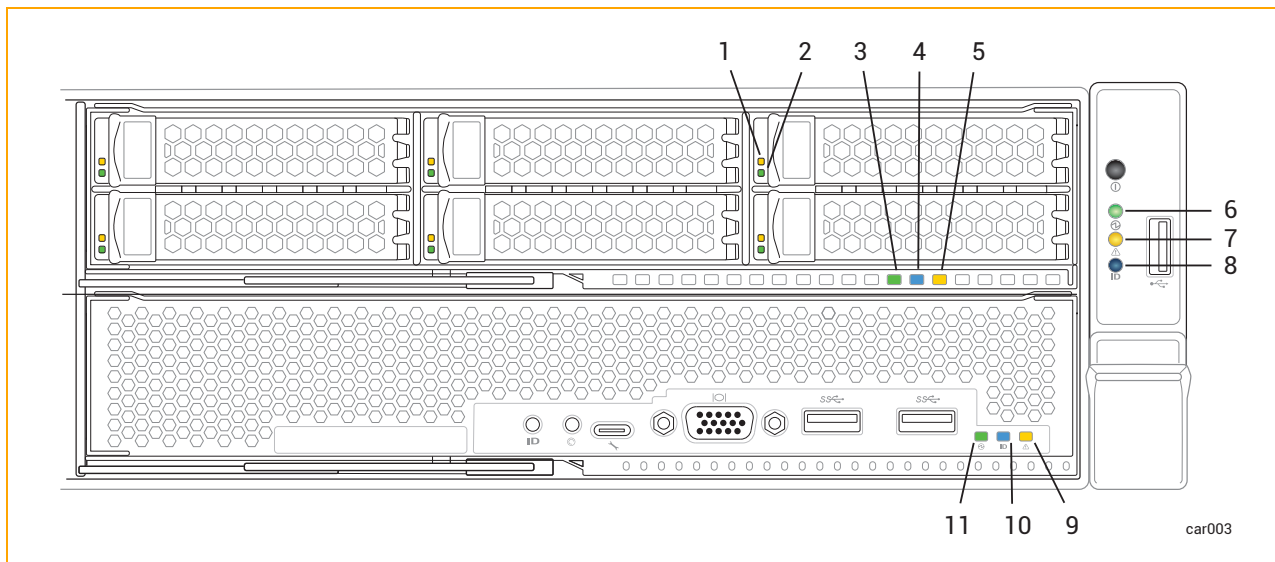

**Table 4-1: Front LEDs: Storage Module**

Callout	LED	State	Description
1	Fault	Off	Normal operation.
		Solid amber	The disk is broken and safe to remove. See <a href="#">"Removing and Inserting a Disk Drive"</a> on page 114.

Table 4-1: Front LEDs: Storage Module

Callout	LED	State	Description
2	ACT	Off	For 6.4 TB disks, indicates that the disk is present but idle.
		Solid green	For 1.6 TB or 3.2 TB disks, indicates that the disk is present but idle.
		Blinking green	Data is being written to or read from the disk.
3	PWR	Off	DC power and standby power to the module are off.
		Solid green	DC power to the module is on.
		Blinking green	Standby power to the system is on; DC power to the module is off.
4	UID	Off	No request to identify module activated (normal operation).  To identify, see <a href="#">"Identifying a System or Component" on page 250</a> .
		Solid blue	Request to identify module activated; LED illuminates with DC power or with standby power.
5	ATTN	Off	Indicates one of two scenarios: <ul style="list-style-type: none"> <li>• The module does not need to be replaced.</li> <li>• The module needs to be replaced, but the module is not safe to remove.</li> </ul> <p>To determine which scenario is true, check the control-panel ear's ATTN LED. If that LED is not illuminated, no module in the system needs to be replaced.</p>
		Blinking amber	Fault; safe to replace the module. LED illuminates with DC power or with standby

**Table 4-1: Front LEDs: Storage Module**

Callout	LED	State	Description
			power. To replace, see <a href="#">"Removing and Replacing a Storage Module"</a> on page 112.

**Table 4-2: Front LEDs: Control-Panel Ear**

Callout	LED	State	Description
6	PWR	Off	DC power and standby power to the module are off. To turn power on or off, press the power button on the control-panel ear or use the BMC. See <a href="#">"System Power"</a> on page 82.
		Solid green	DC power to any module is on.
		Blinking green	Standby power is on; no module has DC power.
7	ATTN	Off	Indicates one of two scenarios: <ul style="list-style-type: none"> <li>Standby power is off.</li> <li>Standby power is on, but no compute module is inserted.</li> </ul>
		Solid green	Indicates one of two scenarios: <ul style="list-style-type: none"> <li>Standby power is on, at least one compute module is inserted, but the Stratus Management Service is not running.</li> <li>None of the three scenarios that cause the LED to blink amber has occurred.</li> </ul>
		Blinking amber	Indicates one of three scenarios: <ul style="list-style-type: none"> <li>The Windows OS is booted, the Stratus Management Service is</li> </ul>

Table 4-2: Front LEDs: Control-Panel Ear

Callout	LED	State	Description
			<p>running, and one or more modules are not inserted or need replacement.</p> <ul style="list-style-type: none"> <li>• One member of a teamed PCIe adapter or Fibre Channel cable has been removed.</li> <li>• A disk drive is missing from a mirrored pair, either because of physical removal or because it needs replacement.</li> </ul> <p>Check LEDs of all modules to identify the module with a fault. For a list of modules, see <a href="#">"System CRU Modules"</a> on page 20.</p> <div style="border: 1px solid #00AEEF; padding: 10px; margin-top: 10px;"> <p><b>Note:</b> After a total system shutdown, the ATTN LED remains in the last state it was in until you remove and restore standby power.</p> </div>
8	UID	Off	<p>No request to identify module activated (normal operation).</p> <p>To identify, see <a href="#">"Identifying a System or Component"</a> on page 250.</p>
		Solid blue	<p>Request to identify module activated; LED illuminates with DC power or with standby power.</p>

Table 4-3: Front LEDs: Compute Module

Callout	LED	State	Description
9	ATTN	Off	<p>Indicates one of two scenarios:</p> <ul style="list-style-type: none"> <li>• The module does not need to be replaced.</li> </ul>

**Table 4-3: Front LEDs: Compute Module**

Callout	LED	State	Description
			<ul style="list-style-type: none"> <li>The module needs to be replaced, but the module is not safe to remove.</li> </ul> <p>To determine which scenario is true, check the control-panel ear's ATTN LED. If that LED is not illuminated, no module in the system needs to be replaced.</p>
		Blinking amber	<p>Fault; safe to replace the module. LED illuminates with DC power or with standby power.</p> <p>See <a href="#">"Removing and Replacing a Compute Module" on page 103</a>.</p>
10	UID	Off	<p>No request to identify module activated (normal operation).</p> <p>To identify, see <a href="#">"Identifying a System or Component" on page 250</a>.</p>
		Solid blue	<p>Request to identify module activated; LED illuminates with DC power or with standby power.</p>
11	PWR	Off	<p>The module's DC power is off, and the other compute module's DC power is on.</p>
		Solid green	<p>The module has DC power (standby power is also on).</p>
		Blinking green	<p>The system has standby power only.</p>

Figure 4-3: Rear LEDs: PSUs and I/O Module

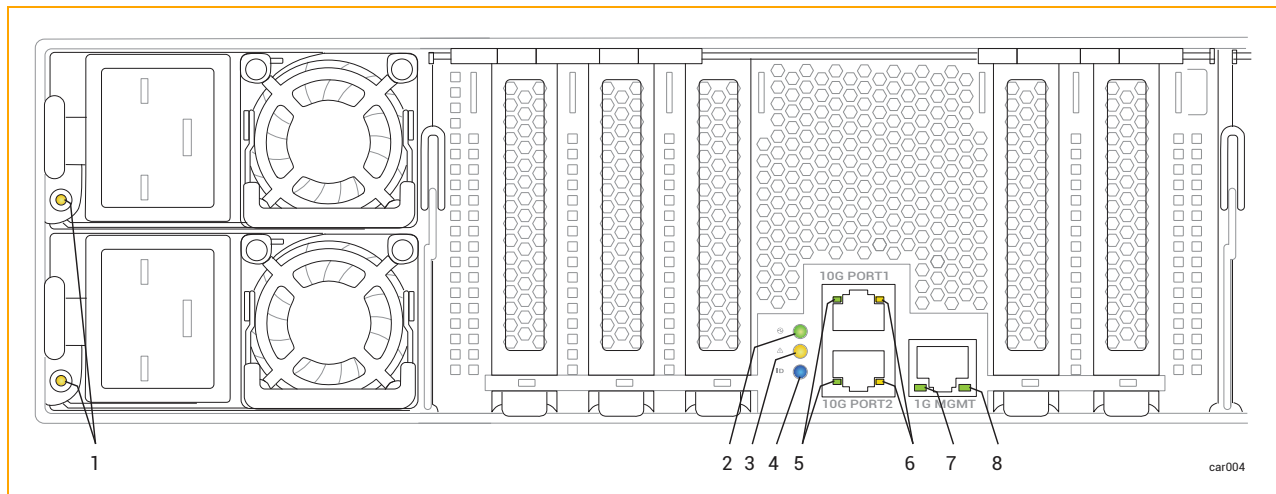

Table 4-4: Rear LEDs: PSUs

Callout	State	Description
1	Off	No AC power to any PSU.
	Solid green	Output power is on.
	Blinking green (1Hz)	The PSU is in a standby state: AC power is present at only 12Vsb.
	Blinking green (2Hz)	PSU firmware is updating.
	Solid amber	Indicates one of two scenarios: <ul style="list-style-type: none"> <li>The PSU has lost AC power (the AC cord might be unplugged); a second PSU still has AC power.</li> <li>A PSU critical event is causing a shutdown because of a failure, overcurrent, short circuit, over-voltage, fan failure, over-temperature, or some other reason.</li> </ul>
	Blinking amber (1Hz)	The PSU is still operating, though it is experiencing a warning event such as a high temperature, high power, high current, or a slow fan.

**Table 4-5: Rear LEDs: I/O Module**

Callout	LED	State	Description
2	PWR	Off	DC power and standby power to the module are off.
		Solid green	DC power to the module is on.
		Blinking green	Standby power to the system is on; DC power to the module is off.
3	ATTN	Off	<p>Indicates one of two scenarios:</p> <ul style="list-style-type: none"> <li>• The module does not need to be replaced.</li> <li>• The module needs to be replaced, but the module is not safe to remove.</li> </ul> <p>To determine which scenario is true, check the control-panel ear's ATTN LED. If that LED is not illuminated, no module in the system needs to be replaced.</p>
		Blinking amber	<p>Fault; safe to replace the module. LED illuminates with DC power or with standby power.</p> <p>To replace, see <a href="#">"Removing and Replacing an I/O Module"</a> on page</p>

Table 4-5: Rear LEDs: I/O Module

Callout	LED	State	Description
			119.
4	UID	Off	No request to identify module activated (normal operation).  To identify, see <a href="#">"Identifying a System or Component"</a> on page 250.
		Solid blue	Request to identify module activated; LED illuminates with DC power or with standby power.
5	10 Gbps Link /ACT	Off	No link is present.
		Solid green	Link is stable.
		Blinking green	Data is being transferred over the link.
6	10 Gbps Speed	Off	No link is present.
		Solid green	Connection speed is 10 Gbps.
		Solid amber	Connection speed is less than 10 Gbps.
7	1 Gbps Link /ACT	Off	No link is present.
		Solid green	Link is stable.
		Blinking green	Data is being transferred over the link.
8	1 Gbps Speed	Off	No link is present, or link speed is less than 1 Gbps.

**Table 4-5: Rear LEDs: I/O Module**

Callout	LED	State	Description
		Solid green	Connection speed is 1 Gbps.

**Using the ATTN LEDs to Diagnose Faults**

The ATTN LED on the control-panel ear and on the CRU modules help you diagnose faults. A *fault* is an issue that requires module replacement, as opposed to other types of errors that occur on a module (for example, correctable errors below a certain threshold) that do not require module replacement.

The examples in [Table 4-6](#) provide more information about using the ATTN LEDs to diagnose faults.

**Table 4-6: Examples of Faults**

ATTN LED Status	Explanation
Control-panel ear ATTN LED is blinking amber.  For all modules, ATTN LEDs are off.	One or more of the modules needs replacement or is not inserted, but no module that needs replacement is safe to remove.  For example, compute module A may need replacement, but it may still be the active compute module.
Control-panel ear ATTN LED is blinking amber.  Compute module A ATTN LED is blinking amber.  For all other modules, ATTN LEDs are off.	Compute module A needs replacement, and it is safe to remove. One or more of the other modules may need replacement or may not be inserted, but no module that needs replacement is safe to remove.  For example, storage module A may need replacement, but it may contain a non-mirrored disk.
Control-panel ear ATTN LED is blinking amber.  I/O module B ATTN LED is blinking amber.  For all other modules, ATTN LEDs are off.	I/O module B needs replacement, and it is safe to remove. One or more of the other modules may need replacement or may not be inserted, but no module that needs replacement is safe to remove.  For example, compute module A may need

ATTN LED Status	Explanation
	replacement, but it may still be the active compute module.

### Related Topics

- ["Identifying a System or Component" on page 250](#)
- ["System Front" on page 17](#)
- ["System Rear" on page 18](#)
- ["Planning a Site for ztC Endurance Systems" on page 35](#)
- ["Hardware Operation" on page 81](#)
- ["Removing and Replacing System Components" on page 97](#)
- ["Troubleshooting the Hardware" on page 85](#)

### Internal Disk Drive Problems and Solutions

[Table 4-7](#) lists some problems that the disk drives may encounter, as well as some corrective actions.

**Table 4-7: Troubleshooting Disk Drives**

Problem	Action
System will not boot from system disk	Try to boot from the system disk's mirrored partner. To do so, disengage the suspected faulty system disk by pulling it one to two inches (2.5 to 5 cm) out of the slot. See <a href="#">"Removing and Inserting a Disk Drive" on page 114</a> for more information.
System does not recognize disk drive	Ensure that the disk drive was installed correctly. See <a href="#">"Removing and Inserting a Disk Drive" on page 114</a> for more information.
Slow response time	<p>Mirror regeneration might be occurring. Try to schedule mirror regeneration for a time when the system is not heavily used. However, if the disk contains business-critical data, you should regenerate the mirrors as soon as possible.</p> <p>Many read or write operations might be queued to the disk drive.</p> <p>Errors might be occurring on the drive. Check the system event log.</p>

## Related Topics

- ["Disk Drives" on page 27](#)
- ["Storage Module" on page 26](#)
- ["Troubleshooting the Hardware" on page 85](#)

## Using the NMI Button

To enable your authorized Penguin Solutions service representative to diagnose problems with your system, you might need to create a dump file of the system's memory while the system is running.

One way to create a dump file is to press the NMI button (see [Figure 1-5](#)) on the active compute module.



**Notice:** Pressing the NMI button stops any running applications. Do not perform a dump operation if you want any applications to continue operating. Instead, schedule downtime for this procedure.

You may need to press the NMI button more than once to generate the dump signal. However, do not press the NMI button while a dump is in progress. This may result in an unusable dump.

## Related Topics

- ["System Front" on page 17](#)
- ["Compute Module" on page 21](#)

# 5

## Chapter 5: Removing and Replacing System Components

You can remove and replace many of the components of a ztC Endurance system. Before you remove or replace any system components, see ["General Servicing Information" on page 97](#).

To remove and replace system components, see:

- ["Preparing to Replace System Components" on page 101](#)
- ["Removing and Replacing a Compute Module" on page 103](#)
- ["Replacing, Adding, and Upgrading Memory" on page 106](#)
- ["Removing and Replacing a Storage Module" on page 112](#)
- ["Removing and Inserting a Disk Drive" on page 114](#)
- ["Removing and Replacing an I/O Module" on page 119](#)
- ["Removing and Installing a PCIe Adapter" on page 122](#)
- ["Removing and Replacing a PSU and Power Cords" on page 127](#)

### Related Topics

- ["System CRU Modules" on page 20](#)
- ["Troubleshooting the Hardware" on page 85](#)

### General Servicing Information

To perform general servicing tasks related to the unpacking, storing and repacking of system components, see:

- "Unpacking System Components" on page 98
- "Storing System Components" on page 99
- "Repacking System Components" on page 99
- "Replacing System Components" on page 100
- "General Safety Precautions" on page 101

## Unpacking System Components

When you receive a system component:

- Inspect the packing slip to ensure that the correct component was received.
- Inspect the packing container for damage.

Refer to the Warranty Parts Replacement Process and Return Instructions Web Site at <http://www.stratus.com/go/support/ftserver/warrantyreplace> if either of the following conditions applies to your shipment:

- You received the wrong shipment.
- The package is damaged.

If there are no problems, unpack the component.

### To unpack a system component

1. Observing any printed directions or warnings, carefully open the package.
2. Carefully remove the protective packaging and save it for possible reuse in storing or returning a component.
3. Verify that you received the correct component by checking the packing slip and the bar code label on the component.
4. Inspect the component for shipping damage.
5. If the component is wrapped in an antistatic bag, keep it in the bag until it is installed. If you are not going to install the component immediately, protect it from damage by repacking it in its shipping package.

### Related Topics

- "Removing and Replacing System Components" on page 97

## Storing System Components

If you need to store a system component, keep it in the protective packaging and take the following precautions:

- Ensure that the component is right-side up by following the directions on the package.
- Comply with all warning labels.
- Avoid placing the component in a location where heavier items might be placed on it.
- Protect the component from exposure to dust, electromagnetic fields, vibrations, extreme heat, or any other environmental conditions that might damage the component.
- Avoid prolonged storage that could reduce the useful life of the component.

If you are uncertain about the proper storage conditions for a specific component, see ["Getting Help" on page 293](#). Also, see ["Preparing to Replace System Components" on page 101](#) for information about how to protect components from exposure to static electricity.

### Related Topics

- ["Removing and Replacing System Components" on page 97](#)

## Repacking System Components

When returning a defective or incorrect system component, package the component using the original packing materials or the replacement-component packing materials. Ensure that the component is adequately protected from the following:

- Dents, scratches, and impact damage
- Static electricity (using the pink or blue electrostatic discharge (ESD) bag)
- Accidental opening of the package in transit
- Detachment of the address label

If you are uncertain that the component will be adequately protected during shipment, see ["Getting Help" on page 293](#).

### Related Topics

- ["Removing and Replacing System Components" on page 97](#)

## Replacing System Components

**Caution:** Do not remove or service any I/O modules, storage modules, or compute modules if the ztC Endurance console is reporting any PSU faults.



You must first restore full PSU functionality to both PSUs before removing any other modules for additional service (that is, the LED on both PSUs must be solid green).

**In extreme circumstances, failure to follow this service sequence may result in compromised power integrity to the ztC Endurance system.**

**Caution:** Ne retirez ni ne procédez à l'entretien d'aucun module d'E/S, de stockage ou de calcul si la console ztC Endurance signale une défaillance d'un bloc d'alimentation.



Vous devez d'abord rétablir le bon fonctionnement des deux blocs d'alimentation avant de retirer tout autre module pour un entretien supplémentaire (autrement dit, les voyants DEL des deux blocs d'alimentation doivent rester allumés en vert sans clignoter).

**Dans des situations extrêmes, le non-respect de cette séquence d'entretien risque de compromettre l'intégrité de l'alimentation électrique du système ztC Endurance.**

Before replacing a system component, do the following:

- Confirm that the component has failed and needs to be replaced. You can view failure information from the status LEDs on each component, from your system's event or error logs, and from viewing the **Dashboard** page of the ztC Endurance console.
- Determine if a component needs to be taken out of service, and then remove it from service as described in ["Using Maintenance Mode" on page 250](#).
- Observe the proper safety precautions by following the precautions listed in ["General Safety Precautions" on page 101](#).

After replacing a component, do the following:

1. Place the component in service if it is out of service as described in ["Using Maintenance Mode" on page 250](#).
2. Verify system operation.
3. Package and ship the failed component. See ["Repacking System Components" on page 99](#).

### Related Topics

- ["Removing and Replacing System Components" on page 97](#)
- ["Status LEDs" on page 86](#)
- ["Dashboard Page" on page 241](#)

### General Safety Precautions

- To help identify problems that might occur during the removal and replacement of system components, read the entire procedure before performing it.
- Provide enough space and light to perform the procedure safely and accurately.
- Conduct all activities in compliance with all applicable industry safety standards and practices.
- Take proper grounding precautions. When handling components, especially those with exposed integrated circuits, use proper grounding procedures to avoid ESD damage to the component. See the information about using ESD precautions in ["Safety Precautions" on page 49](#).
- When performing maintenance procedures, do not wear conductive articles or material such as rings, bracelets, keys, chains, garments with metallic thread, and other similar items.

### Related Topics

- ["Safety Precautions" on page 49](#)

### Preparing to Replace System Components

No tools are required to replace customer-replaceable components in a ztC Endurance system.

Working on the physical system can expose electronic components to potential damage from electrostatic discharge (ESD). Whenever working on a system:

- [Use ESD precautions.](#)
- [Observe all notes, notices, cautions, and warnings.](#)

## Using ESD Precautions

**Notices:** To avoid damaging ESD-sensitive components during handling, always take the following precautions.



- Ground yourself before working with system components. Put a grounding strap on your wrist and attach its other end to some suitable grounding point, such as a computer-system cabinet.
- Discharge static electricity by touching an unpainted portion of the system just before handling ESD-sensitive parts.
- Store PCIe adapters in their static-protective envelope until you are ready to install them in the system.
- Hold a PCIe adapter by its edges.

## Observing Cautions and Warnings

Observe the following warnings, cautions, notices, and notes.



**Warning:** If a component is not customer-replaceable, do not attempt to remove or replace it. Doing so may result in serious personal injury and/or damage to the system.



**Avertissement:** Si un composant n'est pas remplaçable par le client, n'essayez pas de le retirer ou de le remplacer. Cela pourrait provoquer des blessures graves et/ou endommager le système.

**Notices:** When replacing a system component, always observe the following guidelines.



- Remove a component only when its status LEDs indicate that it is safe to remove. See "[Status LEDs](#)" on page 86 for information about each component's status LEDs.
- When necessary, see "[Status LEDs](#)" on page 86 to learn how to identify a failed component and take it offline before servicing it.
- Read the entire procedure so that you fully understand it. If any part of the procedure is not clear, see "[Getting Help](#)" on page 293.

## Related Topics

- ["Safety Precautions" on page 49](#)
- ["General Safety Precautions" on page 101](#)

## Removing and Replacing a Compute Module

### Cautions:



1. Use [ESD precautions](#) when performing these procedures.
2. Read ["Replacing System Components" on page 100](#) before you remove any system components.

### Précautions:



1. Utilisez les précautions ESD lors de l'exécution de ces procédures.
2. Lisez ["Replacing System Components" on page 100](#) avant de retirer des composants du système.

## To remove a compute module

1. Place the compute module into maintenance mode as described in ["Using Maintenance Mode" on page 250](#).
2. After the compute module is in maintenance mode, shut it down as described in ["Shutting Down and Restarting a Compute Module" on page 252](#).
3. Disconnect all cables from the compute module.
4. Use your index finger to unlatch the release lever on the compute module.
5. Grasp the release lever and pull it away from the system chassis until the module extends an inch or two from the system chassis. See [Figure 5-1](#).

**Figure 5-1: Removing Compute Module**

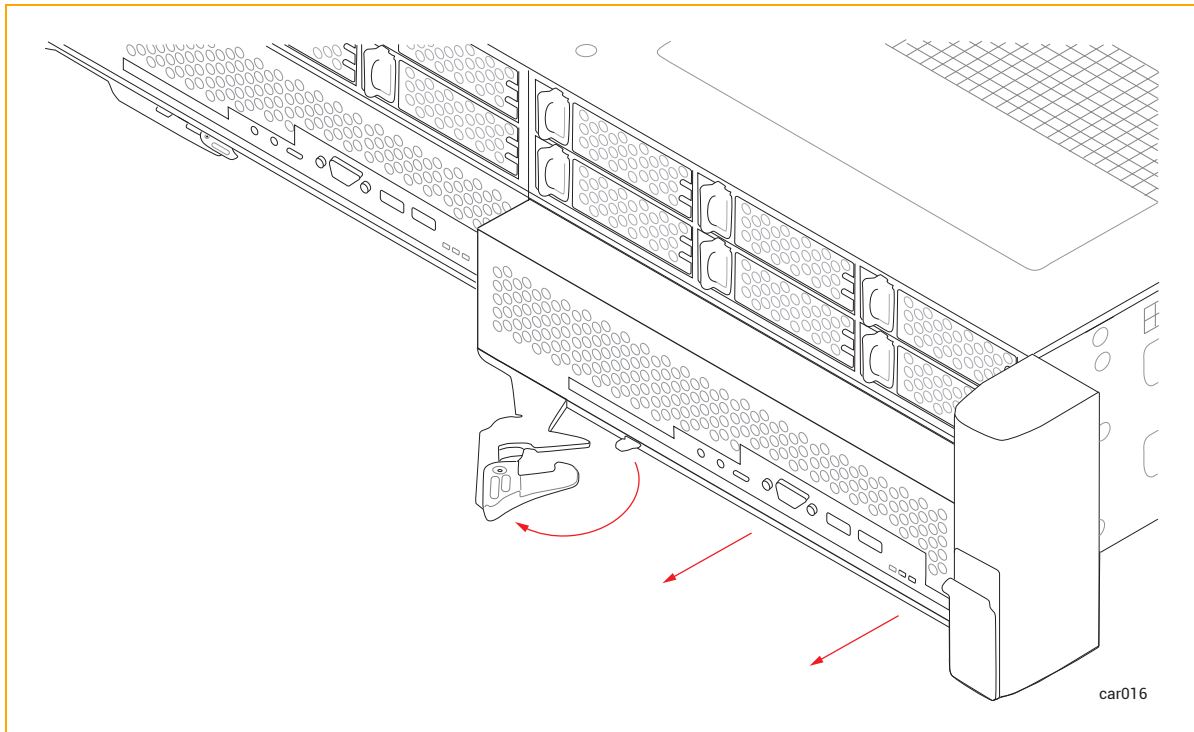

6. Holding the module on each side, pull it straight out of the system chassis and place it on a flat, stable surface.

### To replace a compute module



**Caution:** Make sure that the left compute module is fully inserted and latched before you remove the right compute module. Otherwise, damage can result, and the right compute module cannot be removed.



**Précaution:** Assurez-vous que le module de calcul de gauche est complètement inséré et verrouillé avant de retirer le module de calcul de droite. Sinon, des dommages peuvent en résulter et le module de calcul de droite ne peut pas être retiré.

1. Check the "[Hardware Page](#)" on [page 245](#) of the ztC Endurance console to make sure that the compute module is in maintenance mode.
2. Extend the release lever on the compute module to the left until it is fully open.
3. Holding the compute module on each side, slide it into one of the bottom slots until it stops. Ensure that the module is fully seated and aligns with the system chassis.

4. Push on the center of the compute module with one hand while simultaneously using your other hand to push the release lever toward the system chassis until it clicks. See [Figure 5-2](#).

**Figure 5-2: Replacing Compute Module**

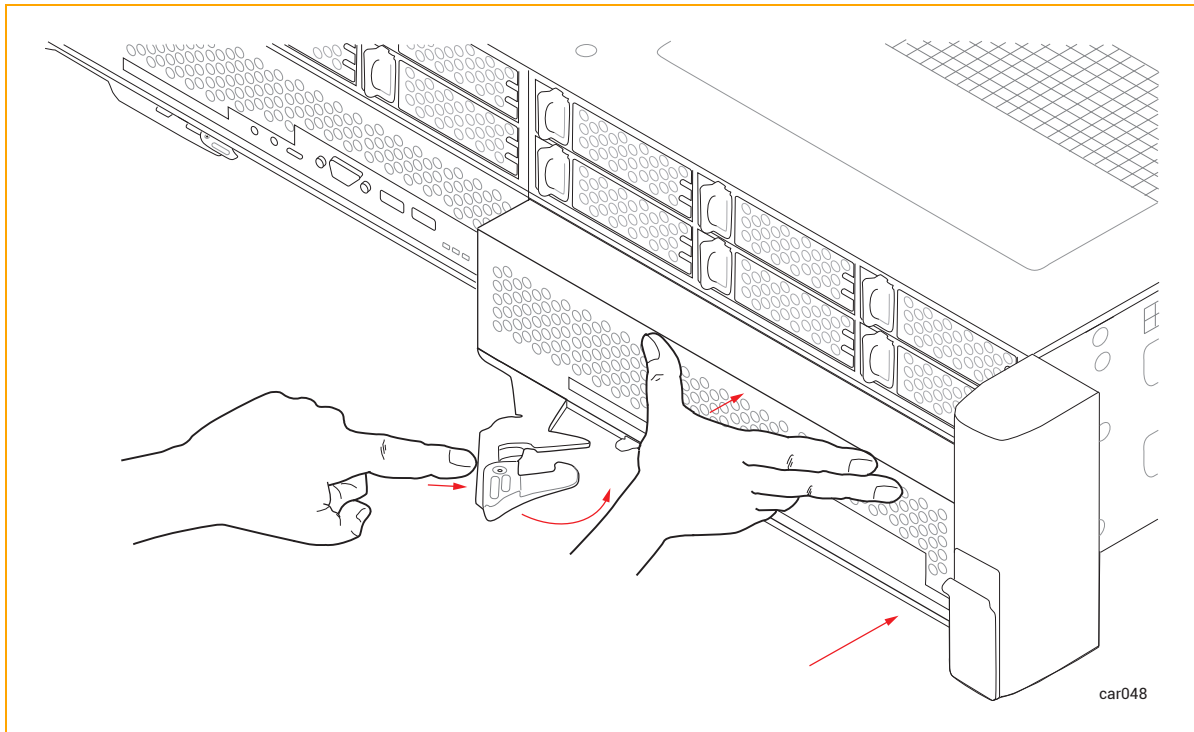

5. Push on the center of the compute module once more to make sure it is fully seated in the system chassis.
6. Connect all of the cables.
7. Remove the compute module from maintenance mode as described in ["Using Maintenance Mode"](#) on page 250.



**Notice:** If you insert a replacement compute module but do not remove it from maintenance mode, the system software cannot update the BMC, BIOS, or Standby OS. The system software also posts an alert to indicate that it cannot update the standby compute module until maintenance mode is cleared.

8. Reset the network settings for the compute module.



**Notice:** Until you run the `zen_team.ps1 update` command, the network interfaces are not teamed, and the associated I/O modules and PCIe devices appear as **simplex** in the ztC Endurance console.

- a. Prepare to run the `zen_team.ps1` teaming script as described in ["Using the LBFO Teaming Script to Manage Ethernet Teams" on page 196](#).
- b. Run the teaming script with the update option:

```
> & 'C:\Program Files\Stratus\bin\zen_team.ps1' update
```

- c. After the teaming script has completed, close the PowerShell utility.

## Related Topics

- ["Compute Module" on page 21](#)
- ["Memory in ztC Endurance Systems" on page 22](#)

## Replacing, Adding, and Upgrading Memory

Replacing, adding, and upgrading ztC Endurance system memory involves removing and installing the DIMMs that are housed on ztC Endurance compute modules. Before working with DIMMs, read ["Memory in ztC Endurance Systems" on page 22](#).

This section describes:

- ["Terminology for Memory Procedures" on page 106](#)
- ["Important Cautions and Notes" on page 107](#)
- ["Replacing DIMMs" on page 107](#)
- ["Adding DIMMs" on page 109](#)

## Terminology for Memory Procedures

Before adding memory to the ztC Endurance system or replacing existing DIMMs, review the following terms to understand how they are used in this guide:

- **Adding** – Increasing the quantity of DIMMs on the ztC Endurance system by inserting additional DIMMs in empty slots on the compute module.

When you add memory, you must add DIMMs to both compute modules. See ["Memory in ztC Endurance Systems" on page 22](#) for DIMM locations for your configuration.

- **Upgrading** – Increasing the total memory capacity of the ztC Endurance system by replacing an existing DIMM with a higher capacity DIMM (currently, the ztC Endurance system supports only 64GB DIMMs, but higher-capacity DIMMs may be supported in the future).
- **Replacing** – Removing an installed DIMM from a compute module and inserting a different DIMM in the same slot.

- **Removing** – Removing an existing DIMM from its slot on the ztC Endurance compute module.
- **Installing** – Inserting a DIMM in an empty slot on the ztC Endurance compute module.

## Important Cautions and Notes

### Cautions:



1. Use [ESD precautions](#) when performing these procedures.
2. Read "[Replacing System Components](#)" on page 100 before you remove any system components.

### Précautions:



1. Utilisez les précautions ESD lors de l'exécution de ces procédures.
2. Lisez "[Replacing System Components](#)" on page 100 avant de retirer des composants du système.



**Note:** Replacing DIMMs does not require a system shutdown because you remove only one compute module at a time.



**Notice:** If you require assistance while adding DIMMs, your authorized Penguin Solutions service representative can provide onsite installation services for a fee.

## Replacing DIMMs

To replace a DIMM on a ztC Endurance compute module, follow the instructions below and in the following section, "[Adding DIMMs](#)" on page 109.

### To replace a DIMM

1. [Remove the compute module](#) that houses the DIMM you want to replace.
2. Place the compute module on a firm surface.
3. Using the information in "[Memory in ztC Endurance Systems](#)" on page 22, determine:
  - The slots in which DIMMs are currently installed
  - The correct slot in which to insert the new DIMM
4. Facing the front of the compute module:

- If you are removing and replacing a DIMM on the left side of the compute module, remove the small baffle to the left of the DIMMs by gently pulling up one side of the baffle and then the other side. See [Figure 5-3](#).

**Figure 5-3: Removing Small Baffle**

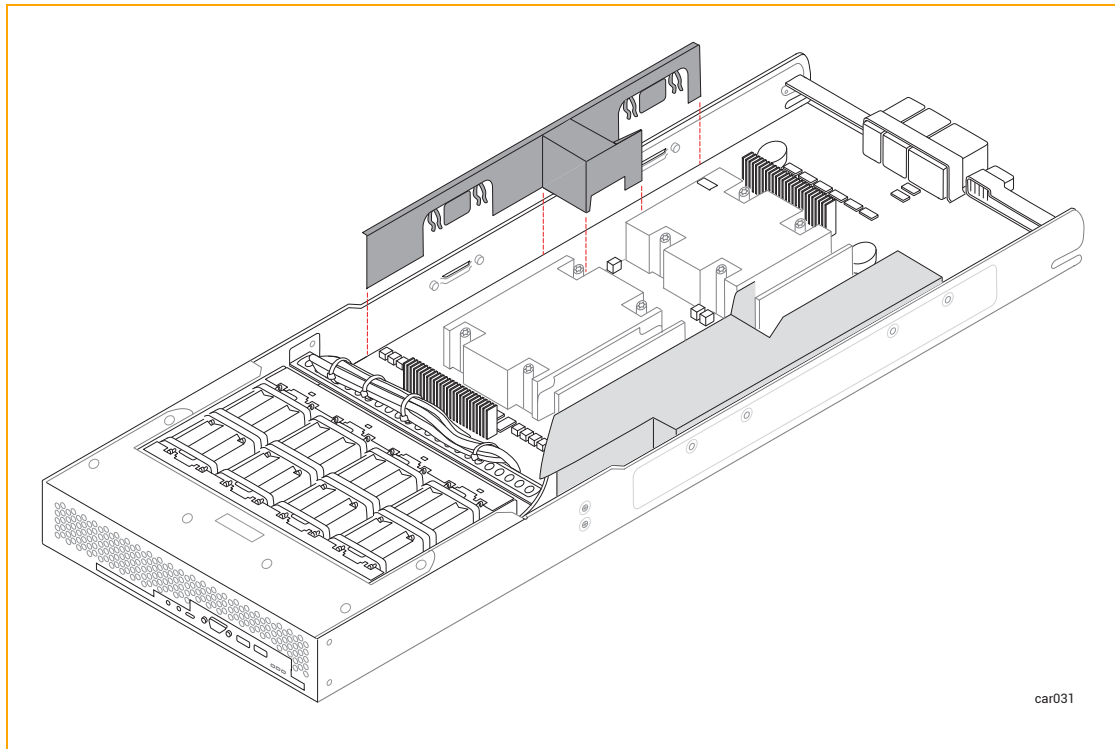

- If you are replacing a DIMM on the right side of the compute module, you do not need to remove the large baffle. Proceed to the next step.
5. Push down on the ejector levers at each end of the DIMM to be removed. See [Figure 5-4](#).

Figure 5-4: Removing DIMM

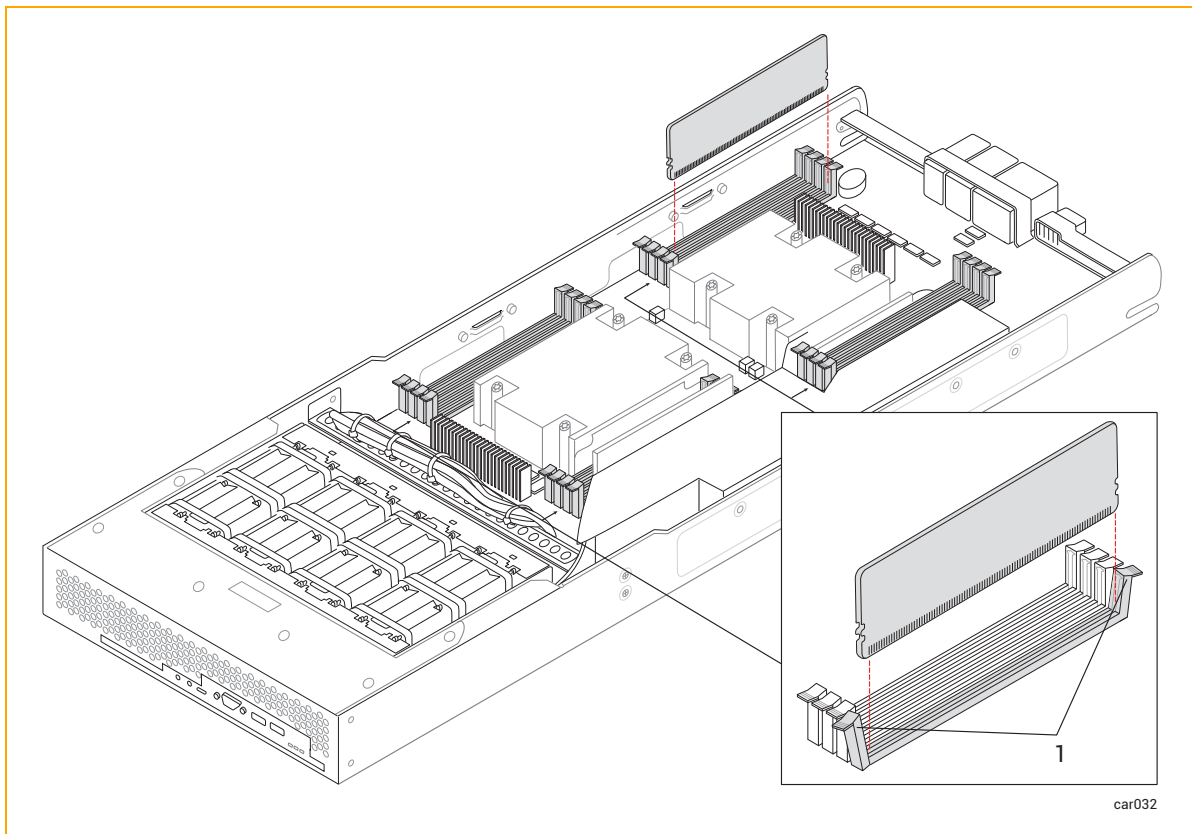

1 Ejector levers

6. Pull the DIMM straight up to remove it from the connector.

To install the new DIMM, proceed to the next section, ["Adding DIMMs" on page 109](#).

## Adding DIMMs

You add a DIMM to a ztC Endurance compute module to increase the amount of system memory, or to replace an existing, faulty DIMM.

When you add memory, you must add DIMMs to both compute modules. See ["Memory in ztC Endurance Systems" on page 22](#) for DIMM locations for your configuration.

### To insert a DIMM into a compute module

If you are inserting a DIMM in the same slot from which you just removed one, as described in ["Replacing DIMMs" on page 107](#), proceed to Step 6 in the following procedure.

1. Perform a total shutdown of the ztC Endurance server using the **Shutdown** button on the ztC Endurance console **Dashboard** page.



**Notice:** Do not click the **Shutdown** button unless you are familiar with the topics discussed in "System Power" on page 82.

2. [Remove the compute module](#) that houses the DIMM you want to replace.
3. Place the compute module on a firm surface.
4. Using the information in "[Memory in ztC Endurance Systems](#)" on page 22, determine the correct slot in which to insert the new DIMM.
5. Facing the front of the compute module:
  - If you are adding a DIMM to the left side of the compute module, remove the small baffle to the left of the DIMMs by gently pulling up one side of the baffle and then the other side. See [Figure 5-3](#) in "[Replacing DIMMs](#)" on page 107.
  - If you are replacing a DIMM on the right side of the compute module, you do not need to remove the large baffle. Proceed to the next step.
6. Push down on the ejector levers at each end of the slot in which the DIMM will be inserted. See [Figure 5-4](#) in "[Replacing DIMMs](#)" on page 107.
7. With the DIMM connector ejector levers in the open position (down), align the small slots on the base of the DIMM with the notches at the base of the connector. The DIMMs product label must face the direction indicated by the arrows in [Figure 5-5](#).

Figure 5-5: Direction of DIMM Product Labels

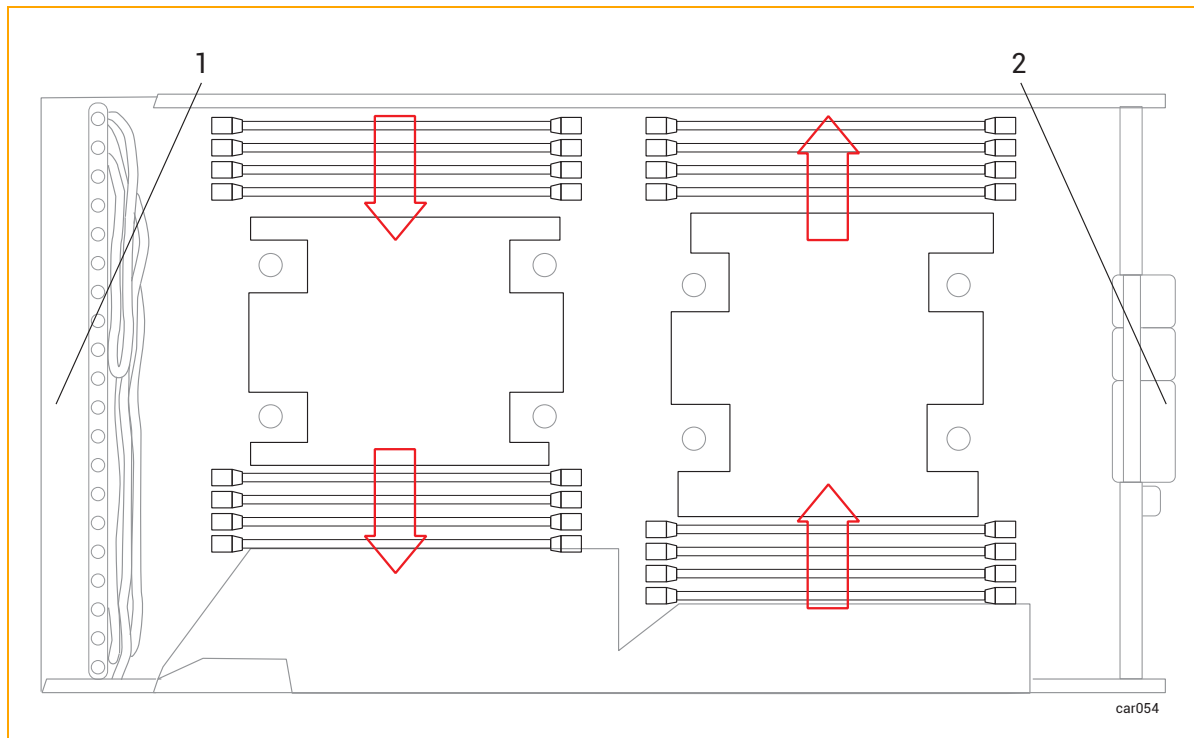

- |   |                         |
|---|-------------------------|
| 1 | Front of compute module |
| 2 | Rear of compute module  |

8. Push the DIMM down firmly into place. Make sure it is fully seated.



**Caution:** Ensure that the DIMM product label is facing the correct direction and the connector notches are properly aligned before seating the DIMM. Do not force.



**Précaution:** Assurez-vous que l'étiquette du produit DIMM est orientée dans la bonne direction et que les encoches du connecteur sont correctement alignées avant d'insérer le DIMM. Ne forcez pas.

9. Ensure that the connector's ejector levers are raised and fully locked into place. If they are not, eject and reseat the DIMM.
10. Optionally, repeat Steps 6 through 9 for any additional DIMMs.
11. If you removed the small baffle earlier, replace it by aligning the curved clips with the metal mounting pins on the side wall of the chassis. Push down firmly.

12. After installing the DIMMs, [replace the compute module](#).
13. Repeat this procedure from step 1 to add the required corresponding DIMM to the other compute module.
14. Power on the ztC Endurance system.
15. Watch the BIOS display for each compute module as it runs its Power-On Self-Test (POST) routine to ensure that the memory matches the expected configuration. Alternatively, when the system has booted to the operating system, you can use the ztC Endurance console to verify the memory configuration.

### Related Topics

- ["Memory in ztC Endurance Systems" on page 22](#)
- ["Compute Module" on page 21](#)

### Removing and Replacing a Storage Module

#### Cautions:



1. Use [ESD precautions](#) when performing these procedures.
2. Read ["Replacing System Components" on page 100](#) before you remove any system components.

#### Précautions:



1. Utilisez les précautions ESD lors de l'exécution de ces procédures.
2. Lisez ["Replacing System Components" on page 100](#) avant de retirer des composants du système.

### To remove a storage module

1. Use your index finger to unlatch the release lever on the storage module.
2. Grasp the release lever and pull it away from the system chassis until the storage module extends an inch or two from the system chassis. See [Figure 5-6](#).

Figure 5-6: Removing Storage Module

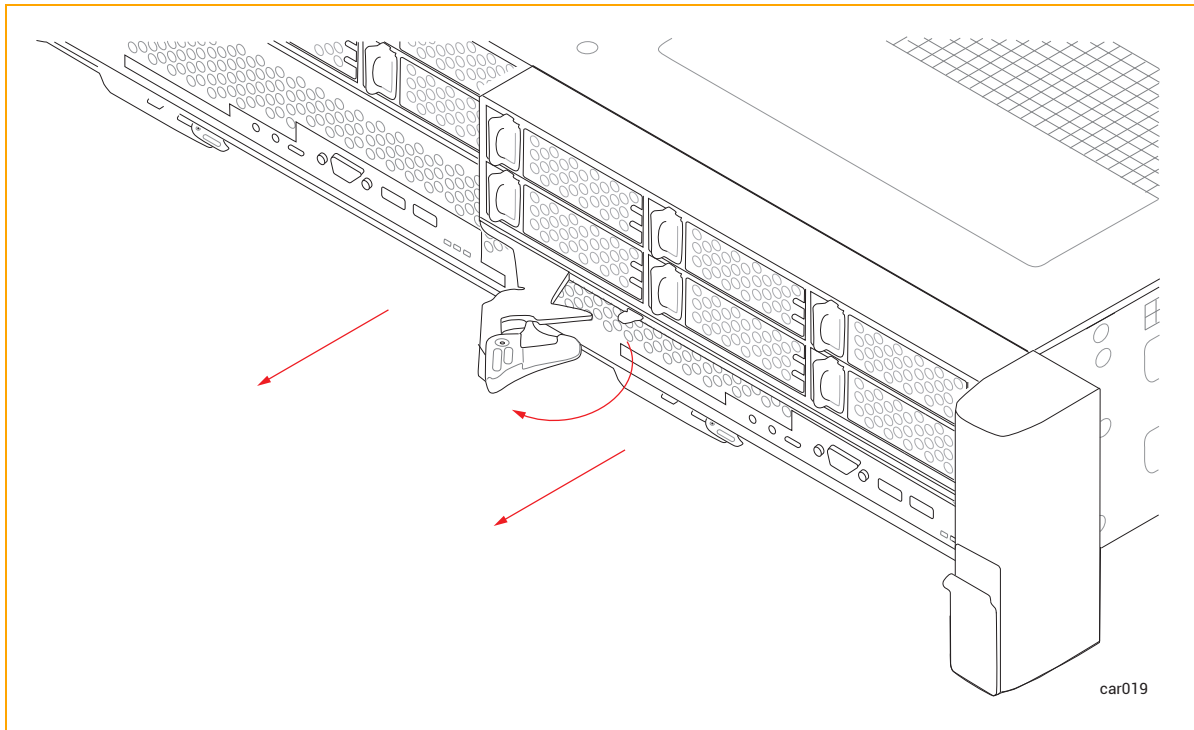

3. Holding the storage module on each side, pull it straight out of the system chassis and place it on a flat, stable surface.

### To replace a storage module



**Caution:** Make sure that the left storage module is fully inserted and latched before you remove the right storage module. Otherwise, damage can result, and the right storage module cannot be removed.



**Précaution:** Assurez-vous que le module de stockage de gauche est complètement inséré et verrouillé avant de retirer le module de stockage de droite. Sinon, des dommages peuvent en résulter et le module de stockage droit ne peut pas être retiré.

1. Extend the release lever on the storage module to the left until it is fully open.
2. Holding the storage module on each side, slide it into one of the top slots until it stops. Ensure that the module is fully seated and aligns with the system chassis.
3. Push on the center of the storage module with one hand while simultaneously using your other hand to push the release lever toward the system chassis until it clicks. See [Figure 5-7](#).

**Figure 5-7: Replacing Storage Module**

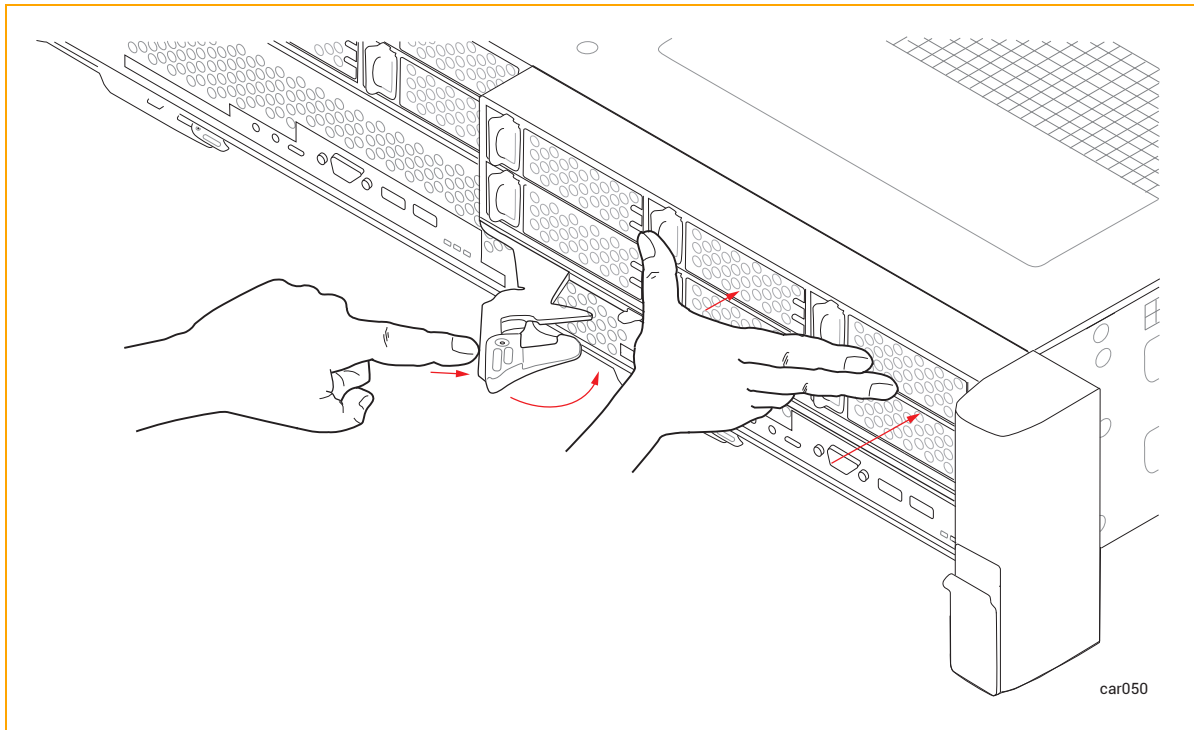

4. Push on the center of the storage module once more to make sure it is fully seated in the system chassis.

#### Related Topics

- ["Storage Module" on page 26](#)
- ["Removing and Inserting a Disk Drive" on page 114](#)

#### Removing and Inserting a Disk Drive

You can remove disk drives from a storage module to replace them or to perform other maintenance procedures. You do not need to power down or remove the storage module to perform this procedure.



**Caution:** Use [ESD precautions](#) when performing these procedures.



**Précaution:** Utilisez les précautions ESD lors de l'exécution de ces procédures.

## To remove a disk drive

1. Slide the button on the release lever to the left until the release lever opens. See [Figure 5-8](#).

**Figure 5-8: Removing Disk Drive**

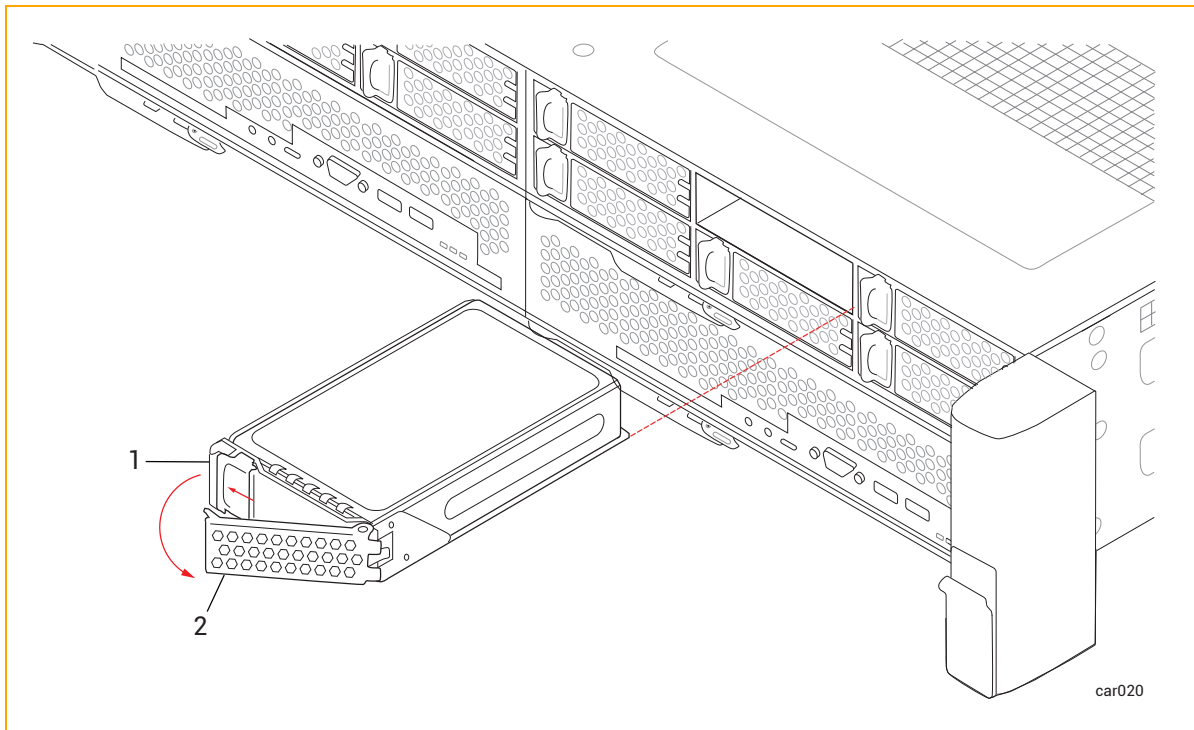

- |   |                |
|---|----------------|
| 1 | Release button |
| 2 | Release lever  |

2. Pull the release lever and remove the disk drive.

## To insert a disk drive



**Note:** You should be familiar with the information provided in "Disk Drives" on page 27 before you insert a disk drive.

1. With the release lever in the fully open position, insert the disk drive into the slot at the slight angle shown in [Figure 5-9](#). Stop when approximately three inches of the disk drive extend from the slot.

**Figure 5-9: Inserting Disk Drive: Step 1**

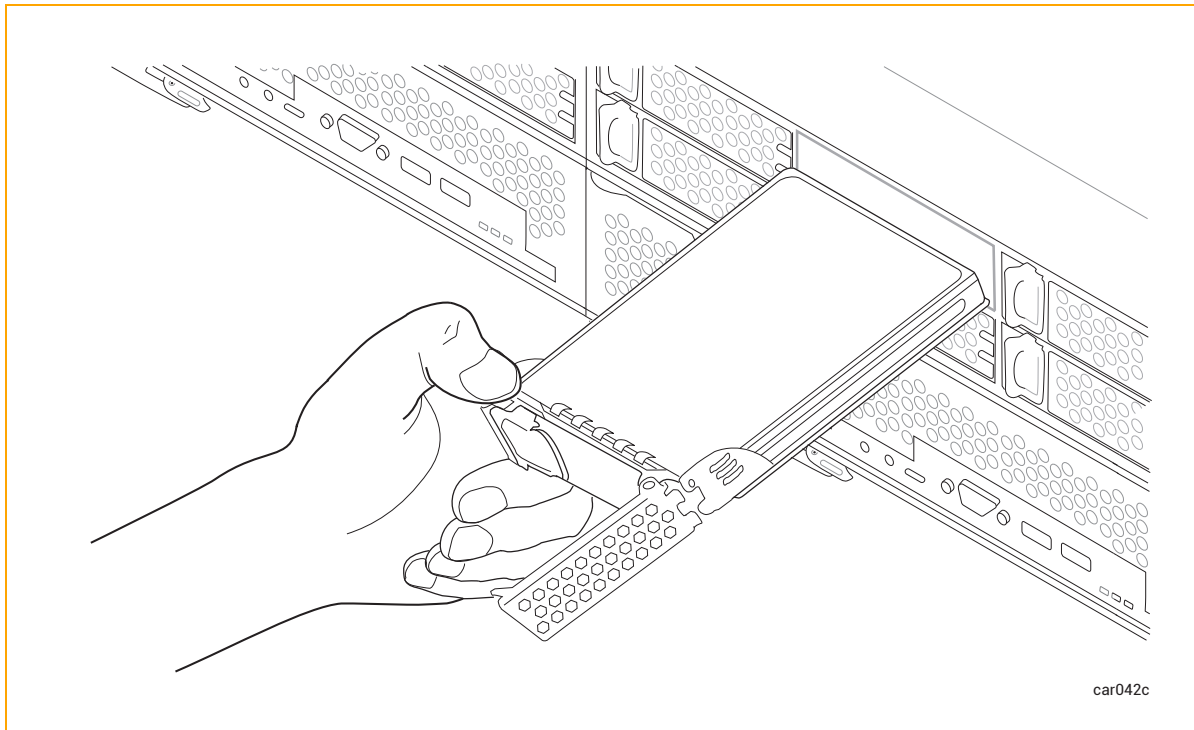

2. With the release lever still in the fully open position, use your left thumb to apply pressure on the release button while slowly inserting the disk drive into the slot. Stop when the two tabs on the right side of the release lever are flush with the slot opening. See [Figure 5-10](#).

Figure 5-10: Inserting Disk Drive: Step 2

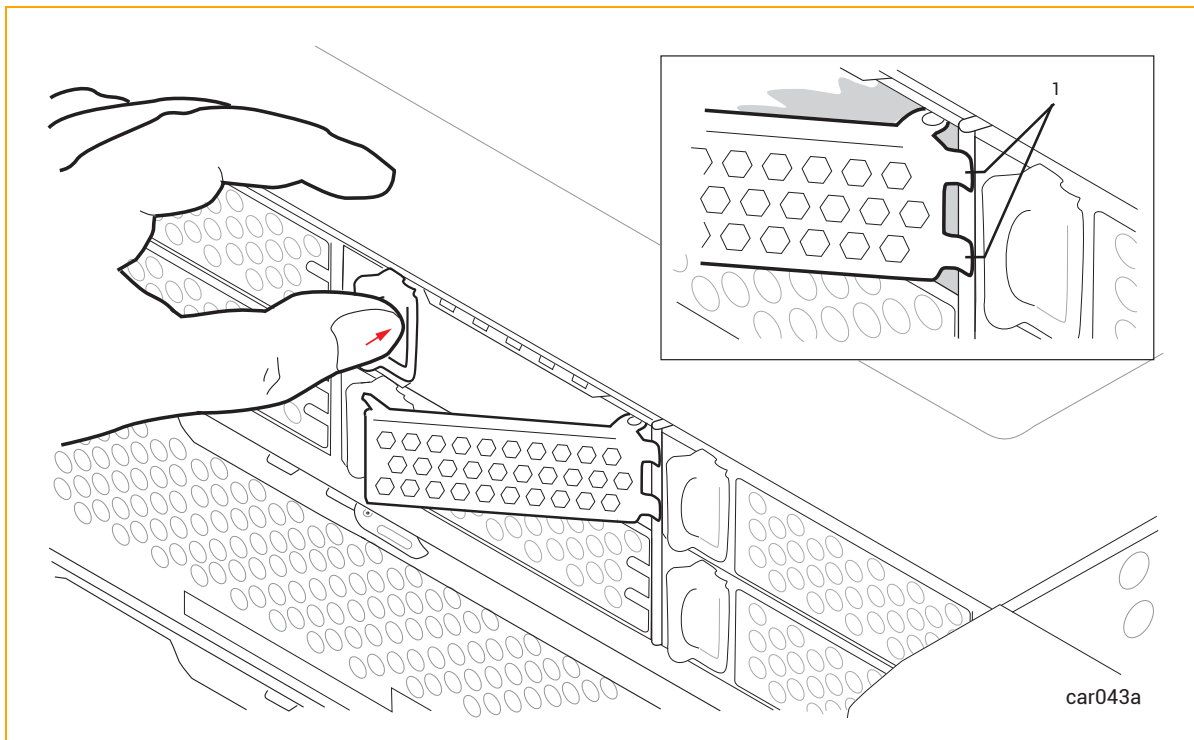

1 Tabs

3. While continuing to apply pressure to the release button with your left thumb, use your right thumb to push the release lever until it locks into place. See [Figure 5-11](#).

**Figure 5-11: Inserting Disk Drive: Step 3**

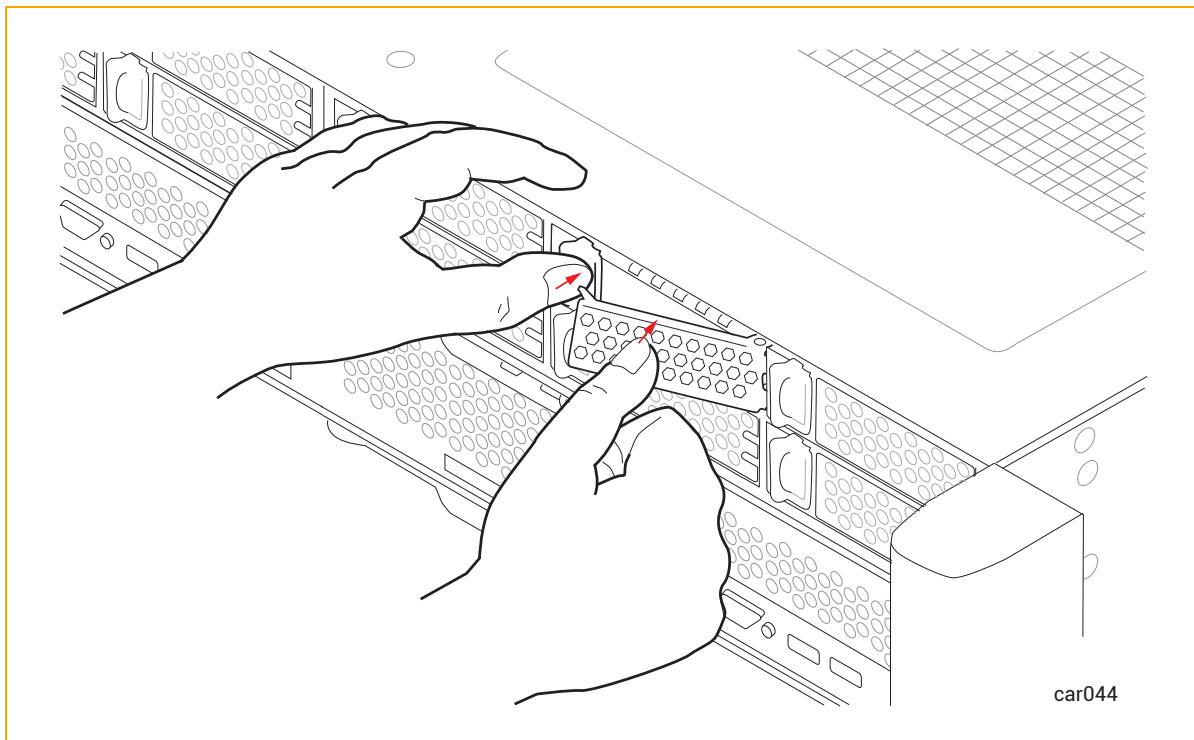

4. Push firmly again to make sure that the disk drive is fully seated. See [Figure 5-12](#).

Figure 5-12: Inserting Disk Drive: Step 4

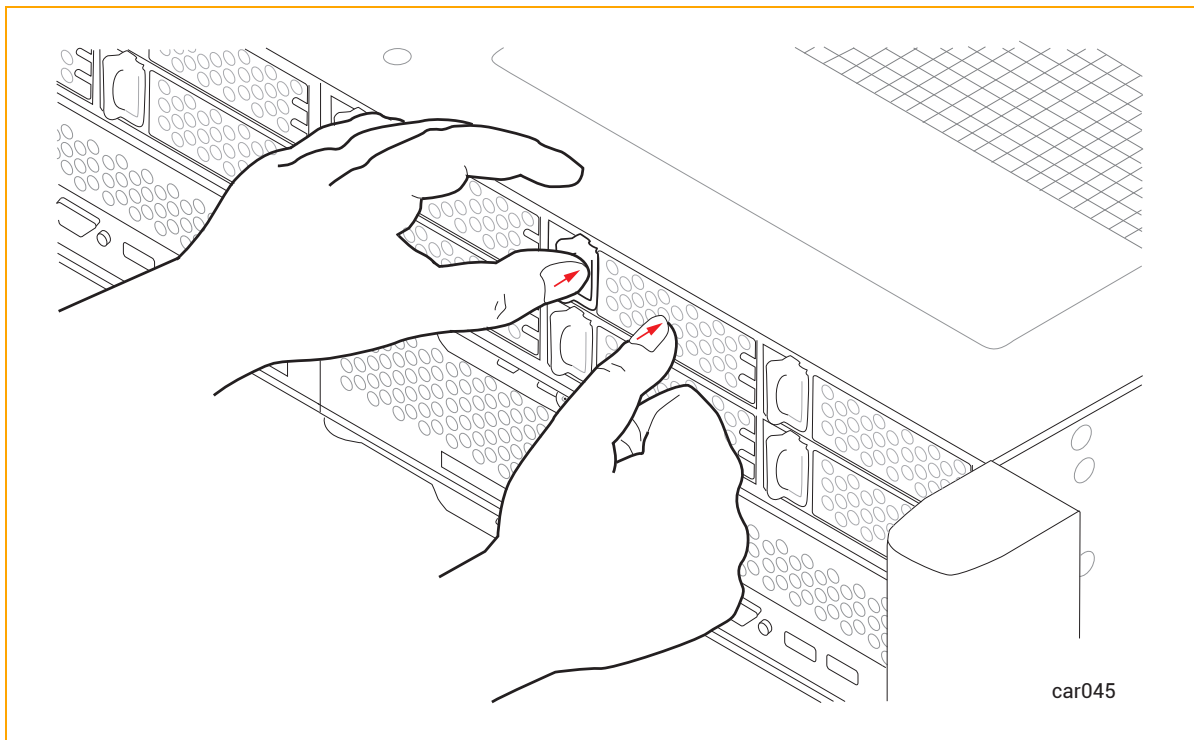

5. If the ztC Endurance system is powered on, check the disk drive's [ACT LED](#). If the LED is solid green, the disk drive is inserted correctly. If the LED is off, the disk drive is not inserted correctly; remove the disk drive and repeat this procedure.

#### Related Topics

- ["Disk Drives"](#) on page 27
- ["Internal Disk Drive Problems and Solutions"](#) on page 95
- ["Storage Module"](#) on page 26
- ["System Specifications"](#) on page 287

#### Removing and Replacing an I/O Module

##### Cautions:



1. Use [ESD precautions](#) when performing these procedures.
2. Read ["Replacing System Components"](#) on page 100 before you remove any system components.

**Précautions:**



1. Utilisez les précautions ESD lors de l'exécution de ces procédures.
2. Lisez "[Replacing System Components](#)" on page 100 avant de retirer des composants du système.

**To remove an I/O module**

1. Disconnect all cables from the I/O module.
2. Use your index finger to unlatch the release lever on the I/O module.
3. Grasp the release lever and pull it down until it is fully extended and the I/O module extends an inch or two from the system chassis. See [Figure 5-13](#).

**Figure 5-13: Removing I/O Module**

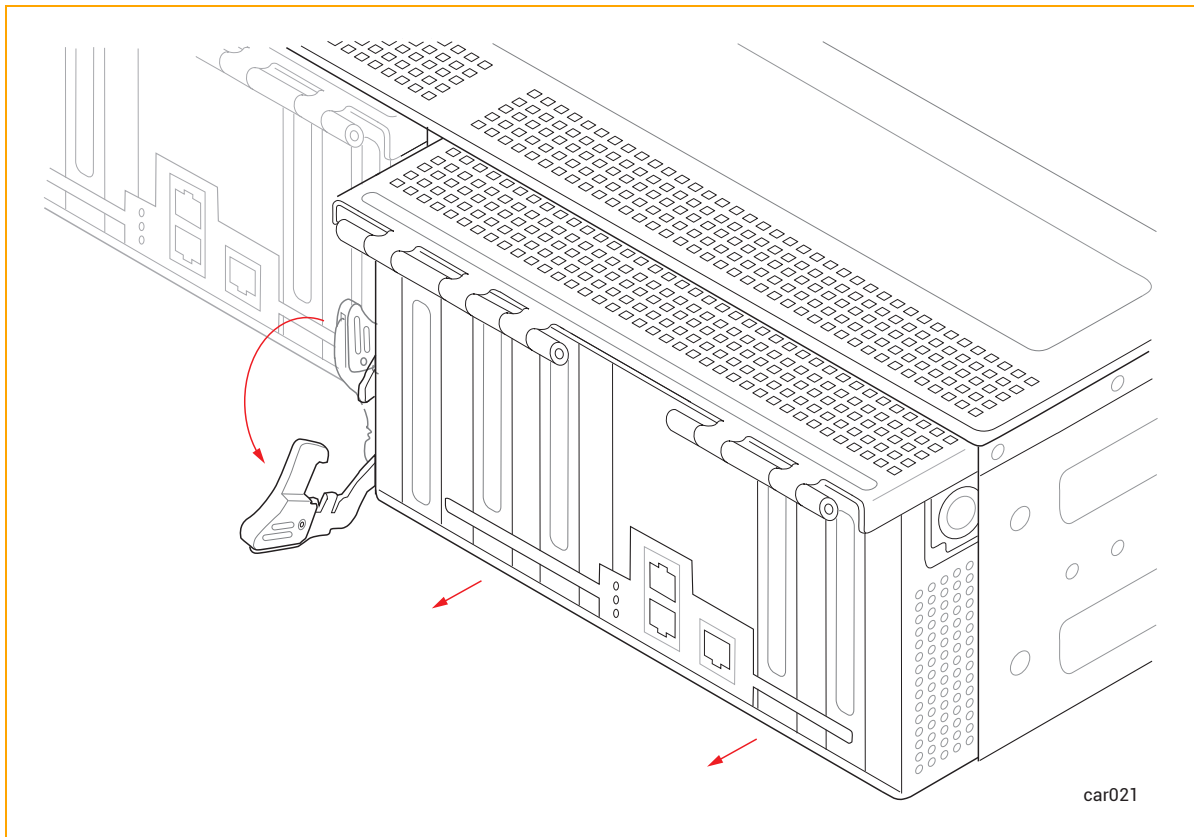

**Caution:** The release lever must be fully extended as shown in the figure before you perform step 4.



**Précaution:** Le levier de déverrouillage doit être complètement étendu comme indiqué sur la figure avant d'effectuer l'étape 4.

4. Holding the I/O module on each side, pull it straight out of the system chassis and place it on a flat, stable surface.

### To replace an I/O module

1. Extend the release lever on the I/O module until it is fully open.
2. Slide the I/O module into the system chassis until it stops. Ensure that the module is fully seated and aligns with the system chassis.
3. Push on the center of the I/O module with one hand while simultaneously using your other hand to push up the release lever until it clicks. See [Figure 5-14](#).

**Figure 5-14: Replacing I/O Module**

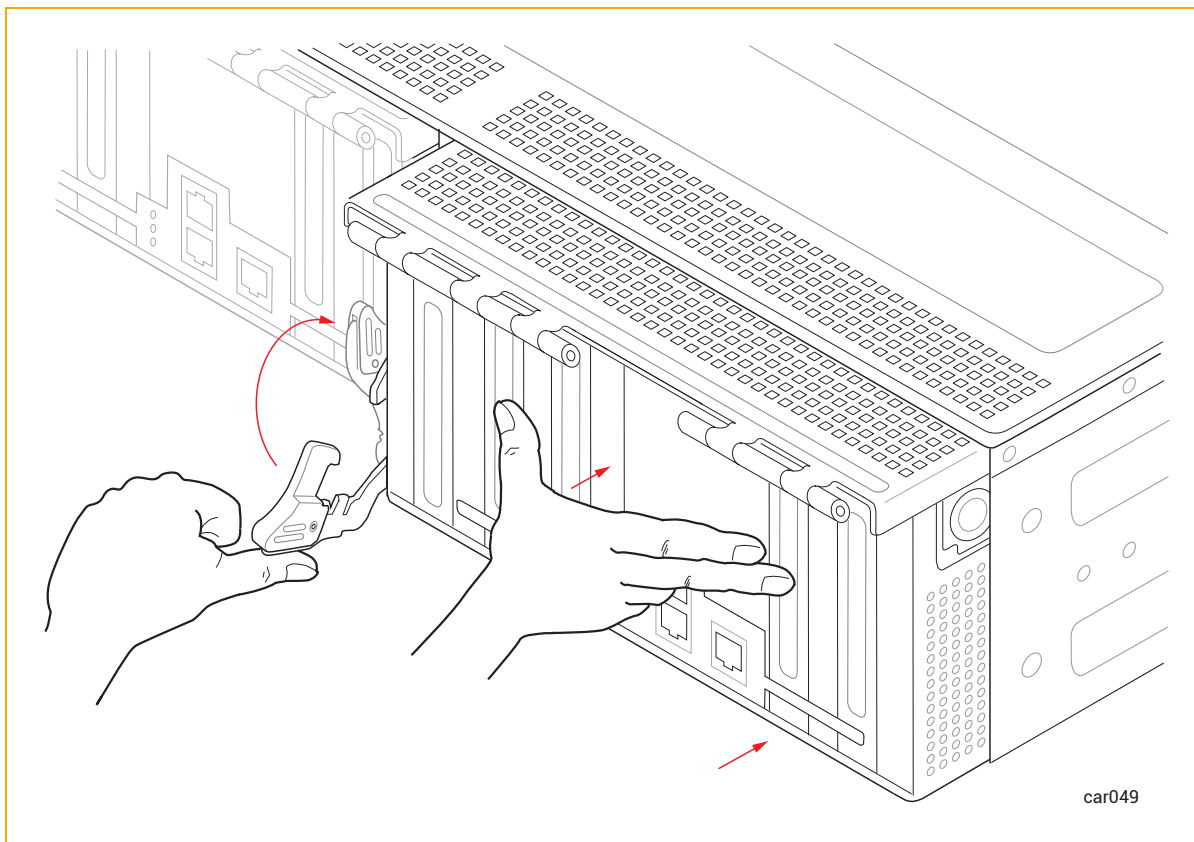

4. Push on the center of the I/O module once more to make sure it is fully seated in the system chassis.
5. Connect all of the cables.

6. Reset the network settings for the I/O module.



**Notice:** Until you run the `zen_team.ps1 update` command, the network interfaces are not teamed, and the associated I/O modules and PCIe devices appear as **simplex** in the ztC Endurance console.

- a. Prepare to run the `zen_team.ps1` teaming script as described in "Using the LBFO Teaming Script to Manage Ethernet Teams" on page 196.
- b. Run the teaming script with the update option:

```
> & 'C:\Program Files\Stratus\bin\zen_team.ps1' update
```

- c. After the teaming script has completed, close the PowerShell utility.

### Related Topics

- "I/O Module" on page 29
- "Removing and Installing a PCIe Adapter" on page 122
- "PCIe Adapters" on page 30

### Removing and Installing a PCIe Adapter

#### Cautions:



1. Use [ESD precautions](#) when performing these procedures.
2. Read "Replacing System Components" on page 100 before you remove any system components.

#### Précautions:



1. Utilisez les précautions ESD lors de l'exécution de ces procédures.
2. Lisez "Replacing System Components" on page 100 avant de retirer des composants du système.

**Notes:**

1. You do not need to shut down a ztC Endurance system when you remove or install PCIe adapters. You simply remove one I/O module, remove/install PCIe adapter(s), and reinstall the I/O module. Repeat this procedure for the other I/O module.
2. Supported PCIe adapters that contain small form-factor pluggable (SFP) modules take up the length of an entire PCIe slot. To more easily remove or install these longer adapters, first remove the SFP modules as noted in the following procedures.

**To remove a PCIe adapter****Notices:**

1. When handling PCIe adapters, hold them securely by their edges. Do not touch their electronic elements.
2. Always store a PCIe adapter in its static-protective envelope if it is not installed in the system.

1. [Remove the I/O module.](#)
2. Disengage the metal cage by pushing the buttons on each side of the I/O module, and then flip the metal cage open. See [Figure 5-15](#).

**Figure 5-15: Opening Metal Cage**

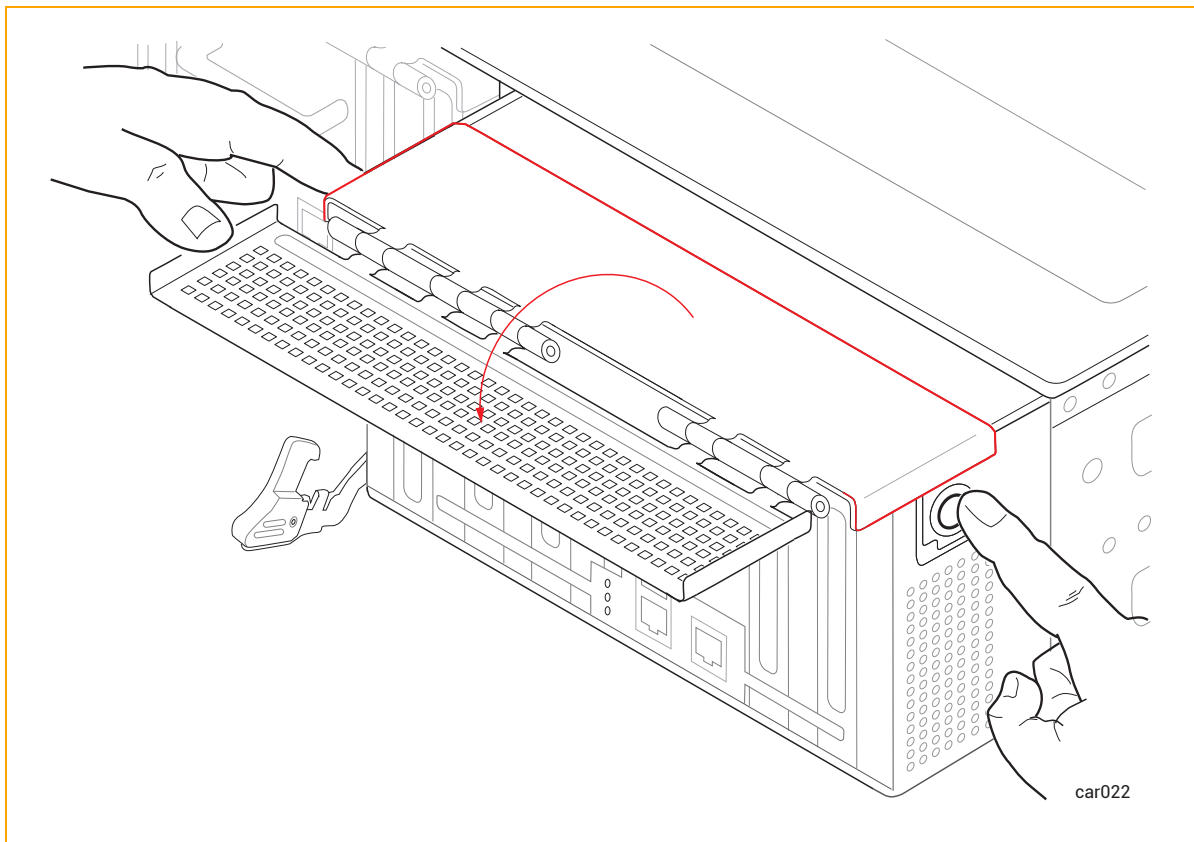

3. If your PCIe adapter contains SFP modules, remove them and go to the next step.  
Otherwise, go to the next step.
4. Pull the PCIe adapter out of its connector. See [Figure 5-16](#).

Figure 5-16: Removing PCIe Adapter

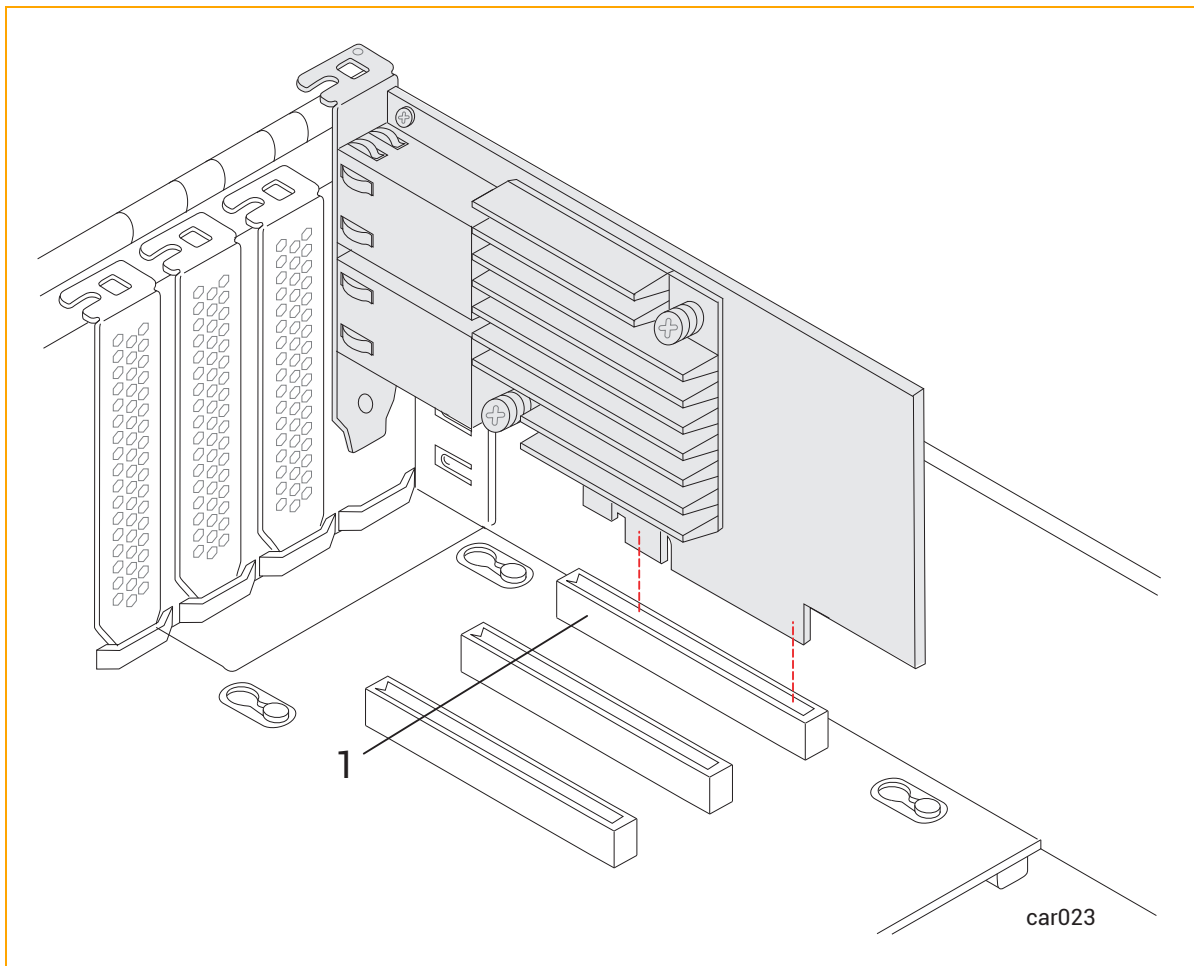

1 Connector

5. If the adapter does not disconnect easily, use a firm side-to-side tugging motion while maintaining steady pressure on the adapter.

**To install a PCIe adapter**

 **Note:** You should be familiar with the important information provided in "PCIe Adapters" on page 30 before you install a PCIe adapter.

 **Notice:** Before you begin this procedure, move the I/O module so that its front overhangs the surface on which it is resting by approximately two inches. Otherwise, the PCIe adapter cannot be installed correctly.

1. If the PCIe adapter contains SFP modules, remove them and go to the next step.  
Otherwise, go to the next step.
2. Install the PCIe adapter firmly into its connector. To do so, apply pressure to the part of the PCIe adapter located above the far side of the board connector (see arrow in [Figure 5-17](#)). Once installed, make sure that the PCIe adapter's top bracket is flush with the chassis.

**Figure 5-17: Installing PCIe Adapter**

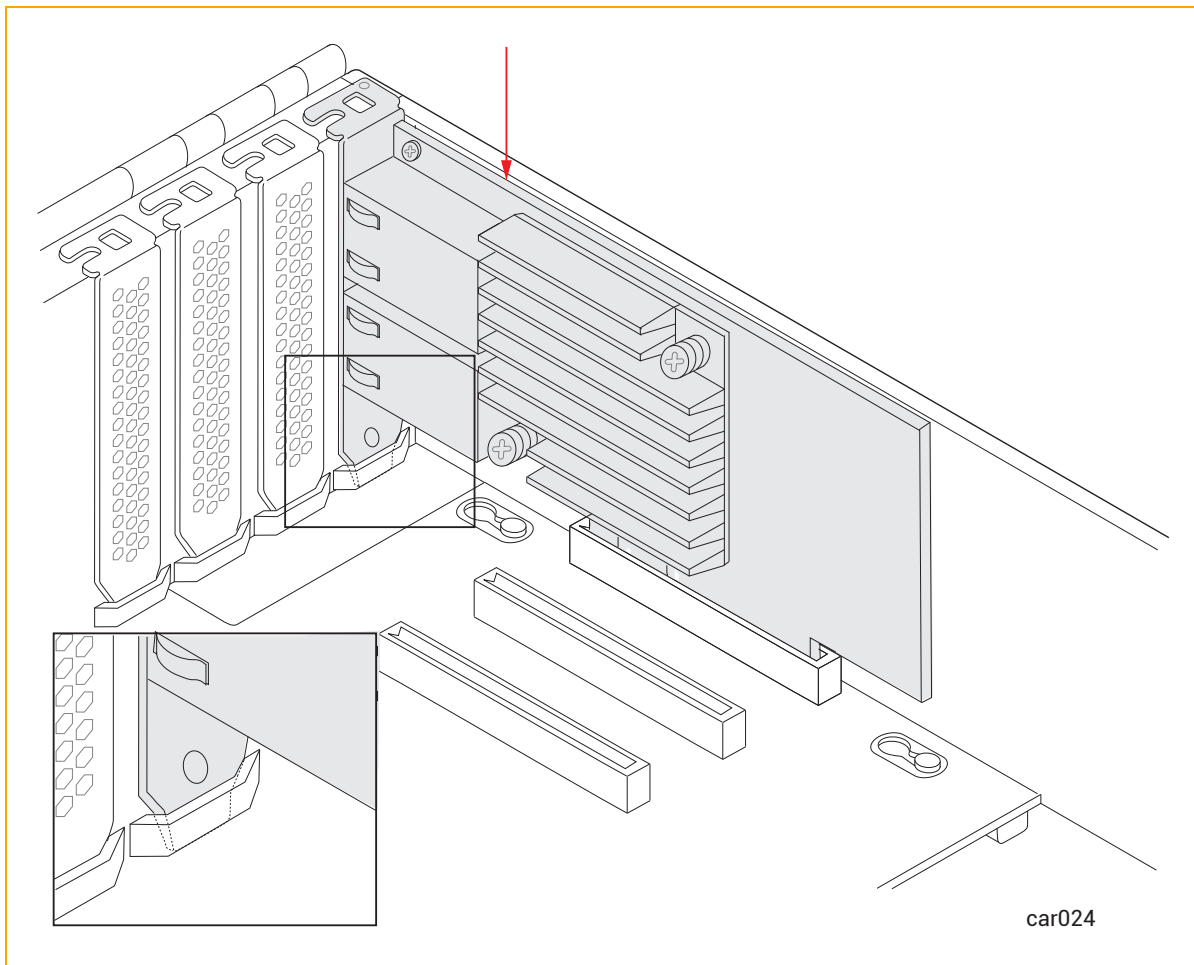

**Notice:** If the PCIe adapter is not seated correctly, the metal cage cannot close properly. This may lead to the I/O module becoming lodged in the chassis.

3. If you removed SFP modules earlier, reinsert them in the PCIe adapter and go to the next step.  
Otherwise, go to the next step.
4. Flip the metal cage closed until it clicks. See [Figure 5-18](#).

Figure 5-18: Closing Metal Cage

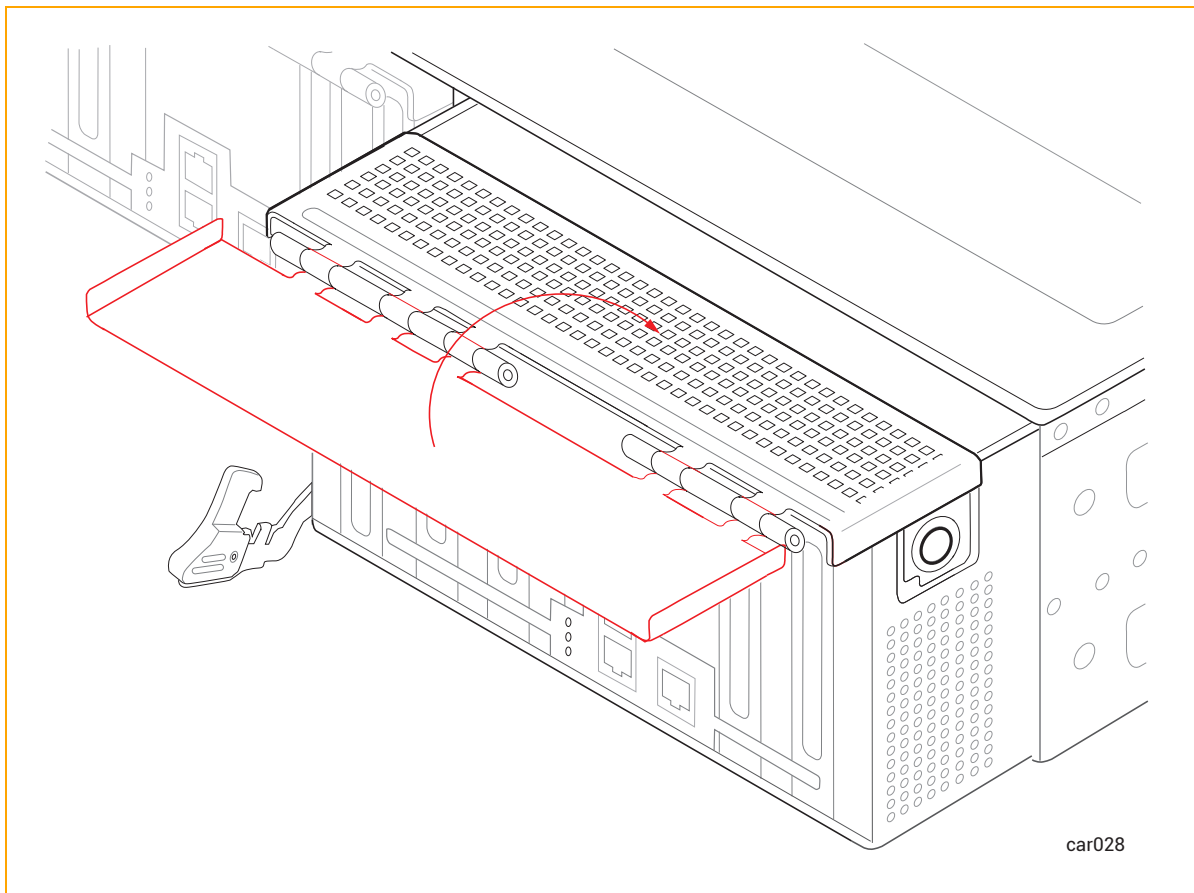

5. [Replace the I/O module.](#)

#### Related Topics

- "PCIe Adapters" on page 30
- "I/O Module" on page 29

#### Removing and Replacing a PSU and Power Cords

##### Cautions:



1. Use [ESD precautions](#) when performing these procedures.
2. Read "Replacing System Components" on page 100 before you remove any system components.

**Précautions:**



1. Utilisez les précautions ESD lors de l'exécution de ces procédures.
2. Lisez "[Replacing System Components](#)" on page 100 avant de retirer des composants du système.

## To remove a PSU

1. Unwrap the power-cord retention strap, and then disconnect the power cord. See [Figure 5-19](#).

**Figure 5-19: Disconnecting Power Cord and Retention Strap**

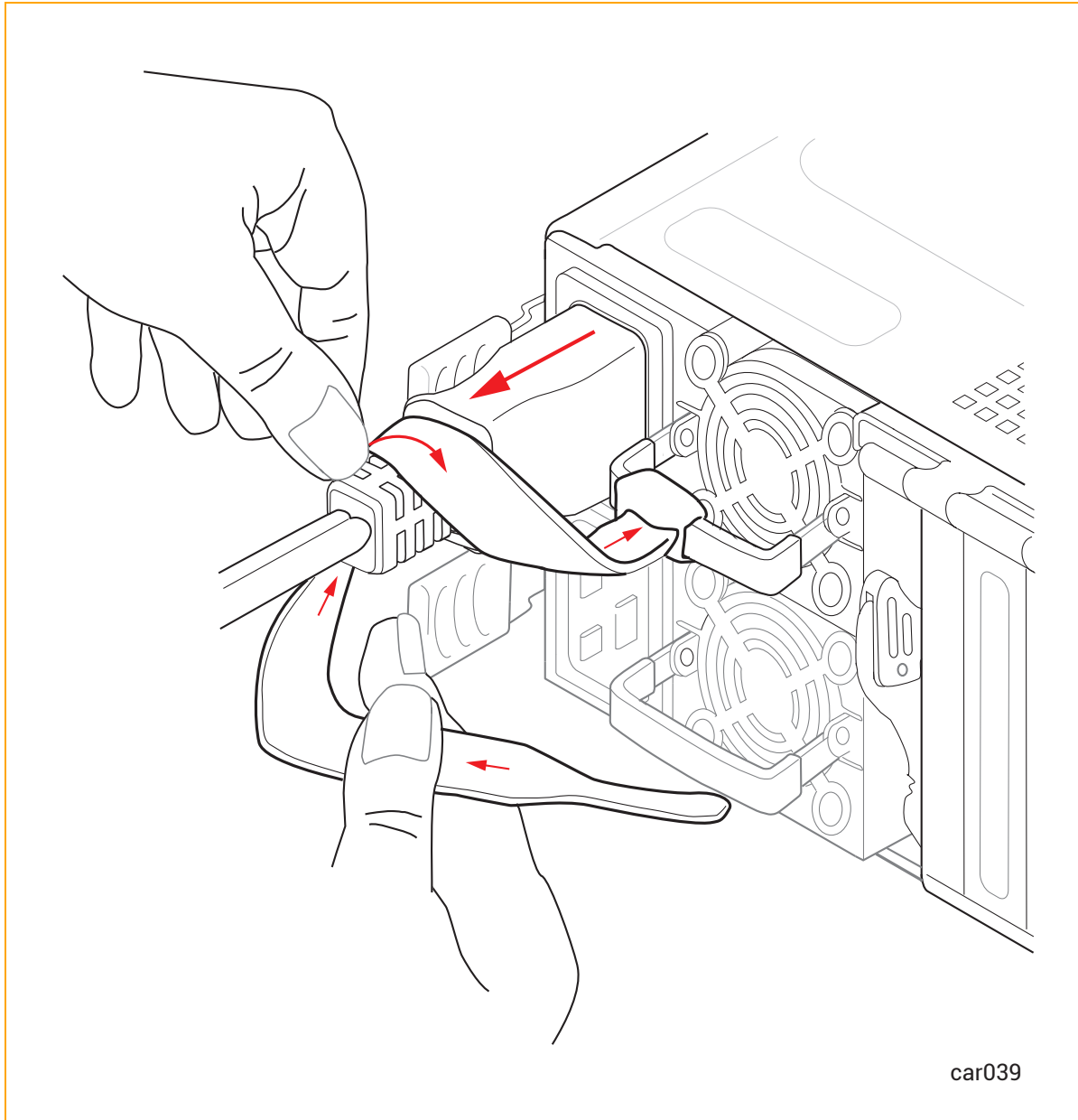

2. Push the release lever to the right while pulling the handle until the PSU releases. See [Figure 5-20](#).

Figure 5-20: Pushing PSU Release Lever

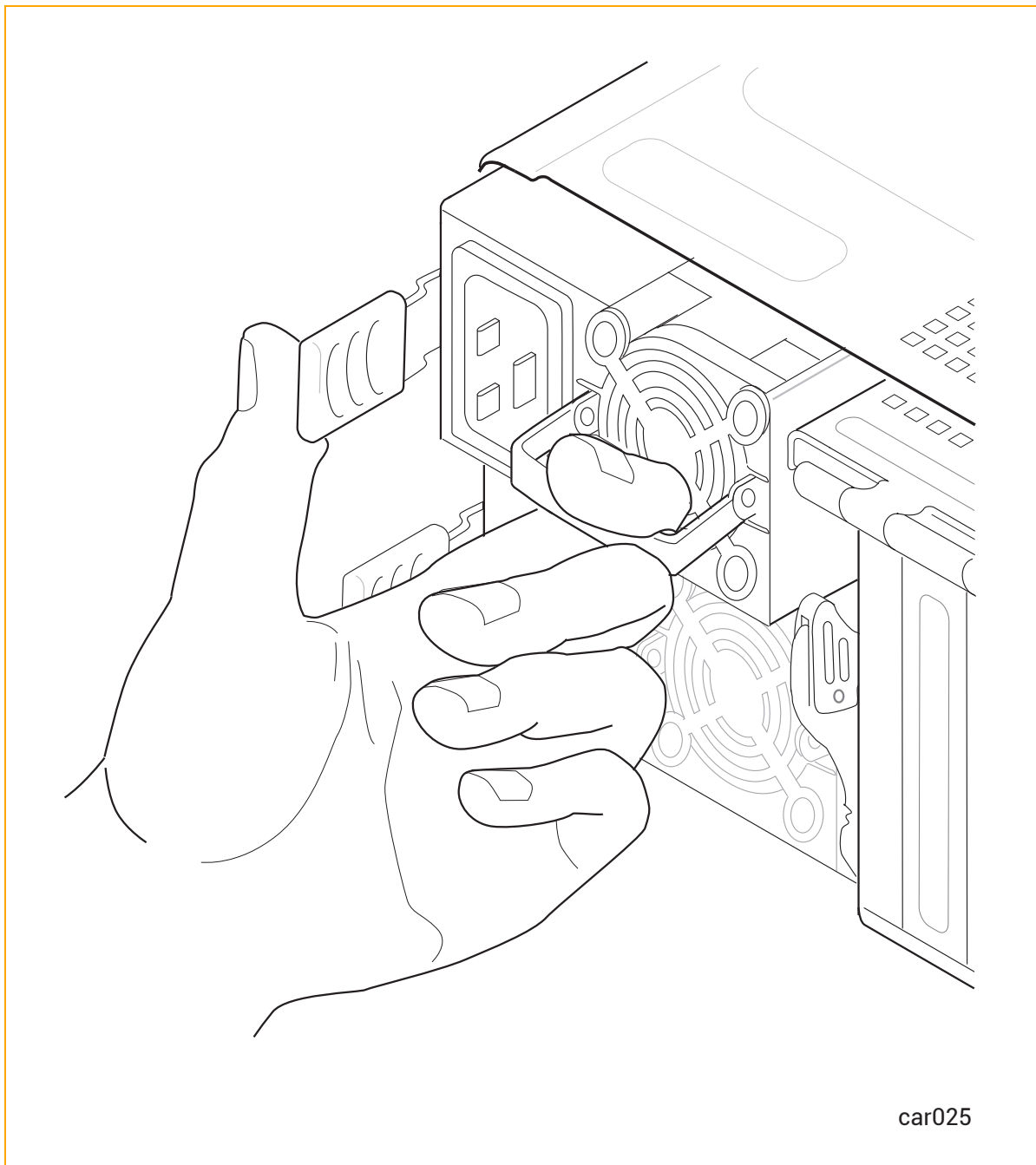

3. Release the release lever and pull the PSU out of the system chassis.

### To replace a PSU



**Caution:** When you insert a PSU into the system chassis, make sure that the plug is on the left and the fan is on the right, as shown in [Figure 5-19](#). Otherwise, damage may result.



**Précaution:** Lorsque vous insérez un bloc d'alimentation dans le châssis du système, assurez-vous que la fiche est à gauche et que le ventilateur est à droite, comme indiqué sur [Figure 5-19](#). Sinon, des dommages pourraient en résulter.

1. Slide the PSU into the system chassis until it stops.
2. If necessary, push the release lever to the right and gently push the PSU in until it is fully seated and the release lever latches.
3. Connect the power cord, and perform the steps in "[To fasten the power-cord retention strap](#)" on [page 74](#).

### To replace both power cords

1. Power off the system as described in "[Shutting Down the System](#)" on [page 83](#).
2. Disconnect all communications cables from the system.
3. Unwrap the power-cord retention straps, and then disconnect the power cords from the PSUs and the power sources.
4. Wait for all LEDs in the [front](#) and [rear](#) of the system to turn off, including the LEDs on both PSUs. All LEDs turning off indicates that the standby voltages have dissipated.
5. Replace the two power cords, using the correct power cords for the voltage being used, and [fasten the power-cord retention straps](#).
6. Reconnect all communications cables to the system.



# 6

## Chapter 6: Electrical Circuit and Wiring Information

For electrical circuit and wiring information that you need to provide to the contractor and/or facilities personnel responsible for wiring the power at the system installation site, see:

- ["Fault Protection Requirements" on page 133](#)
- ["Grounding Considerations" on page 133](#)
- ["Circuit Wiring Diagrams" on page 134](#)
- ["Electrical Power Connectors" on page 140](#)

### Fault Protection Requirements

Each CRU module in a ztC Endurance system contains internal fault/overload current protection. However, the system relies on the power distribution system at your site for protection against potential faults in the power cords and the wiring in the PSU AC inlet.

Power cords for a ztC Endurance system and PDU must not be connected to a branch circuit greater than 20A.

### Related Topics

- ["Electrical Circuit and Wiring Information" on page 133](#)

### Grounding Considerations

The system obtains an earth reference ground through the power cords attached to the system. Similarly, each peripheral device connected to the system obtains ground through its power cord. You **must** ensure that a high-integrity safety-ground conductor is installed as part of the wiring system (in accordance with U.S. national electric code NFPA 70 or the equivalent). The international safety standard (EN62368) for audio/video, information, and communication technology equipment also requires a ground conductor, but calls it a protective earth (PE) ground.

Depending on local conditions, ground potentials may differ between the system base and any peripheral devices connected to the system base. All grounds in the system **must** return to the same reference point in the power distribution system, as close as possible to **zero (0) volt potential** relative to earth reference ground. Earth reference ground is typically a metal stake in the ground to which the ground conductors from one or more buildings are attached.

As shown in [Figure 6-1](#), a *star ground* is often used to obtain the same earth reference ground. Each earth reference ground, such as the system base ground, is returned separately to a common point where a zero-volt (0V) earth ground exists. The star ground ensures that all equipment is at the same potential and that no noise or safety problems associated with an unpredictable or uncharacterized grounding system will occur.

**Figure 6-1: Star Ground Example**

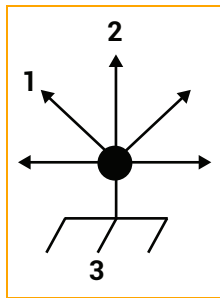

1	To monitor
2	To ztC Endurance system
3	Earth reference ground (0V)

### Related Topics

- ["Electrical Circuit and Wiring Information" on page 133](#)

### Circuit Wiring Diagrams

The circuit wiring diagrams shown in this topic illustrate how the hot, ground, and/or neutral AC signals should be connected to the power input plugs of the ztC Endurance system and other components.

In the following diagrams, the power inputs for ztC Endurance systems are labeled X and Y, as shown in [Figure 6-2](#) and [Figure 6-3](#), to eliminate any ambiguities in the nomenclature. For single-phase applications, the X input is connected to the L (Line) hot input, and the Y input is connected to the N (Neutral) input. However, for split-phase or three-phase applications, the X and Y inputs are connected to L1, L2, or L3 (separate lines). Therefore, for split-phase or three-phase applications, both X and Y can be electrically hot with respect to the system base (earth reference ground).

Figure 6-2 shows a face view of the physical locations of the X and Y inputs on a customer-supplied PDU (either A or B).

Figure 6-2: PDU Power Input Labeling

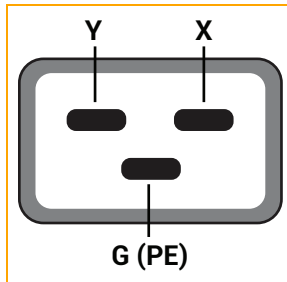

Figure 6-3 shows a face view of the physical locations of the X and Y inputs on a ztC Endurance system's PSU (either A or B).

Figure 6-3: ztC Endurance Enclosure Power Input Labeling

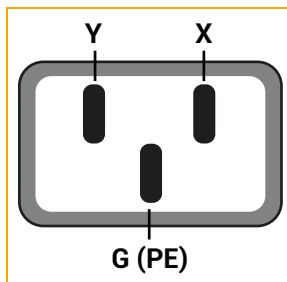

Figure 6-4 shows a single-phase 120V AC circuit connection. Note that this application requires a single-pole circuit breaker.

Figure 6-4: Single-Phase 120V AC Circuit Connection

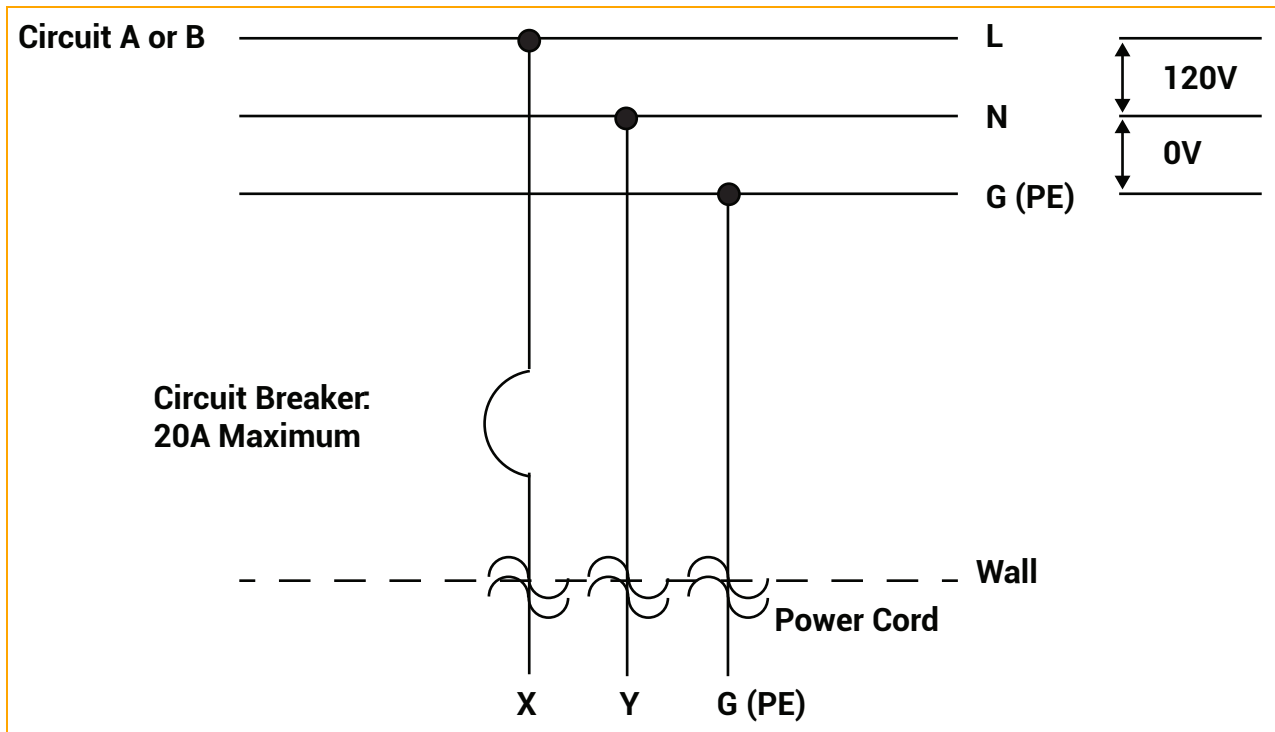

Figure 6-5 shows a single-phase 240V AC circuit connection. Note that this application requires a single-pole circuit breaker.

Figure 6-5: Single-Phase 240V AC Circuit Connection

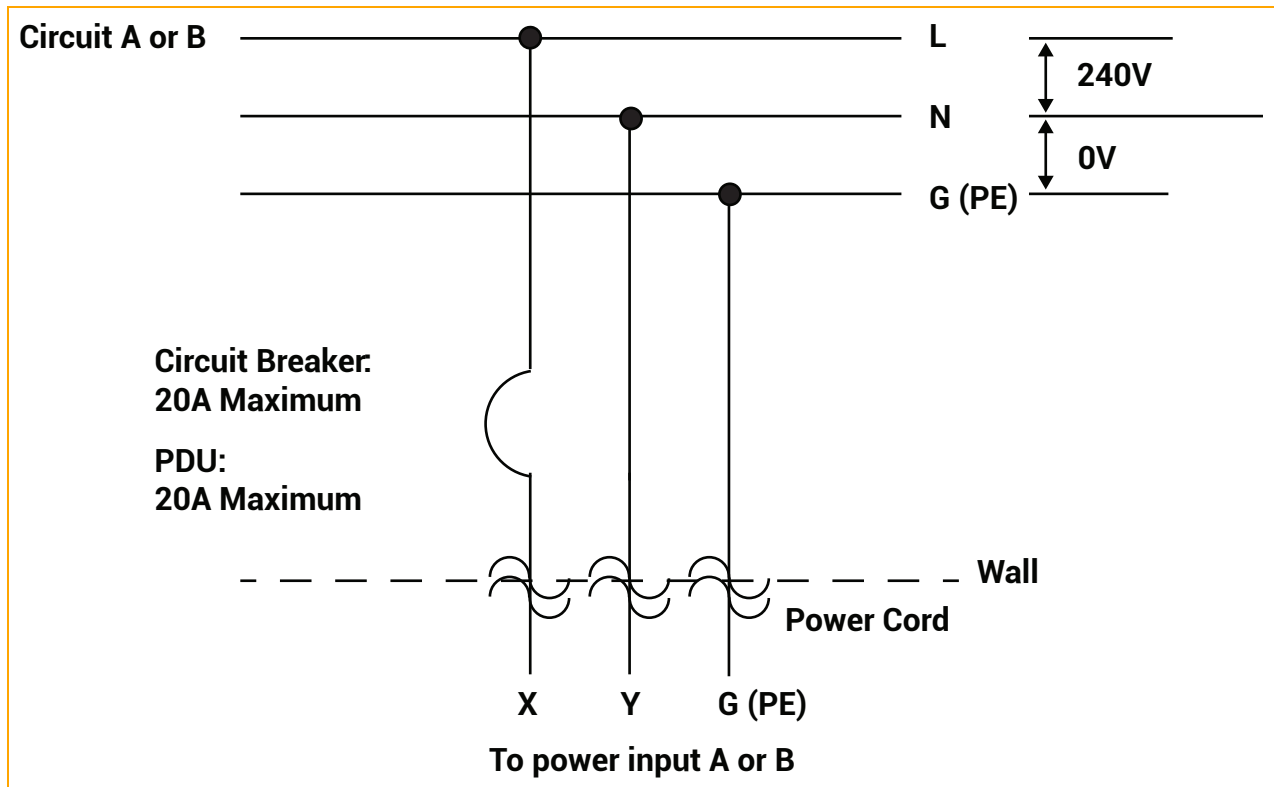

Figure 6-6 shows a split-phase 120/240V AC circuit connection. Note that this application requires a double-pole circuit breaker.

Figure 6-6: Split-Phase 120/240 Volts AC Circuit Connection

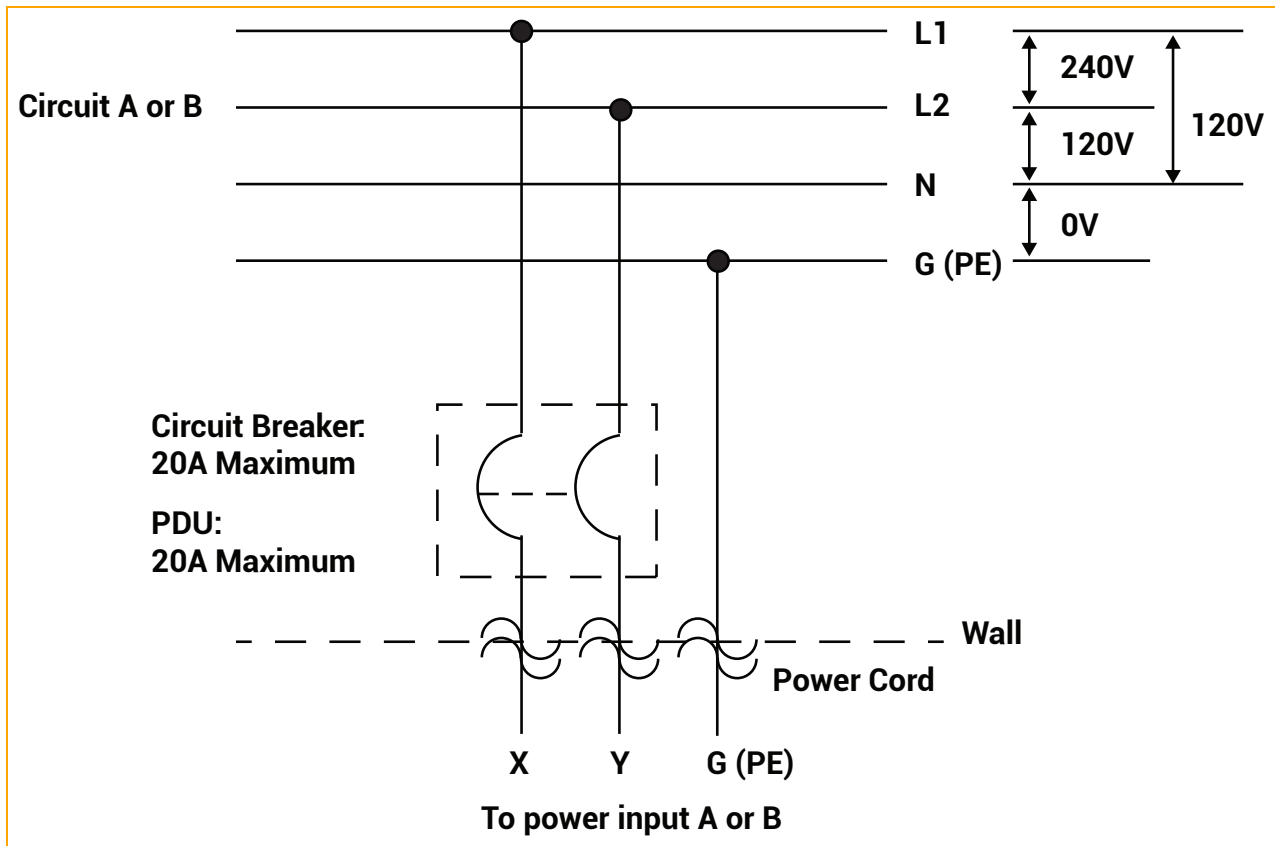

Figure 6-7 shows a three-phase 208V AC, Y-, or  $\Delta$ -source circuit connection, which is a phase-to-phase source connection. Note that the X and Y inputs on the ztC Endurance system can be connected from L1 and L2, L2 and L3, or L1 and L3. This application requires a double-pole circuit breaker.

Figure 6-7: Three-Phase 208V AC, Y-, or  $\Delta$ -Source Circuit Connection, Phase-to-Phase

Figure 6-8 shows a three-phase 380V AC, Y-, or  $\Delta$ -source circuit connection, which is a phase-to-neutral source connection. Note that the ztC Endurance system's X input can be connected to L1, L2, or L3. This application requires a single-pole circuit breaker.

Figure 6-8: Three-Phase 380V AC, Y-, or Δ-Source Circuit Connection, Phase-to-Neutral

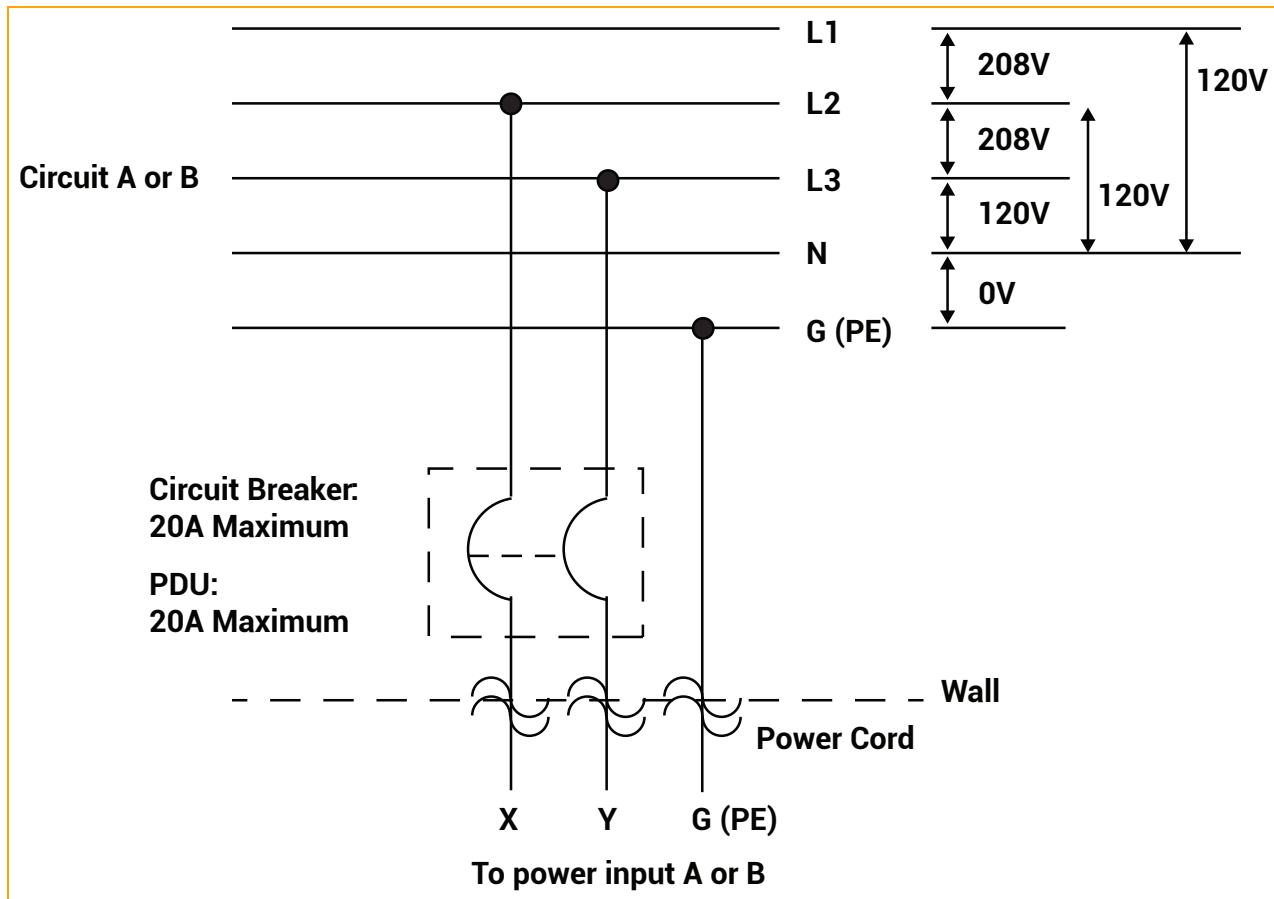
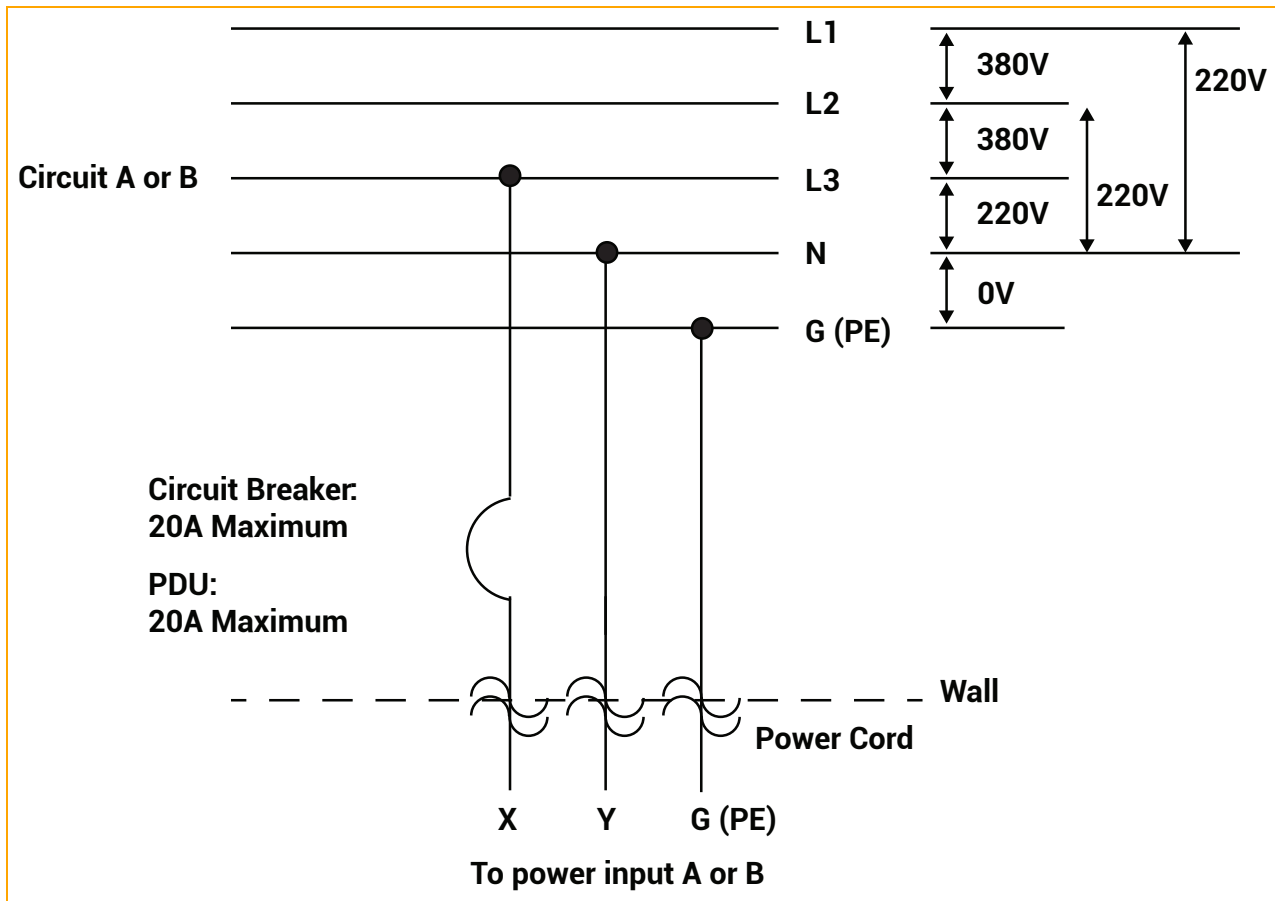

### Related Topics

- ["Electrical Circuit and Wiring Information" on page 133](#)

### Electrical Power Connectors

Table 6-1 describes the connectors (that is, the receptacles) required by the AC power cords that Penguin Solutions supplies with ztC Endurance systems and optional devices.

**Table 6-1: Connectors for AC Power Outlets**

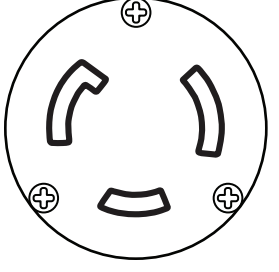
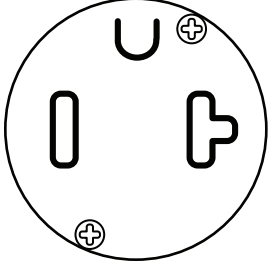
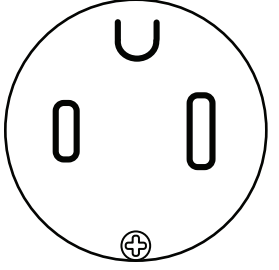
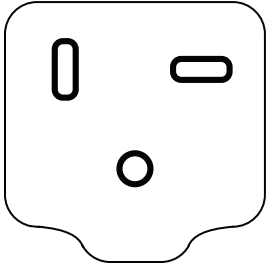
Connector	Configuration	Rating	Description
NEMA L6-20		20A, 250 volts AC	2-pole, 3-wire
NEMA 5-20		20A, 125 volts AC	2-pole, 3-wire
JIS C 8303		15A, 125 volts AC	2-pole, 3-wire
JIS C 8303		15A, 250 volts AC	2-pole, 3-wire

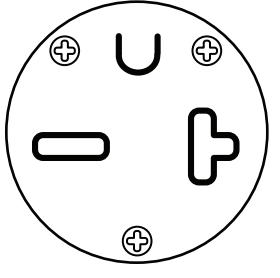
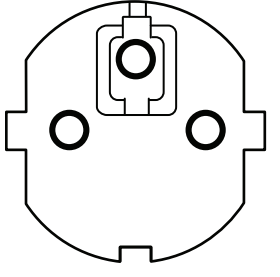
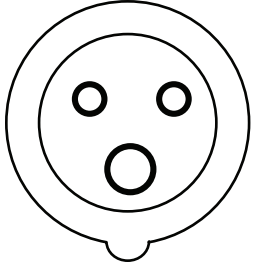
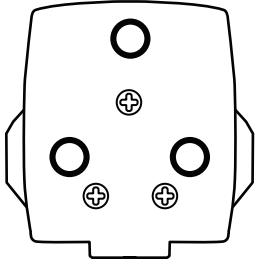
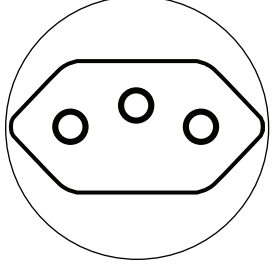
Connector	Configuration	Rating	Description
NEMA 6-20 / CNS 690		20A, 250 volts AC	2-pole, 3-wire
CEE (7) VII		16A, 250 volts AC	2-pole, 3-wire
IEC 60309 (formerly IEC 309)		16-20A, 250 volts AC	2-pole, 3-wire
SABS 164-1:1992 / IS 1293 IND 16		16A, 250 volts AC	2-pole, 3-wire
NBR 14136 (Brazil)		10A, 250 volts AC	2-pole, 3-wire

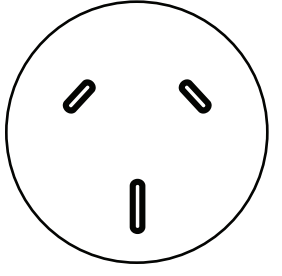
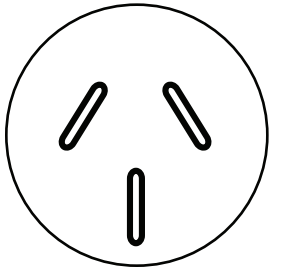
Connector	Configuration	Rating	Description
SAA/3/15 AS/NZS 3112-1993		15A, 250 volts AC	2-pole, 3-wire
GB1002-1996		10A, 250 volts AC	2-pole, 3-wire

**Related Topics**

- ["Electrical Circuit and Wiring Information" on page 133](#)



## Part 2: ztC Endurance Software Guide

The ztC Endurance Software Guide discusses the following topics:

- ["System Software Installation \(Windows\)" on page 147](#)
- ["System Software Administration \(Windows\)" on page 191](#)
- ["Using the ztC Endurance Console" on page 235](#)
- ["Overview of the BMC Web Console" on page 271](#)

### Related Topics

- ["ztC Endurance Hardware Guide" on page 15](#)
- ["ztC Endurance Supporting Documents" on page 277](#)



# 7

## Chapter 7: System Software Installation (Windows)

To install the system software, see ["Installing the System Software" on page 147](#).

### Installing the System Software

Before you install the system software, you must perform some tasks to prepare for the installation. One of the tasks you will perform is to determine if Penguin Solutions preinstalled the system software (that is, Automated Uptime Layer with Smart Exchange and Windows Server) at the factory. This information determines which type of system software installation you perform:

- If Penguin Solutions preinstalled the system software at the factory, you perform a *factory-installed system software installation*.
- If Penguin Solutions did not preinstall the system software at the factory, you perform a *full system software installation*. This installation procedure installs Automated Uptime Layer with Smart Exchange and Windows Server, and allows you to enter customized configuration settings for your ztC Endurance system.



**Note:** On all ztC Endurance systems, the Standby OS (Ubuntu, a Linux distribution) is preinstalled at the factory in an internal NVMe drive inside each compute module. In general, you need to access the Standby OS only for system software installation or troubleshooting purposes.

For both types of installations, you power on the system to boot the preinstalled Standby OS on both compute modules, and you later run configuration scripts to enter different settings that are required to support the software installation.

After the software installation completes, you need to perform some post-installation tasks, as described in ["Post-Installation Tasks" on page 184](#).

## Next Steps

Prepare for the system software installation as described in ["Preparing to Install the System Software" on page 148](#).

### Preparing to Install the System Software

Perform the following steps before you install the system software:

"I. Review the Preinstallation Checklist" on page 148

"II. Determine Which Software Installation Procedure to Perform" on page 159

#### I. Review the Preinstallation Checklist

Review the following checklist before you install the system software.



**Caution:** Make sure that the network switch used during the system software installation is 1 Gb or faster. Otherwise, the copy of the system software ISO to the host system may time out, resulting in a failed installation.

#### Preinstallation Checklist

- Gather and record the site-specific settings described in ["Gathering Information" on page 148](#). The installation and configuration scripts require this information.

#### Gathering Information

Review the information in [Table 7-1](#) and [Table 7-2](#), and then print the ["Password and Installation Settings Printable Worksheet" on page 161](#). Use it to record your passwords and installation settings.



**Notice:** Keep your recorded passwords and installation settings in a secure place so that you can access your ztC Endurance system after installation. Keeping this information accessible also helps your authorized Penguin Solutions service representative to access the system in the event of a service call.

[Table 7-1](#) describes the user-configurable passwords required for the software installation. You are prompted for these values only on the command line.

**Table 7-1: Password Settings**

Password Type	Description
<b>System Passwords</b>	
BMC Web console admin password	<p>Password for the BMC Web console admin user account.</p> <p>You need to set a password for the BMC Web console to support the software installation and troubleshooting, but you can also use the BMC Web console to remotely monitor and administer the system as summarized in <a href="#">"Configuring the BMCs for Remote System Management"</a> on page 187.</p> <p>The password, which is case-sensitive, must be a string of 8 to 16 alphanumeric characters and must start with an alphabetical character. The special characters - (hyphen), _ (underscore), and @ (at-sign) are allowed.</p> <p><b>Note:</b> Do not use the special characters #, !, or \$ in the BMC Web console admin password.</p>
Management zenadmin password	<p>Password for the zenadmin user account of the ztC Endurance Standby operating system (OS).</p> <p>You log in to the Standby OS to install the system software, as described in <a href="#">"Performing a Full System Software Installation"</a> on page 167. Specifying a new password for the zenadmin account during the software installation replaces the default password (zenadmin).</p> <p>The password, which is case-sensitive, must be a string of 6 to 20 alphanumeric characters. It cannot be the same as the username. The following special characters are allowed: - (hyphen), _ (underscore), @ (at-sign), % (percent sign), &amp; (ampersand), # (pound sign), \ (backslash), . (period), \$ (dollar sign), * (asterisk), ! (exclamation point).</p>
Windows Administrator password	<p>Password for the Administrator account of the Windows host.</p>

Password Type	Description
	<p>The password, which is case-sensitive, must be a string of 8 to 24 alphanumeric characters and must contain a lowercase alphabetical character, a numeric character, and a special character. It cannot be the same as the username. The following special characters are allowed: - (hyphen), _ (underscore), @ (at-sign), % (percent sign), &amp; (ampersand), # (pound sign), \ (backslash), . (period), * (asterisk), ! (exclamation point).</p>

Table 7-2 describes the system and network settings needed for the software installation. The type of system software installation you are performing determines how you supply the settings:

- **Command-line prompts.** If Penguin Solutions installed the system software at the factory, you must supply the settings on the command line. If you are performing a full system software installation, you can optionally supply the settings on the command line.
- **Configuration-file entries.** If Penguin Solutions did not install the system software at the factory, you can optionally supply the settings in an installation configuration file (`zen_config.yaml`). Using a installation configuration file saves you time, as you can reuse the file to run other configuration scripts. If Penguin Solutions installed the system at the factory, you cannot use the installation configuration file to supply the settings.

Most settings in Table 7-2 show two **Setting** names:

- Longer setting names in mixed case (for example, **BMCA hostname**) are similar to the command-line prompts in the installation script.
- Shorter setting names in all lowercase letters (for example, **bmca\_hostname**) match the names in the installation configuration file. Table 7-2 may not reflect the exact order in which you are asked to supply the settings in the file.

**Note:**

A ztC Endurance system requires a total of 11 IP addresses for the following interfaces in order to provide and configure full redundancy:



- Ten interfaces on the management network:
  - One for each BMC port (four total)
  - One for each embedded **1G MGMT** port for use by each Standby OS (four total)
  - One for each embedded **1G MGMT** port for use by the Windows OS (two total)
- One interface on the production network, for the teamed interface of embedded **10G PORT2** ports in each I/O module

You can configure each interface type to use either the static or DHCP protocol. Also, you can configure additional interfaces after the installation process is complete.



**Table 7-2: Installation Settings**

Setting	Description
<b>System Information Variables</b>	
system_id	<p><b>Note: Applies only if you are preparing an installation configuration file.</b></p> <p>The system ID to include in host name construction. For example, if the fully qualified domain name (FQDN) of a system is ocean . abc . com, where ocean is the host name and the DNS domain name is abc . com, the system_id is ocean.</p> <p>This setting is helpful if you are creating installation configuration files for many systems, so you can enter the ID only once at the top of the configuration file, and replace it with the \$SYSTEM_ID variable wherever necessary.</p>
system_domain	<p><b>Note: Applies only if you are preparing an installation</b></p>

Setting	Description
	<p><b>configuration file.</b></p> <p>The system domain to include in host name construction. For example, if the fully qualified domain name of a system is ocean . abc . com, where ocean is the host name and the DNS domain name is abc . com, the system domain is abc . com.</p> <p>This setting is helpful if you are creating installation configuration files for many systems, so you can enter the domain only once at the top of the configuration file, and replace it with the \$SYSTEM-DOMAIN variable wherever necessary.</p>
<p>system_ nameserver</p>	<p><b>Note: Applies only if you are preparing an installation configuration file.</b></p> <p>The system name server to use in name server fields in the installation configuration file. Specify an IP address for this variable, or specify --NONE--.</p> <p>This setting is helpful if you are creating installation configuration files for many systems, so you can enter the name server only once at the top of the configuration file, and replace it with the \$NAMESERVER variable wherever necessary.</p>
<p><b>BMC Settings</b></p>	
<p>BMCA hostname bmca_hostname</p>	<p>BMC A host name, where BMC A is the BMC in compute module A. You can specify either the host name or the fully qualified domain name) (FQDN).</p> <p>You connect to this host name or the IP address of BMC A to remotely monitor and manage compute module A with the BMC Web console. For more information, see <a href="#">"Configuring the BMCs for Remote System Management" on page 187.</a></p>

Setting	Description
BMC B hostname bmc_b_hostname	BMC B host name, where BMC B is the BMC in compute module B. You can specify either the host name or the FQDN.  You connect to this host name or the IP address of BMC B to remotely monitor and manage compute module B with the BMC Web console. For more information, see <a href="#">"Configuring the BMCs for Remote System Management" on page 187.</a>
BMC network protocol bmc_netproto	BMC IP protocol (dhcp or static).
BMC A eth 0 bmca_eth0	BMC A eth 0 IPv4 or IPv6 address (IP address/prefix) or leave blank (for DHCP).
BMC A eth 1 bmca_eth1	BMC A eth 1 IPv4 or IPv6 address (IP address/prefix) or leave blank (for DHCP).
BMC B eth 0 bmc_b_eth0	BMC B eth 0 IPv4 or IPv6 address (IP address/prefix) or leave blank (for DHCP).
BMC B eth 1 bmc_b_eth1	BMC B eth 1 IPv4 or IPv6 address (IP address/prefix) or leave blank (for DHCP).
<b>Standby OS Settings</b>	
Standby CMA hostname standbya_hostname	Standby A host name, where Standby A is the Standby OS running on compute module A. You can specify either the host name or the FQDN.
Standby CMB	Standby B host name, where Standby B is the Standby OS

Setting	Description
hostname standbyb_ hostname	running on compute module B. You can specify either the host name or the FQDN.
Standby network protocol standby_netproto	Standby IP protocol (dhcp or static).
Standby CMA IP Address 1 standbya_ipaddr_ 1	Standby A IPv4 or IPv6 address (IP address/prefix) or leave blank (for DHCP) for A eno1.
Standby CMA IP Address 2 standbya_ipaddr_ 2	Standby A IPv4 or IPv6 address (IP address/prefix) or leave blank (for DHCP) for A eno2.
Standby CMB IP Address 1 standbyb_ipaddr_ 1	Standby B IPv4 or IPv6 address (IP address/prefix) or leave blank (for DHCP) for B eno1.
Standby CMB IP Address 2 standbyb_ipaddr_ 2	Standby B IPv4 or IPv6 address (IP address/prefix) or leave blank (for DHCP) for B eno2.
Standby Nameserver standby_ nameserver	Standby IPv4/IPv6 name server address or leave blank (for DHCP).  <b>Note for installation configuration file users:</b> If you do not want to use a name server and do not want to be prompted for one during the installation, specify --NONE--.

Setting	Description
<b>Windows Settings</b>	
Windows hostname win_hostname	<p>Name of the Windows host. You can specify either the host name or the FQDN.</p> <p>You connect to this host name or the IP address of your Windows host to configure and manage your system.</p> <div data-bbox="581 642 1294 810" style="border: 1px solid #c08040; padding: 5px;">  <p><b>Notice:</b> Do not specify the string "OS" or "Name" as part of the Windows hostname during installation.</p> </div>
Windows network protocol win_bootproto	<p>Windows host IP protocol (dhcp or static).</p>
Windows IP address win_ipaddr	<p>Windows host IP address.</p> <div data-bbox="581 1083 1294 1377" style="border: 1px solid #c08040; padding: 5px;">  <p><b>Notice:</b> You cannot set this value to an IPv6 address during installation. If you want your system to support IPv6 addresses after installation, run the <code>net_config.sh</code> script as described in <a href="#">"Updating Network IP Configuration Settings"</a> on page 222.</p> </div>
Windows Gateway win_gateway	<p>Windows host IPv4/IPv6 gateway address or leave blank (for DHCP).</p> <div data-bbox="581 1518 1294 1812" style="border: 1px solid #c08040; padding: 5px;">  <p><b>Notice:</b> You cannot set this value to an IPv6 gateway address during installation. If you want your system to support IPv6 gateways after installation, run the <code>net_config.sh</code> script as described in <a href="#">"Updating Network IP Configuration Settings"</a> on page 222.</p> </div>

Setting	Description
Windows Netmask win_netmask	Windows host IPv4 subnet address or leave blank (for DHCP/IPv6 or if prefix is supplied in IP address).
Windows IPv6 Prefix win_ipv6_prefix	Windows host IPv6 prefix or leave blank (for DHCP). Value must be an integer less than or equal to 128.  <div style="border: 1px solid #ccc; padding: 10px; margin: 10px 0;">  <p><b>Notice:</b> This value cannot be set during installation. If you want your system to support IPv6 addresses after installation, run the <code>net_config.sh</code> script as described in "Updating Network IP Configuration Settings" on page 222.</p> </div>
Windows Nameserver win_nameserver	Windows host IPv4/IPv6 name server address or leave blank.  <b>Note for installation configuration file users:</b> If you do not want to use a name server and do not want to be prompted for one during the installation, specify <code>--NONE--</code> .
Path/URL to the Windows ISO win_iso	Windows ISO path or URL. For example, if you copy the ISO into the Standby OS as described later in "To transfer the Windows ISO image to the ztC Endurance system with a USB storage device" on page 174, the location would be similar to:  <code>/path/en-us_windows_server_2022_updated_nov_2024_x64_dvd_4e34897c.iso</code>
Windows Type win_osname	Windows operating-system type (datacenter or standard). <b>This value is case-sensitive.</b>
<b>Windows Management Network Settings</b> (Used by ztC Endurance console)	

Setting	Description
Windows management network protocol win_mgmt_netproto	Windows management IP protocol (dhcp or static).
Windows management IP address 1 win_mgmt_ipaddr1	Windows management network IPv4 subnet address or leave blank (for DHCP/IPv6 or if prefix is supplied in IP address).
Windows management IP address 2 win_mgmt_ipaddr2	Windows management network IPv4 subnet address or leave blank (for DHCP/IPv6 or if prefix is supplied in IP address).
<b>ztC Endurance Management Network Settings</b> (Used by BMC and Standby OS)	
Mgmt Gateway zenmgmt_gateway	Management network IPv4/IPv6 gateway address or leave blank (for DHCP).
Mgmt Netmask zenmgmt_netmask	Management network IPv4 subnet address or leave blank (for DHCP/IPv6 or if prefix is supplied in IP address).
Mgmt IPv6 Prefix zenmgmt_ipv6_prefix	Management network IPv6 prefix or leave blank (for DHCP/IPv6 or if prefix is supplied in IP address).

Setting	Description
<b>Support Notifications over the ActiveService Network (ASN) Settings</b>	
Enable Support Notifications asn_enabled	Indicates whether or not to enable Support Notifications over the ASN (yes or no).  Activating the Support Notifications allows the ztC Endurance system to send health and status notifications to Penguin Solutions Customer Service over a secure Internet connection. To access related settings in ztC Endurance console after installation, see " <a href="#">Configuring Remote Support Settings</a> " on page 267.
Asset ID asn_asset_id	Asset Identifier (ID), in the format zennnnn. This value is required even if you do not enable Support Notifications.  The asset ID is located on your sales order form and on top of the system chassis. For information about locating the asset ID sticker for your system on top of the system chassis, see " <a href="#">Installing the System in a Cabinet</a> " on page 60.

- Make sure you have a **Penguin Solutions Customer Service Portal** account. If you do not already have an account, register for one at <https://support.penguinsolutions.com/csm>.
- Check that you have the most current [Release Notes: Automated Uptime Layer with Smart Exchange Release WIN-2.0.0.0 \(Windows\)](#) and software installation topics for your distribution. To restore your installation, make sure you have the appropriate version of the release level that you will restore.
- Prepare to accept the end-user license agreements (EULAs) that are presented during the installation process. To locate and read the text of the EULAs you must accept before installing Automated Uptime Layer with Smart Exchange, see "[End-User License Agreements and Warranty](#)" on page 297. You should not perform the installation if you cannot accept the EULAs or are not authorized to accept them. The installation process terminates if you decline any EULAs.

- Consider whether you want to enable Support Notifications over the ASN. Activating Support Notifications over the ASN allows the ztC Endurance system to send health and status notifications to Penguin Solutions Customer Service over a secure Internet connection.

You are prompted to enable or disable Support Notifications over the ASN during the software installation.

- With the ztC Endurance system halted, detach most peripheral devices from the system (exceptions are noted below). Devices to detach include:
  - Unsupported PCIe adapters
  - External storage systems
  - USB devices, **except for** the keyboard, mouse, and USB storage device that you use to copy the Windows ISO during a full system software installation



**Notice:** The installation process cannot accommodate the presence of customer-added or unknown hardware. Add any such hardware, and configure the system to support it, only after completing the installation and verifying that the system functions as expected.

## II. Determine Which Software Installation Procedure to Perform

The software installation procedure you perform depends on whether your company opted to have Penguin Solutions install the system software at the factory.

If you do not know whether Penguin Solutions installed the system software at the factory, check the sales order. If you do not have the sales order, perform the following procedure.

### To determine which software installation procedure to perform

1. Turn on the monitor(s) and press the power button on the control-panel ear of the system (see [Figure 7-1](#) for the location of the power button).

Figure 7-1: Power Button

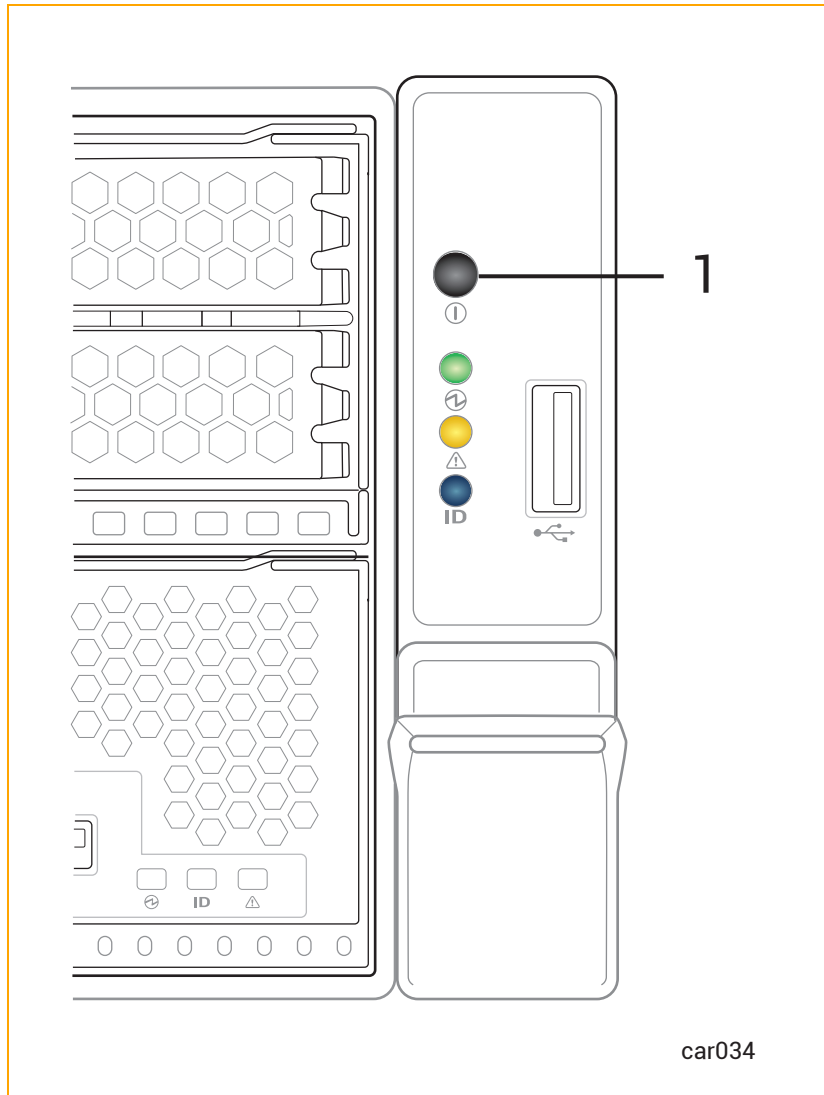

1 Power button

2. When the system boots, determine which of the following scenarios applies to your system:
  - **The system software was installed at the factory** if the system automatically boots the Standby OS on both modules, reboots the Windows OS on compute module A, and the **Hello there** window appears.

- **The system software was not installed at the factory** if the system automatically boots the Standby OS on both modules and then does nothing else.

3. Power down the system by briefly pressing the power button again.

## Next Steps

Perform the appropriate system software installation procedure:

- If Penguin Solutions installed the system software at the factory, see ["Starting a Factory-Installed System for the First Time" on page 164.](#)
- If Penguin Solutions did not install the system software at the factory, see ["Performing a Full System Software Installation" on page 167.](#)

## Password and Installation Settings Printable Worksheet

Print the following worksheet and use it to record your passwords and installation settings. Be sure to save this checklist in a secure and accessible location.

After printing this worksheet, return to ["Gathering Information" on page 148.](#)

**Table 7-3: Passwords and Installation Settings Worksheet**

Setting	Entry
<b>System Passwords</b>	
BMC Web console admin password	
Management zenadmin password	
Windows Administrator password	
<b>System Information Variables</b>	
system_id	
system_domain	
system_nameserver	
<b>BMC Settings</b>	

Setting	Entry
BMCA hostname / bmca_ hostname	
BMCB hostname / bmcb_ hostname	
BMC network protocol / bmc_ netproto	
BMC A eth 0 / bmca_eth0	
BMC A eth 1 / bmca_eth1	
BMC B eth 0 / bmcb_eth0	
BMC B eth 1 / bmcb_eth1	
<b>Standby OS Settings</b>	
Standby CMA hostname / standbya_hostname	
Standby CMB hostname / standbyb_hostname	
Standby network protocol / standby_netproto	
Standby CMA IP Address 1 / standbya_ipaddr_1	
Standby CMA IP Address 2 / standbya_ipaddr_2	
Standby CMB IP Address 1 / standbyb_ipaddr_1	
Standby CMB IP Address 2 / standbyb_ipaddr_2	
Standby Nameserver / standby_	

Setting	Entry
nameserver	
<b>Windows Settings</b>	
Windows hostname / win_ hostname	
Windows network protocol / win_ bootproto	
Windows IP address / win_ipaddr	
Windows Gateway / win_gateway	
Windows Netmask / win_netmask	
Windows IPv6 Prefix / win_ipv6_ prefix	
Windows Nameserver / win_ nameserver	
Path/URL to the Windows ISO / win_iso	
Windows Type / win_osname	
<b>Windows Management Network Settings (Used by ztC Endurance console)</b>	
Windows management network protocol / win_mgmt_netproto	
Windows management IP address 1 / win_mgmt_ipaddr1	
Windows management IP address 2 / win_mgmt_ipaddr2	
<b>ztC Endurance Management Network Settings (Used by BMC and Standby OS)</b>	
Mgmt Gateway / zenmgmt_	

Setting	Entry
gateway	
Mgmt Netmask / zenmgmt_netmask	
Mgmt IPv6 Prefix / zenmgmt_ipv6_prefix	
<b>Support Notifications over the ActiveService Network (ASN) Settings</b>	
Enable Support Notifications / asn_enabled	
Asset ID/ asn_asset_id	

### Starting a Factory-Installed System for the First Time

If Penguin Solutions installed the system software at the factory, perform the following procedure to start the ztC Endurance system for the first time.



**Notice:** Do not perform this procedure until you have performed all of the procedures described in "Preparing to Install the System Software" on page 148.

### To complete the installation

1. Turn on the monitor(s) and press the power button on the control-panel ear of the system.



**Note:** If you are using only one monitor and keyboard, make sure they are connected to compute module A.

2. As each compute module boots, perform the following steps on **both** compute modules:
  - a. When the Stratus ztC Endurance screen appears, press either the **Delete** key or the **Esc** key until the BIOS setup utility appears.
  - b. Click **Server Mgmt.**
  - c. Under **Server Mgmt**, click **BMC Network Configuration**.

- d. Scroll to **LAN Channel 1** or **LAN Channel 8** and locate **Station IP Address**. Copy the IP address, paste it into your Web browser, and press **Enter** to connect to the BMC Web console.
  - e. Log in to the BMC Web console by entering the credentials (admin and admin, if this is your first time logging in, and click **Sign me in**. (If you need more information, see ["Logging In to the BMC Web Console" on page 273.](#))
  - f. From the BMC Web console dashboard, click **Remote Control**, then click **Launch H5Viewer** (that is, the KVM).
3. From the KVM, monitor the boot process on the active compute module (**compute module A**). The system automatically boots three times. Each time, enter **F7** to display the Boot Manager screen, and then make the following selections:
  - a. At the **first** and **second** boots, select the default ubuntu option (for example, ubuntu (Micron\_MMMN\_XXXXXXXX)) and press **Enter**.
  - b. At the **third** boot, select the Stratus Maintenance option (for example, Stratus Maintenance(Micron\_MMMN\_XXXXXXXX)) and press **Enter**. At this point, the win\_sysprep.sh script, which is running on the standby compute module (compute module B), takes control of compute module A.
4. **On compute module B:**
  - a. Using the site-specific settings from ["Gathering Information" on page 148](#) that you gathered earlier, create an installation configuration file (zen\_config.yaml).
  - b. From the command line, run the following command to start the Stratus ztC Endurance Sysprep Wizard:

```
sudo /opt/stratus/bin/win_sysprep.sh -y zen_config.yaml
```
  - c. The following prompt appears: Please complete the Windows Setup configuration on peer compute module, enter new Windows password and click Finish, but do NOT login to Windows. When completed please type [Yes/Y]. **Do not respond to this prompt yet; instead, go to the next step.**
5. **On compute module A**, respond to the following prompts on the **Hi there** screen:
  - a. Select your home country, your preferred language, and your keyboard layout. Click **Next**.
  - b. Click **Accept** to accept the Microsoft Software License Terms and the Stratus End User License Agreements (EULAs).

- c. The **Customize settings** page appears with the prompt **Type a password for the built-in administrator account that you can use to sign in to this computer**. Enter your credentials and click **Finish**. The Windows login screen appears.



**Notice:** Do not log in to Windows until the installation script running on compute module B displays the `Installation completed successfully.` message.

6. **On compute module B:**

- a. Type `yes` to the prompt shown in step [4c](#) to proceed.
- b. At the `Enter the password changed during the Windows Setup` prompt, enter your password.
- c. Upon successful installation of the system, the installation script displays the `Stratus Windows Setup completed successfully.` message.
- d. Run the following command to apply the network configuration settings specified in the `zen_config.yaml` file you created earlier: `/opt/stratus/bin/net_config.sh -y zen_config.yaml`



**Note:** The command output includes the two IP addresses for connecting to the ztC Endurance console and the single IP address for connecting to the Windows host. Make a note of these IP addresses for later use.

7. **On compute module A**, log in to the Windows Administrator account, using the credentials you wrote down earlier on the **Password Settings Worksheet**.



**Notice:** The installation fails if you log in to any account other than the Windows Administrator account during this step. If this occurs, contact Penguin Solutions Customer Service.

## Next Steps

Configure your system as described in ["Post-Installation Tasks"](#) on page 184.



**Notice:** Before you configure your system, install the latest supported Windows updates as described in ["Installing Windows Updates"](#) on page 225.

## Performing a Full System Software Installation

If Penguin Solutions did not install the system software at the factory, perform a full system software installation on your ztC Endurance system:

"I. Download a Windows Server ISO Image" on page 167

"II. Power On the ztC Endurance System and Log On" on page 169

"III. Create the Installation Configuration File (Optional)" on page 169

"IV. Transfer the Windows ISO Image to the ztC Endurance System" on page 174

"V. Configure BMC Network Settings" on page 175

"VI. Installing Windows" on page 178



**Notice:** Do not perform the following procedures until you have performed all of the procedures described in "Preparing to Install the System Software" on page 148.

### I. Download a Windows Server ISO Image

#### Overview

Before starting the system software installation, download the Windows ISO image as described in "[Downloading a Windows Server ISO Image](#)" on page 168. This ISO image is used for the following editions of Windows Server:

- Windows Server 2022 (x64) Standard Edition
- Windows Server 2022 (x64) Datacenter Edition

The Microsoft Certificate of Authenticity key that you enter during or after the installation determines your edition of Windows Server.

**Notices:**

1. Download the Windows Server ISO image only as described in this topic.
2. Make sure the Windows Server ISO contains the November 2024 Windows updates and hotfixes, **at a minimum**. Earlier versions of the Windows Server ISO can cause availability issues with your ztC Endurance system. See "[Installing Windows Updates](#)" on page 225 for more information.
3. You must have a valid Microsoft Certificate of Authenticity in order to use the Windows Server ISO image.



4. The USB storage device should meet the following requirements:
  - It should be a known brand of USB storage device to ensure a successful software installation. For example, Penguin Solutions has successfully tested software installation with SanDisk® brand devices.
  - It should be a new USB storage device to avoid introducing malware to your system.
  - It should be formatted as NTFS and should have a capacity of at least 16 GB.

## Downloading a Windows Server ISO Image

To download a Windows Server ISO image

1. From a remote Windows system, click the following link to access the **Penguin Solutions Customer Service Portal**:  
<https://support.penguinolutions.com/csm>
2. Click **Login**, enter your credentials, and click **Sign In**.
3. On the **Welcome to Customer Service** page, click **Software Downloads**.
4. On the **Software Downloads** page, select your product, operating system, and model. For example, if you want to download the ISO image for a ztC Endurance system running Automated Uptime Layer with Smart Exchange for Windows, select the following values:

- a. Under **Product**, select **ztC Endurance**.
- b. Under **Operating System**, select **Windows**.
- c. Under **Model**, select the model you want.

**ztC Endurance - Windows Downloads** is displayed.

5. Click **WINServerISO**.
6. Click **Windows Server 2022 OEM ISO English-US** to download the ISO image.
7. After the download completes, use Windows commands to copy the Windows ISO image to an NTFS-formatted USB storage device. This device is not intended to be bootable.

## II. Power On the ztC Endurance System and Log On

### To power on the system and log on

1. If the ztC Endurance system is already powered on, go to step 2.  
If the ztC Endurance system is **not** already powered on:
  - a. Turn on the monitor(s).
  - b. Press the power button on the control-panel ear of the system.
2. Use the keyboard connected to compute module B to log on to the Standby OS as the zenadmin user with the default password zenadmin (or other credentials, if provided).

## III. Create the Installation Configuration File (Optional)

Optionally (but **recommended**), create an installation configuration file, `zen_config.yaml`, that contains the configuration settings that you gathered.

### Preparing the Installation Configuration File

You can optionally create an installation configuration file that contains all of the system settings you wrote down on the "[Password and Installation Settings Printable Worksheet](#)" on page 161. (Note that the installation configuration file does not contain your passwords; you are prompted for them on the command line.) This installation configuration file, `zen_config.yaml`, is a template file

located in `/opt/stratus/install` that you modify for your specific configuration. This file allows you to enter all of the configuration entries before starting the BMC configuration or software installation, thus avoiding typing mistakes during the installation. This file is also useful if you intend to install more than one system with similar parameters.

You use the same installation configuration file as input to the BMC configuration script (`bmc_config.sh`), software installation script (`install.sh`), or network configuration script (`net_config.sh`). Using this file means that you do not need to manually enter configuration settings while those scripts run.

If you exit out of the software installation script before completing the installation process, the system automatically saves a copy of your latest configuration entries in a configuration file with a time-stamped file name in the `/opt/stratus/install` directory.

#### Notes:



1. If you use an installation configuration file and leave some settings blank, the installation script prompts you on the command line for those settings.
2. In the installation configuration file, if you inadvertently enter multiple values for the same setting, the installation script uses the last setting listed in the file.

## Example of the Installation Configuration File

An example of the `zen_config.yaml` template file follows.



**Notice:** If your template file contains an entry for `windows_osname` instead of `win_osname`, change the entry to `win_osname`.

```
# SYSTEM INFORMATION
system_id:                # Use '$SYSTEM-ID$' to include in hostname con-
struction
system_domain:           # Use '$SYSTEM-DOMAIN$' to include in hostname
construction
system_nameserver:       # Use '$NAMESERVER$ to use this for nameserver fields
below or '--NONE--'
```

```

# Information shared by all components on the 1G ztC Endurance management network
# BMCs, Standby
zenmgmt_gateway: # IPv4/V6 address or None (for dhcp)
zenmgmt_netmask: # IPv4 subnet address or None (for dhcp/ipv6/(if pre-
fix supplied in ip))
zenmgmt_ipv6_prefix: # IPv6 prefix or None (for dhcp/ipv4/(if prefix sup-
plied in ip))

# BMC
bmca_hostname: $SYSTEM-ID$bmca.$SYSTEM-DOMAIN$ # BMCA hostname (may be a fully qualified domain name)
bmcb_hostname: $SYSTEM-ID$bmcb.$SYSTEM-DOMAIN$ # BMCB hostname (may be a fully qualified domain name)
bmc_netproto: # BMC IP protocol ('dhcp' or 'static')
bmca_eth0: # BMC A eth 0 IPv4/V6 address(ipaddr/prefix) or None
(for dhcp)
bmca_eth1: # BMC A eth 1 IPv4/V6 address(ipaddr/prefix) or None
(for dhcp)
bmcb_eth0: # BMC B eth 0 IPv4/V6 address(ipaddr/prefix) or None
(for dhcp)
bmcb_eth1: # BMC B eth 1 IPv4/V6 address(ipaddr/prefix) or None
(for dhcp)

# Standby
standbya_hostname: $SYSTEM-ID$a.$SYSTEM-DOMAIN$ # Standby A node hostname (may be a fully qualified
domain name)
standbyb_hostname: $SYSTEM-ID$b.$SYSTEM-DOMAIN$ # Standby B node hostname (may be a fully qualified
domain name)
standby_netproto: # Standby IP protocol ('dhcp' or 'static')
standbya_ipaddr_1: # Standby IPv4/V6 address(ipaddr/prefix) or None (for
dhcp) for A eno1
standbya_ipaddr_2: # Standby IPv4/V6 address(ipaddr/prefix) or None (for
dhcp) for A eno2
standbyb_ipaddr_1: # Standby IPv4/V6 address(ipaddr/prefix) or None (for
dhcp) for B eno1
standbyb_ipaddr_2: # Standby IPv4/V6 address(ipaddr/prefix) or None (for
dhcp) for B eno2
standby_nameserver: $NAMESERVER$ # Standby IPv4/V6 address or '--NONE--' (for dhcp)

# Windows
win_hostname: $SYSTEM-ID$. $SYSTEM-DOMAIN$ # Windows hostname (may be a fully qualified domain
name)
win_bootproto: # IP protocol ('dhcp' or 'static')
win_ipaddr: # IPv4/V6 address(ipaddr/prefix) or None (for dhcp)
win_gateway: # IPv4/V6 address or None (for dhcp)
win_netmask: # IPv4 subnet address or None (for dhcp/ipv6/(if pre-
fix supplied in ip))
win_ipv6_prefix: # IPv6 prefix or None (for dhcp/ipv4/(if prefix sup-
plied in ip))
win_nameserver: $NAMESERVER$ # IPv4/V6 address or '--NONE--'
windows_iso: # Windows ISO path/URL
win_osname: # Type of windows OS Datacenter/Standard

# Windows Management (ztC Endurance UI console)
win_mgmt_netproto: # Windows Management network protocol ('dhcp' or
'static')
win_mgmt_ipaddr1: # Windows Managemen IPv4/V6 address(ipaddr/prefix) or
None (for dhcp)
win_mgmt_ipaddr2: # Windows Managemen IPv4/V6 address(ipaddr/prefix) or
None (for dhcp)

```

```
# ASN
asn_enabled:                               # Indicates whether Support Notifications over ASN are
enabled ('yes' or 'no')
asn_asset_id:                               # Asset Identifier

# EOF
```

## Creating the Installation Configuration File

The template installation configuration file is located in the Standby OS, which runs Linux. Therefore, you need to use a Linux-based text editor, such as nano or vi, to modify the file. See ["To create or modify zen\\_config.yaml with nano" on page 172](#) to learn how to use the nano text editor, which is installed on the Standby OS, to modify the file.

To learn more about the nano text editor, see help resources on the web. For example:

<https://www.nano-editor.org/docs.php>

### Notes:

1. To use privileged commands in the zenadmin account, you need to add the sudo directive. If you open a file in nano without sudo, you cannot save the configuration file in its original, privileged directory.
2. In the examples, the dollar sign (\$) is the command-line prompt; you do not type it.
3. When the Standby OS boots, you are in the zenadmin home directory, /home/zenadmin. To modify the zen\_config.yaml file, you must change to the directory where the file is located: /opt/stratus/install.

## To create or modify zen\_config.yaml with nano

1. Change the directory from the zenadmin home directory to the directory where the template zen\_config.yaml file is located.

```
$ cd /opt/stratus/install/
```

2. Save a copy of the existing template `zen_config.yaml` file as `zen_config.yaml.orig`.

```
$ sudo cp zen_config.yaml zen_config.yaml.orig
```

3. Open the `zen_config.yaml` file with the nano text editor.

```
$ sudo nano zen_config.yaml
```

4. When the file opens, use the arrow keys to navigate as you type the settings.



**Note:** The ^ characters shown on the bottom menu indicate the  key.

5. When you finish editing the file, press `Ctrl X`, then press Y to save the changes or N to discard any changes to the file.

#### Additional considerations:

- If you forgot to use the `sudo` directive, and the system does not allow you to save the configuration file, you can save your changes to a file in the `/home/zenadmin` directory. Later, you can specify the configuration file's path name on the command line, or you can simply specify its file name if `/home/zenadmin` is the current working directory.
- When typing entries in the configuration file, you must add a space between the colon (:) and the entry text (for example, `bmca_eth0: 10.10.40.32`).
- When you are typing and moving around the file, be careful not to insert any unsupported characters or text that would prevent the installation script from properly reading the file.
- Avoid modifying the configuration file in other operating systems or word processors that might add unsupported line feeds or special characters. Use only a plain text editor such as nano.

## IV. Transfer the Windows ISO Image to the ztC Endurance System

### To transfer the Windows ISO image to the ztC Endurance system with a USB storage device

1. Mount a USB storage device in the Standby OS on compute module B:
  - a. Using the keyboard connected to compute module B, log on to the Standby OS as the zenadmin user with the default password zenadmin (or other credentials, if provided).
  - b. Connect the USB storage device to one of the USB 3.0 ports on compute module B. To locate the USB 3.0 ports, see [Figure 3-11](#).



**Notice:** Do not connect the USB storage device to the USB 2.0 port on the control-panel ear.

- c. Run the `lsblk` command to determine the Linux device name (in the format `sdxx`) for the USB storage device. In the following example, the output fragment shows that the USB storage device containing the Windows ISO was assigned the device ID of `/dev/sde1`.

```
$ lsblk
.
.
sde      8.64    1  14.6G  0  disk
|__sde1  8:65    1  14.6G  0  part   <--- USB device ID
```

- d. Create a directory as a mount point, and mount the USB storage device.



**Note:** To use privileged commands in the zenadmin account, you need to add the `sudo` directive.

```
$ sudo mkdir -p /mnt/usb
$ sudo mount /dev/sde1 /mnt/usb
```

- e. List the contents of the USB storage device to confirm that the Windows ISO is present. For example:

```
$ ls /mnt/usb
en-us_windows_server_2022_updated_nov_2024_x64_dvd_
19a258ed.iso
```

2. Copy the Windows ISO file to the Standby OS on compute module B:
  - a. Copy the Windows ISO to the /opt/stratus/install directory on the Standby OS. For example:

```
$ sudo cp /mnt/usb/en-us_windows_server_2022_updated_nov_
2024_x64_dvd_19a258ed.iso /opt/stratus/install
```

- b. Confirm that the ISO is present in that directory. (Note that the following example shows only the Windows ISO file, although the directory contains other files.)

```
$ ls /opt/stratus/install
en-us_windows_server_2022_updated_nov_2024_x64_dvd_
19a258ed.iso
```

- c. Unmount the USB storage device so that you can safely disconnect it from the compute module.

```
$ sudo umount /mnt/usb
```

## V. Configure BMC Network Settings

### Overview

Run the Baseboard Management Controller (BMC) configuration script, `bmc_config.sh`, as described in ["To configure the BMC network settings" on page 177](#). Running the BMC configuration script configures the network settings for the BMCs in the ztC Endurance system. You can also configure the BMC network settings in the system BIOS configuration utility, but the BMC configuration script simplifies the changes and allows you to change the configuration on a running system.

**Notices:**



1. If you do not run the BMC configuration script, the system automatically uses DHCP settings for the BMC network addresses and retains the default BMC Web console password.
2. If you choose to run the BMC configuration script post-installation, you will also need to run the network configuration script (`net_config.sh`).

**Notes:**



1. If you have the BMC Web console open for either compute module when you change network settings with the BMC configuration script, you will lose your connections. You need to reconnect to the new addresses you entered in the script or configuration file.
2. Although the software-installation script also prompts for changes to the same BMC settings, it is best to modify these settings with the BMC configuration script to prevent network disruptions during the installation procedure.
3. If you need to [modify DDNS settings](#), use the **DNS Configuration** page of the BMC Web Console.

The BMC configuration script is located in `/opt/stratus/bin/bmc_config.sh`.

BMC configuration script usage:

```
Usage : bmc_config.sh {options}
```

**Options:**

```
-h           prints this menu
-u url       url with ISO image location
-f filename  path to ISO image
-y filename  path to configuration yaml file
```

Run the BMC configuration script with the installation configuration file (`zen_config.yaml`) to avoid manually entering the configuration settings when running the script.



**Note:** If you run the `bmc_config.sh` script with the `zen_config.yaml` file, the BMC configuration settings are saved in a new `.yaml` file with a date and time stamp (for example, `config_26042023_180016.yaml`). You can then use the new `.yaml` file with the software installation script (`install.sh`).

## Configuring the BMC Network Settings.

### To configure the BMC network settings

1. Start the BMC configuration script by running **one** of the following commands:



**Note:** To use privileged commands in the `zenadmin` account, you need to add the `sudo` directive.

- If you created the installation configuration file: 

```
sudo /opt/stratus/bin/bmc_config.sh -y /opt/stratus/install/zen_config.yaml
```

(In the preceding command, if you installed `zen_config.yaml` in a different directory, specify that directory instead.)
- If you did not create the installation configuration file and want to respond to prompts for each setting: 

```
sudo /opt/stratus/bin/bmc_config.sh {options}
```

2. The BMC configuration script loads any existing settings from the installation configuration file and begins prompting for input.



**Note:** If you already entered the settings into the installation configuration file, the BMC configuration script prompts only for the settings you have not entered.

3. The BMC configuration script prompts for the BMC configuration settings. Type new values for the settings you need to change and press `Enter` to continue. To accept an existing value, leave the field blank and press `Enter`. Repeat until the script displays **Confirm input**.
4. The BMC configuration script displays a summary of the settings you entered and prompts you to apply the settings or prompt for each setting again to make any

corrections. Do one of the following:

- To accept the settings that you entered and apply them to the BMCs, type `y` and press `Enter`.
  - To display each prompt again with passwords hidden, type `n` and press `Enter`. For each prompt, type any changes and press `Enter` to continue.
  - To display each prompt again with passwords in clear text, type `unhide`. For each prompt, type any changes and press `Enter` to continue.
5. The BMC configuration script begins to implement the BMC settings that you specified, and then exits.
  6. View the output to confirm that the BMC configuration script completed successfully.

## VI. Installing Windows

### Overview

After running the BMC configuration script, run the software installation script, `install.sh`, as described in ["To install Windows and Automated Uptime Layer with Smart Exchange" on page 179](#). Running the software installation script automatically:

- Installs Windows
- Installs Automated Uptime Layer with Smart Exchange components
- Mirrors the pair of system disks
- Mirrors any additional disk pairs in the system, if present

The software installation script is located in `/opt/stratus/bin/install.sh`.

Software installation script usage:

```
Usage : install.sh {options}
Options:
-h           prints this menu
-u url      url with AUL-SE installer image location
-f filename path to AUL-SE installer ISO image
-y filename path to configuration yaml file
```

Run the software installation script with the installation configuration file (`zen_config.yaml`) to avoid manually entering the configuration settings when running the script.

If you exit out of the software installation script before completing the installation process, the system automatically saves a copy of your latest configuration entries in a configuration file with a time-stamped file name in the `/opt/stratus/install` directory.

The software installation takes approximately 60 minutes.

## Installing Windows and AUL-Smart Exchange

### To install Windows and Automated Uptime Layer with Smart Exchange

1. Start the software installation script by running the following command:

```
sudo /opt/stratus/bin/install.sh -y /opt/stratus/install/zen_config.yaml
```

(In the preceding command, if you installed `zen_config.yaml` in a different directory, specify that directory instead.)

The software installation script loads any existing settings from the installation configuration file and begins prompting for input.

2. Read the ztC Endurance EULA. To accept the terms and continue, type `y` and `Enter` to continue.
3. Read the ztC Endurance Service Terms and Conditions. To accept the terms and continue, type `y` and `Enter`.
4. The software installation script runs. If you already entered the settings into the installation configuration file, the installation script prompts only for the settings you have not entered. For any settings that you need to enter, see the settings you wrote down on the ["Password and Installation Settings Printable Worksheet" on page 161](#).
  - a. When prompted to configure the BMC network interfaces:
    - If you have already run `bmc_config.sh`, type `n`, and press `Enter`.
    - If you have not already run `bmc_config.sh`, type `y` to configure the interfaces now or `n` to configure them later, and press `Enter`.



**Notice:** If you are connected to the console of the compute module through the BMC Web console as described in ["Connecting to the BMC Web Console" on page 272](#), you will lose your connection if you change the BMC network settings. If applicable, consider configuring the BMC network settings at a later time as described in ["To configure the BMC network settings" on page 177](#) or ["Updating Network IP Configuration Settings" on page 222](#).

- b. Type the new BMC Web console `admin` password, the ztC Endurance Management `zenadmin` password, and the Windows Administrator password. Type each password and press `Enter` to continue.
- c. If you chose to configure the BMC network interfaces now, type the BMC hostnames. Type each entry and press `Enter` to continue.
- d. Type the BMC network protocol, `dhcp` or `static`, and press `Enter`.
- e. If you selected `dhcp`, skip to the next step; otherwise, if you selected `static`, type the four BMC IP addresses. Type each entry and press `Enter` to continue.
- f. Type the Standby hostnames for each compute module. Type each entry and press `Enter` to continue.
- g. Type the Standby network protocol, `dhcp` or `static`, and press `Enter`.
- h. If you selected `dhcp`, skip to the next step; otherwise, if you selected `static`, type the four Standby IP addresses and name server, if applicable. Type each entry and press `Enter` to continue.
- i. Type the Windows hostname and press `Enter`.
- j. Type the Windows network protocol, `dhcp` or `static`, and press `Enter`.
- k. If you selected `dhcp`, skip to the next step; otherwise, if you selected `static`, type the Windows IP address, gateway, netmask, and name server, if applicable. Type each entry and press `Enter` to continue.



- To display each prompt again with passwords hidden, type `h` and press `Enter`. For each prompt, type any changes and press `Enter` to continue.
  - To display each prompt again with passwords in clear text, type `u` or `unhide`. For each prompt, type any changes and press `Enter` to continue.
6. After you confirm your input, the software installation script begins to implement the settings that you specified and verify that all system components are ready and properly configured for installation.
  7. Read the Windows EULA. To accept the terms and continue, type `y` and `Enter`.  
  
After you accept the Windows EULA, the software installation script continues the implementation and verification process.
  8. When prompted to continue installing Windows, type `y` and `Enter` to proceed.
  9. The software installation script automatically installs Windows and begins configuring the system software. The script reboots compute module A up to four times while it completes the configuration steps, begins mirroring the pair of system disks, and then mirrors any other pairs of data disks in the system.

**Notes:**

1. The ztC Endurance system reboots when the progress bar reaches 100 percent. After the system boots, it shows that Windows is finalizing settings and then reboots again. During this second reboot:
  - The system displays the `KMODE_EXCEPTION_NOT_HANDLED` error message but does not freeze. No action is needed. The error is harmless and does not affect other parts of the installation.
  - The system may freeze for 10-15 seconds while displaying the `KMODE_EXCEPTION_NOT_HANDLED` error message. No action is needed.
  - The system may freeze while displaying the `No Signal` error message, and it loses connection to the BMC Web console. If this occurs, use the BMC Web console KVM to power off compute module A (**Power>Reset Server**) and then power it back on (**Power>Power On Server**) to continue the installation. The installation will then continue without intervention. The error is otherwise harmless and does not affect other parts of the installation.
2. If you see the message `Please monitor your Windows host. You will need to login manually after the reboot for the installation to complete.`, you can disregard it until after you see the `Installation completed successfully.` message.

10. Upon successful installation of the system, the software installation script displays the current system settings as well as the two IP addresses for the ztC Endurance console and the single IP address for the Windows host. If you have not already done so, **make note of the IP addresses now to ensure that you have this information.**

The software installation script also displays the `Installation completed successfully.` message.

**Next Steps**

Configure your system as described in "[Post-Installation Tasks](#)" on page 184.



**Notice:** Before you configure your system, install the latest supported Windows updates as described in "Installing Windows Updates" on page 225.

## Post-Installation Tasks

After installing the system software, you must complete some post-installation tasks, including:

- "Verifying the System Software Installation" on page 184
- "Configuring System-Management Options" on page 187
- "Logging In to the ztC Endurance Console for the First Time" on page 237
- "Registering the System" on page 254
- Configuring System Preferences:
  - "Specifying Owner Information" on page 254
  - "Configuring Remote Support Settings" on page 267
- "Configuring Users" on page 258
- Configuring e-Alert Notifications:
  - "Configuring the Mail Server" on page 243
  - "Configuring e-Alerts" on page 263
- "Managing Disks" on page 191
- "Configuring Network Interfaces" on page 188
- "Updating Network IP Configuration Settings" on page 222
- "Installing Windows Updates" on page 225
- "Enabling ASNConnect " on page 226
- "Changing Passwords on a ztC Endurance System" on page 229
- "Installing and Enabling Language Support" on page 190

## Verifying the System Software Installation



**Notice:** When you start or restart the Windows host, Windows requires several minutes to start. If you just restarted your system, `zen_verify` and other utilities can display proper output after 5 to 10 minutes.

To confirm that the system is configured correctly, run the following command in the Standby OS:

```
$ sudo /opt/stratus/bin/zen_verify.sh
```



**Note:** To use privileged commands in the zenadmin account, you need to add the `sudo` directive.

If your system was properly installed, the output appears similar to the following, where all of the tests have passed.

```
$ sudo /opt/stratus/bin/zen_verify.sh
Enter Windows hostname or IP address:      ocean.abc.com
Enter Windows password:
Windows authentication success
Host Windows Network check                [PASS]
Host Windows Storage Configuration check  [PASS]
Stratus Driver Version check              [PASS]
Host Windows Storage check                [PASS]
Host Windows AUL Version check            [PASS]
Host Windows OS Version check             [PASS]
Host Windows Network Teaming check        [PASS]
Standby Ubuntu OS Version check           [PASS]
Standby Ubuntu debian check               [PASS]
BMC Firmware version check                [PASS]
BIOS Firmware version check               [PASS]
SES Firmware version check                [PASS]
CPLD Firmware version check               [PASS]
Smart Exchange compatibility               [PASS]
```

The test descriptions are as follows:

- **Host Windows Network check**  
Verifies that all network adapters are teamed based on symmetric slots in both I/O modules.
- **Host Windows Storage Configuration check**  
Verifies that all disk mirrors are configured for redundant operation. That is, it checks that all disk mirrors contain two disks and are symmetrical in both I/O modules.
- **Stratus Driver Version check**  
Verifies that all Windows Automated Uptime Layer with Smart Exchange driver versions are up-to-date.

- Host Windows Storage check  
Verifies that all disks are part of mirrored LUNs.
- Host Windows AUL Version check  
Verifies that the Windows host is running the correct version of Automated Uptime Layer with Smart Exchange.
- Host Windows OS Version check  
Verifies that the Windows host is running the supported version of Windows.
- Host Windows Network Teaming check  
Verifies that at least one of the embedded PCIe adapter ports is paired.
- Standby Ubuntu OS Version check  
Verifies that the ztC Endurance Standby OS is running the supported version of the Ubuntu OS.
- Standby Ubuntu debian check  
Verifies that the ztC Endurance Standby OS contains the correct baseline packages from Debian/GNU Linux.
- BMC Firmware version check  
Verifies that the system's base management controller (BMC) firmware is up to date.
- BIOS Firmware version check  
Verifies that the system's basic input/output system (BIOS) firmware is up to date.
- SES Firmware version check  
Verifies that the system's SCSI enclosure services (SES) firmware is up to date.
- CPLD Firmware version check  
Verifies that the system's complex programmable logic device (CPLD) firmware is up to date.
- Smart Exchange compatibility  
Verifies that the compute modules are compatible for Smart Exchange. That is, the compute modules have the same BIOS version, the same ce\_mod version, and the same amount of memory.

#### Related Topics

- ["Post-Installation Tasks" on page 184](#)

## Configuring System-Management Options

Although you can manage some aspects of your ztC Endurance system from a monitor, keyboard, and mouse connected to the system (the local console), you typically manage all aspects of the Windows host from a remote management system.

For information about configuring remote system-management options for your system, see the following topics:

- ["Logging In to the ztC Endurance Console" on page 238](#) and ["Using the ztC Endurance Console" on page 235](#)

Use the ztC Endurance console to monitor system status and manage fault-tolerant aspects of your ztC Endurance system from a remote management system.

- ["Configuring the BMCs for Remote System Management" on page 187](#)

Use the BMC Web console to perform lights-out management or open a connection to the local console of the ztC Endurance system from a remote management system.

- ["Configuring the Windows Host for Remote System Management" on page 188](#)

Use Remote Desktop to log in to the Windows host from a remote management system.

- ["Configuring SSH for Remote System Management" on page 188](#)

Use a secure shell (SSH) client to log on to the Windows PowerShell utility from a remote management system and manage your ztC Endurance system at the command-line level.

### Related Topics

- ["Post-Installation Tasks" on page 184](#)

## Configuring the BMCs for Remote System Management

Use the BMC Web console to administer your ztC Endurance system from a remote management system running Windows or Linux. BMC Web console allows you to monitor the state of your system, power the system on and off, manage the configuration of your Windows host, and view Windows logs.

For more information about using the BMC Web Console, see ["Overview of the BMC Web Console" on page 271](#) and ["Accessing Documentation from the BMC Web Console" on page 274](#).

If you need to configure the BMC IP addresses, see ["V. Configure BMC Network Settings" on page 175](#).

### Related Topics

- ["Post-Installation Tasks" on page 184](#)

## Configuring the Windows Host for Remote System Management

Use Remote Desktop to configure and manage the Windows host from a remote management system.

For detailed information about using Remote Desktop, see the Windows documentation provided on the Microsoft website.

### Related Topics

- ["Post-Installation Tasks" on page 184](#)

## Configuring SSH for Remote System Management

Use a secure shell (SSH) client to log on to the Windows host from a remote system and manage your ztC Endurance system at the command-line level. You may need to download additional software to make this possible on some remote systems.

For example, to manage your ztC Endurance system from a Windows system, you can download and use PuTTY, a suite of open-source SSH clients:

<http://www.chiark.greenend.org.uk/~sgtatham/putty/download.html>

In particular, the `putty.exe` program allows you access a shell to run programs on the command line, similar to the Telnet protocol, but using secure encryption.

PuTTY also includes the `pscp.exe` command-line utility that allows you to securely transfer files from a remote system to the Windows host. For example, if necessary, you can use `pscp.exe` to transfer new firmware files or configuration files to the system.

If you prefer a secure copy (SCP) client with a graphical user interface, you can also try the open-source WinSCP utility:

<http://winscp.net/eng/index.php>

On many Linux and UNIX systems, SSH utilities are already installed and enabled by default. See `ssh(1)` and `scp(1)` for information about how to use these utilities.

### Related Topics

- ["Post-Installation Tasks" on page 184](#)

## Configuring Network Interfaces

The installation process automatically configures the embedded 10GbE ports on both I/O modules into PCIe adapter teams. During the post-installation setup, you run the `zen_team.ps1` teaming script to automatically configure the embedded 1Gbe adapters and optional, non-embedded adapters into teams. This script helps manage LBFO teams for supported PCIe adapters on ztC Endurance systems. (See ["System Specifications" on page 287](#) for a list of the supported PCIe adapters.)

The teaming script is located in the following directory:

C:\Program Files\Stratus\bin

After teams are created, they have the following names:

- Teams created from the embedded 10GbE adapters are named EMBEDDED-1 and EMBEDDED-2.
- Teams created from optional, non-embedded adapters are assigned names based on the PCIe adapter types (for example, X710-2.0 or X550-4.0).

To view team names, use `zen_team.ps1 list`. For example:

```
PS C:\Users\Administrator> & 'C:\Program Files\Stratus\bin\zen_team.ps1' list
[2024-09-25 21:48:04] [INF] Starting ztC Endurance LBFO teaming script version
[2024-09-25 21:48:04] [INF] Listing adapter info
[2024-09-25 21:48:11] [INF]
[2024-09-25 21:48:11] [INF]      Name           Device           Location         Status
MAC Address      TeamOrMembers
[2024-09-25 21:48:11] [INF]      ----           -
-----
[2024-09-25 21:48:11] [INF]      X550-1.0        TEAM            ---             Up
EE-96-91-EE-1B-58 [Ethernet 10, Ethernet 16]
[2024-09-25 21:48:11] [INF]      EMBEDDED-1     TEAM            ---             Up
EE-AD-61-FB-19-EF [Ethernet 9, Ethernet]
[2024-09-25 21:48:11] [INF]      EMBEDDED-2     TEAM            ---             Up
EE-AD-61-FB-19-EE [Ethernet 20, Ethernet 8]
[2024-09-25 21:48:11] [INF]      X710-2.0        TEAM            ---             Up
EE-A6-B7-20-C4-04 [Ethernet 18, Ethernet 4]
[2024-09-25 21:48:11] [INF]      X550-4.0        TEAM            ---             Up
EE-96-91-EE-11-30 [Ethernet 14, Ethernet 7]
[2024-09-25 21:48:11] [INF]      Ethernet 13    0000:02:00.0   CPU-0           Up
EE-AD-61-FB-16-B8
[2024-09-25 21:48:11] [INF]      Ethernet 12    0000:05:00.0   CPU-1           Up
EE-AD-61-FB-16-B9
[2024-09-25 21:48:11] [INF]      Ethernet 16    0000:C9:00.0   IOA/1-0         Up
B4-96-91-EE-0E-54 X550-1.0
[2024-09-25 21:48:11] [INF]      Ethernet 17    0000:C9:00.1   IOA/1-1         Disconnected
B4-96-91-EE-0E-55
[2024-09-25 21:48:11] [INF]      Ethernet 18    0000:CA:00.0   IOA/2-0         Up
40-A6-B7-1F-3B-40 X710-2.0
[2024-09-25 21:48:11] [INF]      Ethernet 11    0000:CA:00.1   IOA/2-1         Disconnected
40-A6-B7-1F-3B-41
[2024-09-25 21:48:11] [INF]      Ethernet 7     0000:CC:00.0   IOA/4-0         Up
B4-96-91-EE-11-30 X550-4.0
[2024-09-25 21:48:11] [INF]      Ethernet 6     0000:CC:00.1   IOA/4-1         Disconnected
B4-96-91-EE-11-31
[2024-09-25 21:48:11] [INF]      Ethernet 8     0000:CE:00.0   IOA/6-0         Up
34-AD-61-FB-19-F0 EMBEDDED-2
```

```
[2024-09-25 21:48:11] [INF] Ethernet 0000:CE:00.1 IOA/6-1 Up
34-AD-61-FB-19-F1 EMBEDDED-1
. . .
```

For more information about teaming, see ["Configuring and Managing Ethernet PCIe Adapters"](#) on page 194.

### Related Topics

- ["Post-Installation Tasks"](#) on page 184

### Installing and Enabling Language Support

Windows Server English edition includes some language interface library support, and the multilingual editions include multiple language interface support. If you want to install additional languages:

- You need Internet access to install other languages. You can also change the display language later, or switch to another installed language.
- Search the Windows online help for the procedure to download languages on your Windows operating system.
- You can change the display language later, or switch to another installed language, using the procedures described in the Windows online help.

# 8

## Chapter 8: System Software Administration (Windows)

Read the following topics to learn about tasks needed to administer a ztC Endurance system:

- ["Managing Disks" on page 191](#)
- ["Configuring and Managing Ethernet PCIe Adapters" on page 194](#)
- ["Updating Network IP Configuration Settings" on page 222](#)
- ["Configuring Windows Components" on page 225](#)
- ["Installing Windows Updates" on page 225](#)
- ["Enabling ASNConnect " on page 226](#)
- ["Installing a Custom Security Certificate" on page 227](#)
- ["Changing Passwords on a ztC Endurance System" on page 229](#)

### Managing Disks

Read the following topics to learn more about managing the disks on your ztC Endurance system:

- ["Using Storage Spaces on Data Disks" on page 191](#)
- ["Adding and Mirroring Data Disks" on page 193](#)

### Related Topics

- ["Removing and Inserting a Disk Drive" on page 114](#)
- ["Disk Drives" on page 27](#)

### Using Storage Spaces on Data Disks

You can use Windows Storage Spaces on your data disks.

In general, the Stratus implementation of Storage Spaces is very similar to the implementation described in the Windows documentation provided on the Microsoft website. This topic describes the differences.

- "Disk Requirements for Using Storage Spaces" on page 192
- "Differences When Creating RDM Disks" on page 192
- "Differences When Creating Storage Pool Virtual Disks" on page 193

For more information about Storage Spaces, see the following page on the Microsoft website:

<https://learn.microsoft.com/en-us/windows-server/storage/storage-spaces/overview>

## Disk Requirements for Using Storage Spaces

When using Storage Spaces on a ztC Endurance system, the following disk requirements apply:

- Storage Spaces is supported only on internal Rapid Disk Mirroring (RDM) data disks.
- Storage Spaces is not supported on dynamic disks, fibre-channel devices (for example, external storage systems), or USB devices.
- Storage Spaces is not recommended on any part of the boot disk.



**Notice:** Windows requires that you never select a LUN or pass-through disk to be added to a storage pool if it already contains partitions. If a LUN or pass-through disk is listed in the **PHYSICAL DISKS** menu inside the **Server Manager > File and Storage Services > Volume > Storage Pools** menu, always use Windows Disk Management to verify that it is unpartitioned before selecting it to be added to a storage pool. If the LUN or pass-through disk is partitioned, use Windows diskpart to clean the LUN or pass-through disk before adding it to a storage pool.

## Differences When Creating RDM Disks

Before you can add a new disk to a storage pool, you must create RDM disks. The Stratus-specific differences in this process are as follows:

- On the **Specify enclosure resiliency** page, the **Enable enclosure awareness** check box is always grayed out, as enclosure awareness is not supported on ztC Endurance systems.
- On the **Select the storage layout** page, select **Simple (recommended for best performance)**.

## Differences When Creating Storage Pool Virtual Disks

While running the **New Virtual Disk Wizard**, when you create a virtual disk and provide the new virtual disk name on the **Specify the virtual disk name** page, the **Create storage tiers on this virtual disk** check box is grayed out. Storage tiers do not apply to the NVMe disk drives that ztC Endurance systems support.

### Related Topics

- ["Managing Disks" on page 191](#)
- ["Disk Drives" on page 27](#)

## Adding and Mirroring Data Disks

Use Rapid Disk Mirroring (RDM) to configure and create managed disks in internal storage.

- For information about how the installation process automatically mirrors disks present in the system, see ["Mirroring Disks During the Installation " on page 193.](#)
- For information about mirroring data disks after the installation, see ["Mirroring Data Disks Post-Installation" on page 194.](#)

## Mirroring Disks During the Installation

The installation process automatically mirrors the disks in the top-left slot of each storage module into an RDM virtual disk (sometimes called a *logical unit number* or *LUN*). This RDM virtual disk becomes the system disk for the Windows host.

You can view the number of an RDM virtual disk as follows:

- In Windows **Disk Management**, RDM virtual disks appear as **Disk #** (for example, **Disk 2**).
- In the **RDM Administrator**, the `show all` command displays a row for each RDM virtual disk. Each row includes a `Phys #` (for example, 2). This number is equivalent to the number displayed as **Disk #** in **Disk Management**.

If any additional disks are present in the system during installation, the installation process automatically mirrors the disks in matching slots of each storage module into additional RDM virtual disks; however, these remaining RDM virtual disks are unformatted and unassigned.

To use the RDM virtual disks, you need to create NTFS volumes on them in Windows **Disk Management**. See the Microsoft Windows web site for more information about creating NTFS volumes.

## Mirroring Data Disks Post-Installation

If you add data disks after the installation is complete, [insert the disks](#) and then, in Windows PowerShell, use the `zen_mirror.ps1` script to mirror them.

The `zen_mirror.ps1` script is located in `\ProgramFiles\Stratus\bin` and has the following usage:

```
Usage : zen_mirror.ps1 [request]

request:
    all           Create mirrors for all internal drives
    boot         Create a mirror of the boot drive
    1..6         Create a mirror of the selected drive slot [1..6]
    list         Display the current RDM state
    help         Display this help screen (default)
```

To run the `zen_mirror.ps1` script:

```
.\zen_mirror.ps1 [request]
```



**Note:** If you use the `all` request and the system already contains mirrored disks, the `zen_mirror.ps1` output contains a message that Disk pair in slot *N* is already mirrored but otherwise ignores the existing mirrored disks.

## Related Topics

- ["Post-Installation Tasks" on page 184](#)

## Configuring and Managing Ethernet PCIe Adapters

On ztC Endurance systems, you configure and manage Ethernet PCIe adapters with Load Balancing/Failover (LBFO) technology, using the Stratus LBFO teaming script and Windows Server NIC Teaming utility to perform the following tasks:

- Configure Ethernet PCIe adapters into teams.

For planning information, see ["Teaming Utilities" on page 195](#), ["Types of Fault-Tolerant Teams" on page 202](#), and ["Fault-Tolerant Ethernet Teams and IP Multicasting" on page 202](#), if applicable.

To configure Ethernet teams, see ["Configuring Ethernet Teams" on page 204](#).

- If needed, assign virtual LANs to a team. For planning information, see ["Virtual LANs" on page 203](#). For information about how to configure the VLANs, see ["IV Configuring Virtual LANs \(VLANs\) Over a Team" on page 210](#).
- Manage a team by setting a persistent MAC address for the team, removing or adding adapters, or deleting the team. See ["Managing Ethernet Teams" on page 212](#).
- Troubleshoot a team or individual adapters. See ["Troubleshooting Ethernet Teams and Ethernet PCIe Adapters" on page 218](#).

**Notices:**

1. You can physically remove one of two partnered I/O modules without disrupting the network only if the active Ethernet PCIe adapters in both of the modules are teamed with each other. With teams configured for load balancing, your system will experience a drop in throughput while the module is absent.
2. For fault tolerance, configure your Ethernet PCIe adapters into teams. Although ztC Endurance systems support unteamed Ethernet PCIe adapters, an unteamed adapter is a single point of failure that can cause the loss of a network connection.

**Related Topics**

- ["System Software Administration \(Windows\)" on page 191](#)

**Teaming Utilities**

Two utilities allow you to manage Ethernet PCI adapters:

- Use the **Stratus LBFO teaming script** (`zen_team.ps1`), which is provided with Automated Uptime Layer with Smart Exchange, when you want to create basic, fault-tolerant teams and automatically assign persistent MAC addresses to the teams. See ["Using the LBFO Teaming Script to Manage Ethernet Teams" on page 196](#).
- Use the **Microsoft NIC Teaming utility** (`LbfoAdmin.exe`), a component of Server Manager, to configure specific teaming modes or load-balancing settings, to configure virtual LANs (VLANs), or to add, remove, or replace Ethernet PCI adapters. The ztC Endurance Help does not discuss the NIC Teaming utility in detail. For a summary of usage and restrictions, see ["Using the NIC Teaming Utility to Manage Ethernet Teams" on page 200](#).

**Related Topics**

- ["Configuring and Managing Ethernet PCIe Adapters" on page 194](#)

## Using the LBFO Teaming Script to Manage Ethernet Teams

Automated Uptime Layer with Smart Exchange includes the LBFO teaming script, `zen_team.ps1`, which automates the most common tasks associated with creating fault-tolerant teams of Ethernet PCIe adapters on a ztC Endurance system. This topic describes how to invoke the script and explains its full list of options. For procedures showing how to use the script to configure Ethernet teams on your system, see "[Configuring Ethernet Teams](#)" on page 204.

The LBFO teaming script is located at the following location:

```
C:\Program Files\Stratus\bin\zen_team.ps1
```

To use the teaming script, run the script in the Windows PowerShell utility, which is installed automatically on your system when you install Automated Uptime Layer with Smart Exchange.

### To use the teaming script

1. Log in to the ztC Endurance system using an account that has administrative privileges.
2. Start the Windows PowerShell utility. For example, click the **Start** button and click **Windows PowerShell**.  
  
If your account does not have administrative privileges, right-click **Windows PowerShell** and click **Run as Administrator**.
3. If running scripts is restricted on your system, run the following command to temporarily enable scripts, including the `zen_team.ps1` script, for the duration of this PowerShell session:

```
> set-executionpolicy -scope process unrestricted
```

```
Execution Policy Change
```

```
The execution policy helps protect you from scripts that you do not trust. Changing the execution policy might expose you to the security risks described in the about_Execution_Policies help topic at http://go.microsoft.com/fwlink/?LinkID=135170. Do you want to change the execution policy?
```

```
[Y] Yes [A] Yes to All [N] No [L] No to All [S] Suspend
```

```
[?] Help (default is "N"): y
```

You must type `y` and press `Enter` to complete the change. Later, after you finish running the script to configure teams, remember to close the PowerShell utility or set the execution policy back to `Restricted` to secure your system.



**Note:** If running scripts is restricted on your system, running a script in PowerShell will display the message `script-name cannot be loaded because running scripts is disabled on this system.`

4. Run the teaming script as follows with the desired options:

```
> & 'C:\Program Files\Stratus\bin\zen_team.ps1' [[operation] [scheme]
[teams]] [-flags [demrvc]]
```

If you run the script with no options, it displays help information for the script (that is, the `help` option is turned on by default).

Table 8-1 describes the `zen_team.ps1` script options.

#### Notices:

1. Automated Uptime Layer with Smart Exchange relies on the default naming and configuration of the team named EMBEDDED -2, which is created using a pair of embedded 10 Gb Ethernet PCIe (X710) adapters. To ensure the fault-tolerant operation of your system, do not rename, modify, or delete the default team named EMBEDDED-2. When using the `create custom` operation of the `zen_team.ps1` script, do not use the name EMBEDDED-2 for any team.
2. On a system running AUL-Smart Exchange Release 2.0, do not use the `create` operation unless instructed by your authorized Penguin Solutions service representative, because the `create` operation automatically overwrites existing teams (including the embedded 10 Gb teams) with a new team configuration. Use only the `update` operation to create or modify other teams, because it preserves existing teams.
3. Creating an Ethernet team disrupts the network traffic over all Ethernet PCIe adapters in the team.
4. Do not use Remote Desktop or SSH when creating or managing Ethernet teams, because you may lose your connection to the system when you modify the network settings. Use only the local console or the BMC KVM interface (Remote Control).



Table 8-1: `zen_team.ps1` Script Options

Option	Description
Operation	

Option	Description
create	Create all new teams (deleting existing teams)
delete	Delete existing teams/settings
update	Update teams/interfaces (preserving existing teams). For instance, use this option after replacing a compute module or I/O module.
list	Display information for each interface
savestate	Save the current state of the teams on the system to C:\Program Files\Stratus\log\team_state.json
help	Display the help screen (default)
<b>Scheme</b>	
For the create and update operations	
emb	Team the embedded PCIe adapters in the UP state (default)
up	Team all adapters in the UP state
all	Team all present adapters
custom	Create custom teams using the teams parameter. At least one configured network port in the proposed custom team must be in the UP state or the team cannot be created.
For the delete operation	
all	Delete all existing teams/settings (default)
custom	Delete a list of existing teams using the teams parameter
For the list operation	
dev	Show all interfaces, sorted by location (default)
name	Show all interfaces, sorted by name
mac	Show only custom MAC and teamed interfaces, sorted by location

Option	Description
team	Show only teamed interfaces, sorted by location
ip	Show all interface connection info, sorted by location
<b>Teams</b>	
For the create and update operations	
<i>list</i>	<p>One or more user-defined team definitions, each consisting of a team name and member locations in the form:</p> <pre>NAME=MEMBER, MEMBER [ [ , MEMBER ] . . . ]</pre> <p>where each member's location is in the form:</p> <pre>IO: SLOT: PORT (&lt;A B&gt;: &lt;1..5&gt;: &lt;0 1&gt;)</pre> <div data-bbox="472 863 1411 1161" style="border: 1px solid #00FFFF; padding: 10px; margin: 10px 0;"> <p><b>Notes:</b></p> <ol style="list-style-type: none"> <li>1. Team names must be unique and each team must contain a member from each I/O module.</li> <li>2. Custom teams may not include the embedded Ethernet PCIe adapters in slot 6.</li> </ol> </div> <p>For example, assuming valid network adapters are located in slots 1, 3, and 4 of each I/O module:</p> <pre>"TEAM-0=A:1:0,B:1:0,A:1:1,B:1:1 TEAM-1=A:4:0,B:4:0 TEAM-2=A:3:0,B:3:0,A:3:1,B:3:1,A:4:1,B:4:1"</pre> <p>Would create 3 teams:</p> <p>TEAM-0 with 4 members (IOA/1-0, IOB/1-0, IOA/1-1, IOB/1-1)</p> <p>TEAM-1 with 2 members (IOA/4-0, IOB/4-0)</p> <p>TEAM-2 with 6 members (IOA/3-0, IOB/3-0, IOA/3-1, IOB/3-1, IOA/4-1, IOB/4-1)</p>
For the delete operation	
<i>list</i>	A comma-separated list of existing team names to delete, in the form:

Option	Description
	<p><i>TEAM</i> [ [,TEAM] . . . ]</p> <p>For example:</p> <p>"TEAM-0,TEAM-1,X550-4.0"</p> <p>Would delete the existing teams whose names match (exactly):</p> <p>TEAM-0, TEAM-1, and/or X550-4.0</p>
<b>Flags</b>	
d	Delete teams on error
e	Exit if any existing team would be removed by the requested operation
m	Create management teams (debug-only)
r	Restart CPU NICs
v	Verbose logging
c	Apply network settings from the install config to the host interface

Each time the script runs, it creates a new log file named `zen_team.log` in the following folder:

C:\Program Files\Stratus\log\

For more information about using the PowerShell utility, run the `help` command in PowerShell or see the Microsoft Web site. For example:

<https://learn.microsoft.com/en-us/powershell/scripting/overview>

### Related Topics

- ["Configuring and Managing Ethernet PCIe Adapters" on page 194](#)

### Using the NIC Teaming Utility to Manage Ethernet Teams

In most cases, use the Stratus LBFO teaming script to create fault-tolerant Ethernet teams. It automates and simplifies the process of creating valid teams.

Use the Microsoft NIC Teaming utility (`LbfoAdmin.exe`), a component of Server Manager, only if you need to:

- Configure specific teaming modes or load-balancing settings
- Configure VLANs
- Add, remove, or replace individual Ethernet PCIe adapters in existing Ethernet teams

If you use the NIC Teaming utility to manage Ethernet teams, keep the following guidelines and restrictions in mind:

- If you are creating new Ethernet teams, first create them with the LBFO teaming script, then, if needed, use the NIC Teaming utility to modify the teaming modes or load-balancing settings. Initially creating teams with the LBFO teaming script automatically ensures that the teams have an Ethernet PCIe adapter from each I/O module and that the teams have a persistent MAC address assigned.
- If you use both the LBFO teaming script and NIC Teaming utility to manage Ethernet teams, use only one utility at a time to manage a team.
- Use the NIC Teaming utility only when both partnered I/O modules are online. All NICs to be teamed must be present and enabled to be added to a team. If you examine a team with the NIC Teaming utility when some team members are not present, the utility may fail. See [NIC Teaming Utility Fails When a CPU-I/O Enclosure Is Offline](#).
- In the NIC Teaming utility, click **OK** in each dialog box to preserve your changes. If you do not click **OK** before closing the dialog box, the configuration procedure is incomplete, and you must repeat it.

### To start Windows Server Manager

1. Log on to the ztC Endurance system using an account that has administrative privileges.
2. Start **Server Manager**. For example, click the **Start** button and click **Server Manager**.

If your account does not have administrative privileges, right-click **Server Manager** and click **Run as Administrator**.

### To use NIC Teaming to manage Ethernet PCIe adapters

1. In **Server Manager**, click **All Servers**.
2. In the Servers list, right-click the server name and click **Configure NIC Teaming**.
3. In the **NIC Teaming** window, select an individual adapter or team to configure or manage.

### Related Topics

- ["Configuring and Managing Ethernet PCIe Adapters" on page 194](#)

## Types of Fault-Tolerant Teams

You can configure Ethernet PCIe adapters into teams to increase fault tolerance, performance, or both.

In some teams, one Ethernet PCIe adapter is the active adapter (or primary adapter), and all other Ethernet PCIe adapters are standby (or secondary) adapters; a standby adapter becomes active only if the active adapter fails. In other teams, most or all members of the team actively pass traffic to increase overall transmit or receive throughput.

Typically, the permanent Media Access Control (MAC) address (or Ethernet Address) of the primary Ethernet PCIe adapter becomes the current MAC address for all Ethernet PCIe adapters in one team.

The `zen_team.ps1` teaming script automatically creates Ethernet teams in a **switch-independent** configuration with **active/active teaming** and **dynamic- distribution load balancing**.

- **Switch-independent mode.** The team does not require the Ethernet switch to participate in the teaming. The switch does not know that the Ethernet PCIe adapter is part of a team in the host. The adapters may be connected to different switches, if applicable.
- **Active/active teaming.** Two or more Ethernet PCIe adapters provide redundant connections to the network. The active adapter(s) execute all transmit and receive functions for the team. If you optionally configure a standby adapter, it becomes active only if a failover occurs (typically, if an active adapter fails).
- **Dynamic-distribution load balancing.** Outbound loads are distributed in real time based on a hash of the TCP ports and IP addresses. Inbound loads are distributed by the destination MAC address (or VM MAC address), as if Hyper-V switch port distribution were in use.

These are the only teaming modes that you can create and manage with the `zen_team.ps1` script.

You can assign any Ethernet PCIe adapter that Stratus supplies to any type of team supported by the NIC Teaming utility.

### Related Topics

- ["Configuring and Managing Ethernet PCIe Adapters" on page 194](#)

## Fault-Tolerant Ethernet Teams and IP Multicasting

If IP multicasting is in use on your network, consider the following restriction when choosing the type of fault-tolerant team to configure.

Each network host in an IP multicast group uses the Internet Group Management Protocol (IGMP) to acknowledge and maintain its IP multicast group membership with a switch.

In some LBFO team configurations, it is possible that only one Ethernet PCIe adapter (the active adapter) is registered to receive IP multicast packets. When failover to another adapter occurs, the host cannot automatically update its multicast group membership using the new active adapter;

therefore, the host stops receiving multicast packets. If the switch is configured to periodically query the host for its registration, or if static IGMP is configured on the switch for each adapter in the team, multicasting to the host will eventually resume, but possibly after an extended interruption.

If you use IP multicasting, you should test the team configuration on site to verify if the behavior of IP multicasting after failover is acceptable. Alternatively, you can configure either static or dynamic link aggregation teams. IP multicasting functions more reliably with qualified switches that support these modes, because all Ethernet PCIe adapters in a link aggregation team are registered to receive the IP multicast packets. The team continues to receive IP multicast packets unless all links to the switch are lost and then restored (in which case, there is also an extended interruption).

For more information about IP multicasting, see the documentation for your switch, or contact your network administrator.

### Related Topics

- ["Configuring and Managing Ethernet PCIe Adapters" on page 194](#)

### Virtual LANs

You can add a Virtual LAN (VLAN) to any type of Ethernet team as described in ["IV Configuring Virtual LANs \(VLANs\) Over a Team" on page 210](#).

A VLAN allows you to isolate network traffic for a specific group of network hosts. Using VLANs, you can organize networked systems into logical workgroups, such as Marketing or Engineering, that span a building, complex, or an entire enterprise network. Members of a particular VLAN receive traffic only from other members of the same VLAN.

VLANs are particularly useful for limiting broadcast storms, reducing security problems, and simplifying network management.

There are two types of VLANs:

- Implicit VLANs, which are configured entirely at the switch level. The switch does not alter or tag packets to enforce an implicit VLAN.
- Explicit VLANs, which are configured throughout the network, on each adapter and link partner. Switches identify and route traffic based on a four-byte tag (802.3ac) in each packet header.

To support either type of VLAN, switches on your network must support 802.1Q VLANs. Also, to configure a VLAN on your system, you need to contact your network administrator to obtain the VLAN ID for your workgroup, which must be identical to the VLAN ID programmed into the switches.

In an environment with many VLAN workgroups, you can optionally implement the Generic Attribute Registration Protocol (GARP) VLAN Registration Protocol (GVRP) to dynamically create, change, and remove VLANs. To support GVRP, all adapters and switches on your network must have GVRP

enabled. For more information about GVRP, follow the links in the online help available on the VLANs tab, see the documentation for your switch, or contact your network administrator.

### Related Topics

- ["Configuring and Managing Ethernet PCIe Adapters" on page 194](#)

### Configuring Ethernet Teams

Use the load balancing and failover (LBFO) teaming script, `zen_team.ps1`, to configure Ethernet PCIe adapters into teams. When you create a team, keep the following guidelines and restrictions in mind:

- Each port on a dual-port Ethernet PCIe adapter appears as a separate adapter in the teaming script.
- Generally, assign Ethernet PCIe adapters of only one media type (fiber optic or copper) to a team.
- By default, speed and duplex mode are autonegotiated. Autonegotiation will result in incorrect duplex settings if one side of the link is set to autonegotiate and the other side of the link is not. Always confirm how the switch ports that will be connected to the network ports on the server are configured, and configure the network ports on the server the same way. Always use the same data rate and duplex mode values for all members of a team.
- There is no minimum or maximum number of teams to be configured. Teams are limited only by the number of adapters available on your system and how you allocate them.
- For fault tolerance, create teams that contain Ethernet PCIe adapters from different I/O modules. Only teams with Ethernet PCIe adapters in different I/O modules are fault tolerant.

In addition, Stratus does not support the following:

- Modifying the default embedded 10Gb Ethernet PCIe adapter teams.
- Teaming third-party Ethernet PCIe adapters with Stratus Ethernet PCIe adapters.

Only Stratus Ethernet PCIe adapters have been tested for compatibility and fault tolerance in ztC Endurance systems.

To configure Ethernet PCIe adapters into fault-tolerant teams, perform the following procedures in the order listed:

["I. Preparing to Use the LBFO Teaming Script" on page 205](#)

["II. Displaying the Current Configuration of Ethernet PCIe Adapters" on page 206](#)

["III. Creating Ethernet Teams" on page 207](#)

["IV. Configuring Virtual LANs \(VLANs\) Over a Team" on page 210](#)

["V. Assigning an IP address to a Team or VLAN" on page 211](#)

## I. Preparing to Use the LBFO Teaming Script

If applicable, ensure that you have installed any non-embedded Ethernet PCIe adapters in matching slots of each I/O module, as described in ["To install a PCIe adapter" on page 125](#). For additional information about non-embedded Ethernet PCIe adapters, including the recommended slot assignment for optimal performance, see ["PCIe Adapters" on page 30](#).

If you are using the LBFO teaming script for the first time, optionally see ["Using the LBFO Teaming Script to Manage Ethernet Teams" on page 196](#) to learn more about the script and the full list of options that are available.

When you are ready to use the LBFO teaming script, perform the following steps to modify the execution policy of a PowerShell session to allow the script to run on your system.

### To allow the LBFO teaming script to run on your system

1. Log in to the ztC Endurance system using an account that has administrative privileges.
2. Start the Windows PowerShell utility. For example, click the **Start** button and click **Windows PowerShell**.

If your account does not have administrative privileges, right-click **Windows PowerShell** and click **Run as Administrator**.

3. If running scripts is restricted on your system, run the following command to temporarily enable scripts, including the `zen_team.ps1` script, for the duration of this PowerShell session:

```
> set-executionpolicy -scope process unrestricted
```

```
Execution Policy Change
```

```
The execution policy helps protect you from scripts that you do not trust. Changing the execution policy might expose you to the security risks described in the about_Execution_Policies help topic at http://go.microsoft.com/fwlink/?LinkID=135170. Do you want to change the execution policy?
```

```
[Y] Yes [A] Yes to All [N] No [L] No to All [S] Suspend  
[?] Help (default is "N"): y
```

You must type `y` and press `Enter` to complete the change. Later, after you finish running the script to configure teams, remember to close the PowerShell utility or set the execution policy back to Restricted to secure your system.



**Note:** If running scripts is restricted on your system, running a script in PowerShell will display the message `script-name cannot be loaded because running scripts is disabled on this system.`

## II. Displaying the Current Configuration of Ethernet PCIe Adapters

Before creating Ethernet teams, use the `list` option of the LBFO teaming script to list all Ethernet PCI adapters in the system and show their location, teaming status, and additional information. Ensure that the Ethernet PCI adapters that you want to use to create teams are enabled and available for teaming.

### To show a list of all Ethernet PCI adapters in the system

1. If you have not already done so, open the Windows PowerShell utility and prepare to run the `zen_team.ps1` script, as described in "To allow the LBFO teaming script to run on your system" on page 205.
2. Run the `zen_team.ps1` command to show all of the adapters in the system:

```
> & 'C:\Program Files\Stratus\bin\zen_team.ps1' list
```

The following example shows the default configuration, where only the embedded Ethernet PCI adapters are teamed. All other adapters are available to be teamed.

```
> & 'C:\Program Files\Stratus\bin\zen_team.ps1' list
Starting ztC Endurance LBFO teaming script
Listing adapter info
Name           Device           Location          Status           MAC Address
TeamOrMembers
-----
-----
-----
EMBEDDED-1     TEAM             ---              Up              00-AD-61-FB-19-EF
[Ethernet, Ethernet 12]
EMBEDDED-2     TEAM             ---              Up              00-04-FC-F1-1F-CA
[Ethernet 4, Ethernet 11]
Ethernet 2     0000:02:00.0     CPU-0            Up              00-04-FC-F1-1F-C8
```

Ethernet 9	0000:05:00.0	CPU-1	Up	00-04-FC-F1-1F-C9
Ethernet 7	0000:C9:00.0	IOA/1-0	Up	B4-96-91-D1-B2-C4
Ethernet 8	0000:C9:00.1	IOA/1-1	Up	B4-96-91-D1-B2-C5
Ethernet 4	0000:CE:00.0	IOA/6-0	Up	34-AD-61-FB-18-8C
EMBEDDED-2				
Ethernet	0000:CE:00.1	IOA/6-1	Up	34-AD-61-FB-18-8D
EMBEDDED-1				
Ethernet 10	0000:9D:00.0	IOB/1-0	Up	B4-96-91-D1-B8-A0
Ethernet 3	0000:9D:00.1	IOB/1-1	Up	B4-96-91-D1-B8-A1
Ethernet 11	0000:A2:00.0	IOB/6-0	Up	34-AD-61-FB-18-8E
EMBEDDED-2				
Ethernet 12	0000:A2:00.1	IOB/6-1	Up	34-AD-61-FB-18-8F
EMBEDDED-1				

### III. Creating Ethernet Teams

By default, Automated Uptime Layer with Smart Exchange creates an Ethernet team for each pair of matching 10GbE embedded adapter ports that is connected (in an UP state) at installation time. The following procedure describes how to create Ethernet teams for any additional non-embedded Ethernet PCIe adapters in your system.

As described in "[Types of Fault-Tolerant Teams](#)" on page 202, the LBFO teaming script automatically creates teams in a **switch-independent** configuration with **active/active** teaming and **dynamic distribution** load balancing.

When you create Ethernet teams with the LBFO teaming script:

- All specified Ethernet PCIe adapters must be present, enabled, and unteamed. Each adapter must also have an active network connection (must be in an UP state).
- The LBFO teaming script does not check for Ethernet PCIe adapter types or link speeds, so you must ensure that the Ethernet PCIe adapters are of the same type and link speed.
- Creating Ethernet teams may take a minute or two to complete.
- When you create custom teams, you must specify at least two ports, and the team must include a port in each I/O module.

**Notices:**



1. Automated Uptime Layer with Smart Exchange relies on the default naming and configuration of the team named EMBEDDED -2, which is created using a pair of embedded 10 Gb Ethernet PCIe (X710) adapters. To ensure the fault-tolerant operation of your system, do not rename, modify, or delete the default team named EMBEDDED-2. When using the create custom operation of the zen\_team.ps1 script, do not use the name EMBEDDED-2 for any team.
2. On a system running AUL-Smart Exchange Release 2.0, do not use the create operation unless instructed by your authorized Penguin Solutions service representative, because the create operation automatically overwrites existing teams (including the embedded 10 Gb teams) with a new team configuration. Use only the update operation to create or modify other teams, because it preserves existing teams.
3. Creating an Ethernet team disrupts the network traffic over all Ethernet PCIe adapters in the team.
4. Do not use Remote Desktop or SSH when creating or managing Ethernet teams, because you may lose your connection to the system when you modify the network settings. Use only the local console or the BMC KVM interface (Remote Control).

**To create basic Ethernet teams**

1. If you have not already done so, open the Windows PowerShell utility and prepare to run the zen\_team.ps1 script, as described in "[To allow the LBFO teaming script to run on your system](#)" on page 205.
2. Run the create operation to automatically team the Ethernet PCIe adapters in the ztC Endurance system:  

```
> & 'C:\Program Files\Stratus\bin\zen_team.ps1' create
```
3. After the script completes, do the following:
  - If needed, configure VLANs. See "[IV Configuring Virtual LANs \(VLANs\) Over a Team](#)" on page 210.

- If needed, configure the TCP/IP settings for the new team. See "[V. Assigning an IP address to a Team or VLAN](#)" on page 211.

### To create a custom Ethernet team

1. If you have not already done so, open the Windows PowerShell utility and prepare to run the `zen_team.ps1` script, as described in "[To allow the LBFO teaming script to run on your system](#)" on page 205.
2. Run the `update custom` operation to create a new custom Ethernet team without modifying existing teams:

```
> & 'C:\Program Files\Stratus\bin\zen_team.ps1' update custom
"NAME=MEMBER, MEMBER[, MEMBER]..."
```

See **Examples** below for how to specify the *teams* parameters. For the full list of options, see "[Using the LBFO Teaming Script to Manage Ethernet Teams](#)" on page 196.

3. After the script completes, do the following:
  - If needed, configure VLANs. See "[IV Configuring Virtual LANs \(VLANs\) Over a Team](#)" on page 210.
  - If needed, configure the TCP/IP settings for the new team. See "[V. Assigning an IP address to a Team or VLAN](#)" on page 211.

### Examples

These examples assume that valid network adapters are already located in the physical I/O slots.

The following example creates a simple custom team containing two ports, one from each Ethernet PCIe adapter located in slot 1 of each I/O module:

```
> & 'C:\Program Files\Stratus\bin\zen_team.ps1' update custom "TEAM-
0=A:1:0,B:1:0"
```

The following example creates a similar custom team containing four ports, two from each Ethernet PCIe adapter located in slot 1 of each I/O module:

```
> & 'C:\Program Files\Stratus\bin\zen_team.ps1' update custom "TEAM-
0=A:1:0,B:1:0,A:1:1,B:1:1"
```

The following example creates two custom teams:

- TEAM-1 containing two ports, one from each Ethernet PCIe adapter located in slot 4 of each I/O module.
- TEAM-2 containing six ports, two from each Ethernet PCI adapter located in slot 3 and one from each adapter located in slot 4 of each I/O module.

```
> & 'C:\Program Files\Stratus\bin\zen_team.ps1' update custom "TEAM-1=A:4:0,B:4:0 TEAM-2=A:3:0,B:3:0,A:3:1,B:3:1,A:4:1,B:4:1"
```

The next example shows output where the LBFO teaming script aborts creating a custom team containing two Ethernet PCIe adapters because the resulting team would contain adapters from the same I/O module, which would not be fault tolerant.

```
> & 'C:\Program Files\Stratus\bin\zen_team.ps1' update custom "TEAM-0=A:1:0,A:1:1"
Starting ztC Endurance LBFO teaming script version n.n.n.nnn
Updating existing teams
Creating team list ...
Teams must include members from both IOs (TEAM-0=A:1:0,A:1:1)
Exiting
```

To create the team from the preceding example, select matching Ethernet PCIe adapters from different I/O modules (for example, A:1:0 and B:1:0) and run the script again.

## IV Configuring Virtual LANs (VLANs) Over a Team

Configuring VLANs is optional. You can have an Ethernet team without VLANs. For an overview of VLANs, see ["Virtual LANs" on page 203](#).

If VLANs are needed, use the Microsoft NIC Teaming utility to create them.

### Notices:



1. Configuring a VLAN over an Ethernet team disrupts the network traffic over the team.
2. If you create multiple VLAN interfaces for a team, you must set a persistent MAC address for each additional VLAN interface, as described in ["Setting the Locally Administered Address for a Team or VLAN" on page 213](#).

**To create a VLAN for the default team interface**

1. In the NIC Teaming utility, under **ADAPTERS AND INTERFACES**, click the **Team Interfaces** tab.
2. On the **Team Interfaces** tab, expand the team on which you want to configure a VLAN, click the default team interface, and select **Properties**.
3. Under **VLAN membership**, click **Specific VLAN** and specify a VLAN ID.

As you enter the VLAN ID, the NIC Teaming utility modifies the name of the team to include the VLAN ID. For example, if you enter **120** in the **Specific VLAN** field, the utility automatically appends **VLAN 120** to the team name.

4. Click **OK** to apply the change and close the dialog box.
5. If you created the team with the NIC Teaming utility, set a persistent MAC address for the default team interface, as described in ["Setting the Locally Administered Address for a Team or VLAN" on page 213](#).

(If you initially create a team with the LBFO teaming script, it automatically sets the MAC address for the default teaming interface, but not additional VLAN interfaces.)

If you need to create additional VLAN interfaces, use the following procedure.

**To create additional VLAN interfaces for a team**

1. On the **Team Interfaces** tab, expand the team on which you want to configure a VLAN and click a team interface to select the team.
2. Click the **Tasks** pull-down menu and select **Add Interface**.
3. Under **VLAN membership**, click **Specific VLAN** and specify a VLAN ID.
4. Click **OK** to apply the change and close the dialog box.
5. If needed, repeat steps 1-4 to create additional VLAN interfaces.
6. Set a persistent MAC address for each VLAN interface that you added, as described in ["Setting the Locally Administered Address for a Team or VLAN" on page 213](#).

**V. Assigning an IP address to a Team or VLAN**

1. To start managing network connections, click the **Start** button, **Control Panel**, **Network and Internet**, and then **Network and Sharing Center**.

2. In the window that appears, under **View your active networks**, click the entry for the team or VLAN connection.
3. In the connection **Status** window, click **Properties**.
4. In the connection **Properties** dialog box, click Internet Protocol Version 6 (TCP/IPv6) or Internet Protocol Version 4 (TCP/IPv4), and then click **Properties**.
5. In the **Properties** dialog box, select whether you want to specify an IP address or obtain the IP address automatically. If you specify an IP address, enter the IP address, subnet mask, and default gateway. Consult your network administrator for all TCP/IP property settings.



**Note:** Your TCP/IP property settings must match the configuration of the network to which the team or VLAN is connected. Your system can obtain the IP address automatically only if the network supports it. If you choose the option to obtain the IP address automatically and the network does not support it, the team may be unusable.

6. Click **OK** to accept the changes.
7. In the **Properties** dialog box, click **Close** to process the new TCP/IP settings and to close the dialog box.
8. In the **Network and Sharing Center** window, click the entry for the team or VLAN that you modified and click **Details**. Verify that the new IP address appears in the **Network Connection Details** window.

## Related Topics

- ["Configuring and Managing Ethernet PCIe Adapters" on page 194](#)

## Managing Ethernet Teams

The following sections explain how to manage teams:

- ["Setting the Locally Administered Address for a Team or VLAN" on page 213](#)
- ["Removing Ethernet PCIe Adapters from a Team" on page 215](#)
- ["Physically Replacing Removed Adapters" on page 216](#)
- ["Adding Ethernet PCIe Adapters to a Team" on page 217](#)
- ["Deleting Ethernet Teams" on page 218](#)

**Notices:**



1. Whenever you modify an existing team, you might temporarily interrupt the flow of network traffic to the team.
2. When you add or remove Ethernet PCI adapters in a team that uses LBFO Static Teaming mode, the link to the adapters you are adding or removing must be down; otherwise, the switch forwards traffic to the adapters before the configuration is complete.
3. When you remove or replace a teamed adapter, you might need to reset the MAC address of the team as described in "[Setting the Locally Administered Address for a Team or VLAN](#)" on page 213. In addition, contact your network administrator to update any network filtering or security settings that are based on the MAC address of the Ethernet PCI adapter you removed.

**Related Topics**

- "[Configuring and Managing Ethernet PCIe Adapters](#)" on page 194

**Setting the Locally Administered Address for a Team or VLAN**

The Locally Administered Address (LAA), a persistent MAC address, must be set for each Ethernet team and VLAN to ensure that the MAC address will not change when you reboot the system or temporarily remove an I/O module.

If you initially create teams with the LBFO teaming script, it automatically sets the LAA for each team; however, you may need to manually set the LAA if you:

- Remove or replace an adapter in an existing team.
- Add more than one VLAN interface to a team.
- Initially create teams with the NIC teaming utility instead of the LBFO teaming script.

Typically, a team's LAA is the same as the MAC address of the primary adapter in the team. If you replace the primary adapter, the team continues to use the LAA that matches the MAC address of the original primary adapter unless you manually update the LAA to match the MAC address of the new primary adapter. If you have configured multiple VLAN interfaces for the team, you must also update the LAA for each VLAN interface to the new primary MAC address.



**Notice:** Set the LAA only on team or VLAN interfaces. Do not set the LAA for the individual Ethernet PCIe adapters in the team.

## To set the LAA for a team or VLAN

1. Use the LBFO teaming script `list` operation to display the adapter name and MAC address with each Ethernet PCIe adapter and team as shown in "II. Displaying the Current Configuration of Ethernet PCIe Adapters" on page 206.
2. In the NIC Teaming utility, under **ADAPTERS AND INTERFACES**, click the **Team Interfaces** tab.
3. On the **Team Interfaces** tab, expand the target team, click the team interface (or the first interface if more than one is present), and select **Properties**.
4. Under **General information**, make note of the **Description** and **Permanent address** of the team interface. The description should be similar to **Microsoft Network Adapter Multiplexor Driver #n** and the permanent address should match the MAC address of one of the adapters currently in the team, which you collected in step 1.



**Note:** Although the NIC teaming utility displays the **Permanent address** for the team, the address is not persistent until you complete this procedure, which preserves the team's MAC address in the system registry.

5. Open **Device Manager** and expand **Network adapters**.
6. Locate the team interface, which is listed in **Device Manager** by the **Description** you collected in step 4. Because each team has a similar description, ensure that you select the correct entry.
7. Right-click the team interface and select **Properties**.
8. In the **Properties** dialog box, click the **Advanced** tab.
9. Locate and click the **MAC Address** property. Under **Value**, carefully type the MAC address for the team (or **Permanent address**), which you confirmed in step 4.  
  
When typing the address, do not include any dashes (-), colons (:), or spaces. For example, if the address is A0-36-9F-5A-BA-C0, type A0369F5ABAC0.
10. Click **OK** to set the address and close the dialog box.
11. If the team has multiple interfaces (including VLANs), repeat steps 3-10.

After setting the LAA, confirm the setting by using one of the following procedures.

## To confirm the LAA is set for a team or VLANs with Windows PowerShell

You can verify that the LAA has been set by running a command similar to the following in Windows PowerShell, where *team-name* is the name of the default team interface or VLAN interface:

```
PS> (Get-netadapterAdvancedProperty -Name team-name* -RegistryKeyword
NetworkAddress).DisplayValue
```

Inserting the wildcard (\*) with the team-name\* displays information for all interfaces associated with the team (including VLANs, if present), as follows:

```
> (Get-NetAdapterAdvancedProperty -Name Embedded-* -RegistryKeyword Net-
workAddress)
Name           DisplayName  DisplayValue  RegistryKeyword  RegistryValue
----           -
EMBEDDED-2    MAC Address  0004FCF82F12  NetworkAddress  {0004FCF82F12}
EMBEDDED-1    MAC Address  0004FCF82F13  NetworkAddress  {0004FCF82F13}
```

The preceding example shows that the LAA has been set for both embedded teams and that no further action is needed.

### Related Topics

- ["Managing Ethernet Teams" on page 212](#)
- ["Configuring and Managing Ethernet PCIe Adapters" on page 194](#)

## Removing Ethernet PCIe Adapters from a Team

### Notices:



1. Automated Uptime Layer with Smart Exchange relies on the default naming and configuration of the team named EMBEDDED -2, which is created using a pair of embedded 10 Gb Ethernet PCIe (X710) adapters. To ensure the fault-tolerant operation of your system, do not rename, modify, or delete the default team named EMBEDDED-2. When using the create custom operation of the zen\_team.ps1 script, do not use the name EMBEDDED-2 for any team.
2. Modifying an Ethernet team disrupts the network traffic over all Ethernet PCIe adapters in the team.
3. Before you remove an Ethernet PCIe adapter from a team, check that the team's MAC address is not the same as that of the adapter being removed. If it is the same, change the team's MAC address to match the address of an adapter that remains in the team.



**Note:** Remove Ethernet PCIe adapters from only one team at a time. Complete the procedure before removing an adapter from another team.

1. Use the instructions in "[II. Displaying the Current Configuration of Ethernet PCIe Adapters](#)" on [page 206](#) to determine the adapter name (Ethernet *nn* or I/Ox/*n-n*) and MAC address for the Ethernet PCIe adapter that you want to remove. (You will need the MAC address later for "[Setting the Locally Administered Address for a Team or VLAN](#)" on [page 213](#).)
2. In the NIC Teaming utility, under **ADAPTERS and INTERFACES**, click the **Network Adapters** tab. Locate and expand the team from which you want to remove an adapter.
3. Right-click the adapter that you want to remove, select **Remove from team *name*** from the pull-down menu, and click **Remove from team** to apply the change.
4. Verify that the removed adapter returns to the list of available adapters.

If you are not physically replacing the Ethernet PCI adapters that you removed, update the MAC address of the team at this time. See "[Setting the Locally Administered Address for a Team or VLAN](#)" on [page 213](#).

### Related Topics

- "[Managing Ethernet Teams](#)" on [page 212](#)
- "[Configuring and Managing Ethernet PCIe Adapters](#)" on [page 194](#)

### Physically Replacing Removed Adapters

If you intend to physically replace the adapters that you remove, complete the following procedure.



**Notice:** You must remove an adapter from the team in the NIC Teaming utility before physically removing the adapter from the system. The NIC Teaming utility may not work properly if a teamed adapter is not present.

### To physically replace adapters in a team

1. If you intend to maintain network connectivity while removing an I/O module, verify that all active Ethernet PCIe adapters in the module are teamed with adapters in another module. See "[II. Displaying the Current Configuration of Ethernet PCIe Adapters](#)" on [page 206](#) to determine the location of Ethernet PCIe adapters in the system.
2. Use the NIC Teaming utility to remove the adapters from the team, as described in "[Removing Ethernet PCIe Adapters from a Team](#)" on [page 215](#).
3. Close the NIC Teaming utility.
4. Physically remove the Ethernet PCIe adapters from the system and install the new adapters. For more information about removing and replacing adapters, see the operation and maintenance

guide for your system.



**Note:** If you intend to use the old Ethernet PCIe adapters in other systems, do not install them in other systems until you reset the MAC address of the team.

5. Add the new Ethernet PCIe adapters to the team, as ["Adding Ethernet PCIe Adapters to a Team" on page 217](#) describes.

#### Related Topics

- ["Managing Ethernet Teams" on page 212](#)
- ["Configuring and Managing Ethernet PCIe Adapters" on page 194](#)

#### Adding Ethernet PCIe Adapters to a Team



**Note:** Add Ethernet PCIe adapters to only one team at a time. Complete the procedure before adding an adapter to another team.

1. In the NIC Teaming utility, under **TEAMS**, select the team to which you want to add an adapter.
2. Under **ADAPTERS and INTERFACES**, click the **Network Adapters** tab. Locate an adapter that you want to add to the team. Right-click the adapter and select **Add to team *name***, where *name* is the team you selected in step 1.

Repeat this step for any adapters you want to add to the team.

3. Under **ADAPTERS and INTERFACES**, verify that the adapters you added now appear under the appropriate team entry.
4. If necessary, reset the MAC address for the team. See ["Setting the Locally Administered Address for a Team or VLAN" on page 213](#).
5. If necessary, connect the new Ethernet PCIe adapters to the network.

#### Related Topics

- ["Managing Ethernet Teams" on page 212](#)
- ["Configuring and Managing Ethernet PCIe Adapters" on page 194](#)

## Deleting Ethernet Teams

### Notices:



1. Automated Uptime Layer with Smart Exchange relies on the default naming and configuration of the team named EMBEDDED -2, which is created using a pair of embedded 10 Gb Ethernet PCIe (X710) adapters. To ensure the fault-tolerant operation of your system, do not rename, modify, or delete the default team named EMBEDDED-2. When using the create custom operation of the zen\_team.ps1 script, do not use the name EMBEDDED-2 for any team.
2. When you delete a team, you lose the connection to the network until you install and configure a new team.
3. If you assigned a specific IP address to the team, and if you are planning to configure a new team to use the same IP address, note the IP address of the team when you remove it. An assigned IP address is deleted when you remove the team.

Use the NIC Teaming utility to delete an Ethernet team.

### To delete a single Ethernet team

1. In the NIC Teaming utility, under **TEAMS**, locate the team that you want to delete.
2. Right-click the team that you want to delete, select **Delete** from the pull-down menu, and click **Delete team** to apply the change.
3. Verify that the adapters that were in the team return to the list of available adapters.

### Related Topics

- ["Managing Ethernet Teams" on page 212](#)
- ["Configuring and Managing Ethernet PCIe Adapters" on page 194](#)

### Troubleshooting Ethernet Teams and Ethernet PCIe Adapters

See the following information to resolve problems with LBFO teams and Ethernet PCI adapters:

- ["Fixing Duplicate Network Adapter Names" on page 219](#)
- ["Avoid Disabling an LBFO Team" on page 219](#)
- ["NIC Teaming Utility Fails When an I/O Module Is Offline" on page 220](#)
- ["NIC Teaming Utility Fails If the Host Name Changes" on page 221](#)

- **Related Topics**

- ["Configuring and Managing Ethernet PCIe Adapters" on page 194](#)

## Fixing Duplicate Network Adapter Names

Duplicate Network Adapter names may appear in Device Manager after the initial software installation or when adding Ethernet PCIe adapter cards. The duplicate names will cause incorrect reporting of network information, in which case, teamed adapters will not be duplexed.

### To fix duplicate network adapter names

1. Delete any teams that contain adapters with duplicate names.
2. In **Device Manager**, right-click an adapter with a duplicate name, and select **Uninstall** on the drop-down menu to uninstall the adapter. Repeat for other adapters with duplicated names.
3. Use the **Scan for hardware changes** command to reconfigure the network adapters with unique names. To use **Scan for hardware changes**:
  - a. Select **Device Manager**.
  - b. In **Device Manager**, expand **Network adapters**.
  - c. Right-click the target adapter and select **Scan for hardware changes**.
4. Create any required teams again.

Use Windows Remote Desktop if you need to start Device Manager remotely. You can then create or modify a team **if it is not carrying your connection to the system**.



**Notice:** Modifying the team that provides your connection to the system will result in a loss of network connection.

### Related Topics

- ["Troubleshooting Ethernet Teams and Ethernet PCIe Adapters" on page 218](#)
- ["Configuring and Managing Ethernet PCIe Adapters" on page 194](#)

## Avoid Disabling an LBFO Team

To prevent problems with NIC teaming, avoid disabling LBFO teams. If you disable a team interface, and the individual Ethernet PCIe adapters are still active, the system continually restarts the adapters in an attempt to get the team working again.

If you do need to disable a team, disable the team and also each individual Ethernet PCIe adapter that is part of the team. You can disable network interfaces in **Device Manager** or in the **Network and**

**Sharing Center** by clicking **Change adapter settings** to access controls in the **Network Connections** window.

### Related Topics

- ["Troubleshooting Ethernet Teams and Ethernet PCIe Adapters" on page 218](#)
- ["Configuring and Managing Ethernet PCIe Adapters" on page 194](#)

### NIC Teaming Utility Fails When an I/O Module Is Offline

The NIC Teaming utility fails if one of the I/O modules is offline and you try to examine details on a team that has missing Ethernet PCIe adapters. The utility also fails if you physically remove an adapter from the system before using the utility to remove the adapter from its team.

Use the NIC Teaming utility only when both partnered I/O modules are online, and close the utility if you need to remove an I/O module for maintenance.

If you need to physically remove or replace an adapter, follow the instructions in ["Physically Replacing Removed Adapters" on page 216](#).

If you have already physically removed an adapter and the NIC Teaming utility is failing, you can recover access to the utility as follows:

#### Removing a missing adapter from a team

1. Close the NIC Teaming utility.
2. Use the instructions in ["II. Displaying the Current Configuration of Ethernet PCIe Adapters" on page 206](#) to determine the slot location and adapter name (Ethernet *nn* or IOx/*n-n*) of the Ethernet PCIe adapter that you physically removed.
3. In Windows PowerShell, run the following command to display information about the teams and their team members:

```
PS> Get-NetLbfoTeam
Name                : EMBEDDED-1
Members             : {Ethernet 12, Ethernet 4}
TeamNics            : EMBEDDED-1
TeamingMode         : SwitchIndependent
LoadBalancingAlgorithm : Dynamic
Status              : Up

Name                : EMBEDDED-2
Members             : {Ethernet 5, Ethernet 7}
```

```
TeamNics           : EMBEDDED-2
TeamingMode        : SwitchIndependent
LoadBalancingAlgorithm : Dynamic
Status             : Up
```

4. Run a command similar to the following to remove the adapter from the team. Use the information you collected in steps 2-3 to specify the name of the adapter (*NIC-Name*) that you physically removed and the name of the team (*Team-Name*) from which to remove the adapter:

```
PS> Remove-NetLbfoTeamMember -Name NIC-Name -Team Team-Name
```

For example, to remove the adapter Ethernet 4 listed in step 3, you would enter:

```
PS> Remove-NetLbfoTeamMember -Name "Ethernet 4" -Team EMBEDDED-1
```

5. After removing the adapter, start the NIC Teaming utility and verify that it is working.
6. If applicable, add a new adapter as soon as possible to ensure the fault-tolerant operation of your system. See ["Adding Ethernet PCIe Adapters to a Team" on page 217](#).

#### Related Topics

- ["Troubleshooting Ethernet Teams and Ethernet PCIe Adapters" on page 218](#)
- ["Configuring and Managing Ethernet PCIe Adapters" on page 194](#)

### NIC Teaming Utility Fails If the Host Name Changes

The NIC teaming utility fails if the host name of the system changes, because the utility attempts to connect to the old host name.

To recover the NIC Teaming utility, start it from the command line with the `/ResetConfig` option. For example:

```
C:\> lbfoadmin.exe /ResetConfig
```

The `/ResetConfig` option resets the list of servers associated with the NIC Teaming utility, which prevents the utility from searching for the previous host name. Resetting the list of servers does not change your team configuration, nor does it disrupt your network connections.

#### Related Topics

- ["Troubleshooting Ethernet Teams and Ethernet PCIe Adapters" on page 218](#)
- ["Configuring and Managing Ethernet PCIe Adapters" on page 194](#)

## Updating Network IP Configuration Settings

Use the network configuration script (`net_config.sh`) if you need to update the network settings for the ztC Endurance system after the initial software installation. For example, you might need to change the network settings if you prepared a system with settings for an end user, but then you need to update the network settings to deploy the system on a different network or subnet, possibly at a new location.

The network configuration script updates network settings for the:

- Baseboard management controllers (BMCs)
- Standby OS of each compute module
- Windows host/EMBEDDED-2 team
- Two Windows Management interfaces for the ztC Endurance console

### Notices:



1. When you run the network configuration script, it restarts the active compute module twice to complete all of the changes. Because you temporarily lose access to your applications, ensure that you run the script only on a non-production system or during a planned maintenance period.
2. Do not run the network configuration script over a connection that the script may change. For example, do not run the network configuration script, which changes the standby IP settings, from a connection that relies on the current IP settings.

### Notes:



1. If you are preparing for the initial software installation, use the BMC configuration script (`bmc_config.sh`) or the software installation script (`install.sh`) to configure the network settings instead of using the network configuration script. See the instructions in "Performing a Full System Software Installation" on page 167.
2. If you are connected to the console of the compute module through the BMC Web console, you will lose your connection if you change the BMC network settings. You need to reconnect to the new addresses you entered in the script or configuration file.
3. You need to provide the location of the Windows ISO image in the script or configuration file because the script needs access to software libraries in the ISO to change the Windows network settings.

If you want to create a file that already contains the new network settings needed for the network configuration script, see "[III. Create the Installation Configuration File \(Optional\)](#)" on page 169. You can specify this file for input when running the network configuration script, BMC configuration script, or software installation script.

Network configuration script usage:

```
Usage : net_config.sh {options}
```

Options:

```
-h           prints this menu
-u url       url with ISO image location
-f filename  path to ISO image
-y filename  path to configuration yaml file
```

### To update the system network settings

1. Optionally, create a file that already contains the configuration settings as described in "[III. Create the Installation Configuration File \(Optional\)](#)" on page 169; otherwise, be prepared to manually enter the information you wrote down in the "[Password and Installation Settings Printable Worksheet](#)" on page 161.
2. Before you run the network configuration script, make sure that the BMC is properly configured. To do this, run `bmc_config.sh` after performing **one** of the following actions:
  - If you are using a physical connection, make sure the VGA cable from the monitor is connected to the VGA port on (preferably) compute module B.
  - If you are not using a physical connection, use SSH (or a similar program) to connect to the Standby OS.
3. Log on to the Standby OS of either compute module as the `zenadmin` user.
4. Start the network configuration script by running **one** of the following commands:



**Note:** To use privileged commands in the `zenadmin` account, you need to add the `sudo` directive.

- If you created the configuration file: `sudo /opt/stratus/bin/net_config.sh -y /opt/stratus/install/zen_config.yaml`

(In the preceding command, if you installed `zen_config.yaml` in a different directory, specify that directory instead.)

- If you did not create the configuration file and want to respond to prompts for each setting:  
`sudo /opt/stratus/bin/net_config.sh {options}`
5. The configuration script loads any existing settings from the installation configuration file and begins prompting for input.



**Notice:** When the script prompts you to configure the BMC, enter N.



**Note:** If you already entered the settings into the installation configuration file, the network configuration script prompts only for the settings you have not entered.

6. Type the current zenadmin password and press `Enter` to continue.
7. Type the Windows Administrator password and press `Enter` to continue.
8. The script prompts for the IP configuration settings for the BMCs, the Standby OS, and the Windows host. Type new values for the settings you need to change and press `Enter` to continue. To accept an existing value, leave the field blank and press `Enter`. Repeat until the script displays **Confirm input below**.
9. The script displays a summary of the settings you entered and prompts you to apply the settings or prompt for each setting again to make any corrections. Do one of the following:
  - To accept the settings that you entered and apply them to the system, type `y` and press `Enter`.
  - To display each prompt again with passwords hidden, type `h` and press `Enter`. For each prompt, type any changes and press `Enter` to continue.
  - To display each prompt again with passwords in clear text, type `unhide`. For each prompt, type any changes and press `Enter` to continue.
10. The configuration script begins to implement the network settings that you specified. View the output to confirm that the changes are successful.
11. The current login session to the Standby OS automatically disconnects so that the system can change the network settings for the compute module.
12. After the system restarts, verify that the BMCs, the Standby OS, and the Windows host are functioning properly.

## Related Topics

- ["Post-Installation Tasks" on page 184](#)

## Configuring Windows Components

After you are finished performing the "Post-Installation Tasks" on page 184, you can configure the Windows host.

If you initialized and mirrored any internal data disks during the installation process, you can create volumes on them now, as summarized in "Adding and Mirroring Data Disks" on page 193.

If you need to configure additional network connections, you can configure adapter teams as summarized in "Configuring Network Interfaces" on page 188.

## Installing Windows Updates

This topic provides important information about installing Windows updates (including Windows Knowledge Base (KB) updates) and hotfixes. (These updates are also referred to as *patches* and *roll ups*).

To view the latest release of Windows updates and hotfixes that Penguin Solutions has tested, see [Patch Release Updates](#).

### Notices:



1. Do not attempt to install any Windows updates without first checking with Penguin Solutions Customer Service. Some Windows updates may not be validated by Stratus.
2. Do not apply security patches to the Ubuntu-based Standby OS, as patching of the Standby OS could cause operational problems and interfere with future software upgrades. Stratus will release updates of the Standby OS as part of ztC Endurance software upgrades.

### Notes:



1. A Windows update requires a system reboot.
2. To learn what the last tested update was, contact Penguin Solutions Customer Service.
3. Be sure to install any necessary Windows updates **after** you enable language support. Otherwise, the language-pack installation may overwrite some Windows updates.

## To install necessary Windows updates

1. From **Windows Settings**, enable **Windows Update** in the **Update & Security** settings.
2. Perform **one** of the following options:
  - Click **Check for updates** to download and install the most recent updates available from Microsoft.
  - Download and manually install the specific update packages from <https://www.catalog.update.microsoft.com/home.aspx>.
3. After the updates are installed, a reboot is required. Choose **one** of the following options:
  - Automatic restart during non-work hours (default)
  - Restart now (recommended)
  - Schedule a restart (alternate recommendation)



**Notice:** The **Disable automatic updates** policy remains in effect after updates are installed.

## Enabling ASNConnect

ASNConnect by BeyondTrust is a third-party remote access solution that allows Penguin Solutions Customer Service to remotely connect to various components of a zTC Endurance system for assistance with diagnostics, troubleshooting, and service/support activities.

ASNConnect allows Penguin Solutions Customer Service to connect remotely to the following:

- On BMC A: the SSH interface and the BMC Web console
- On BMC B: the SSH interface and the BMC Web console
- On the Windows host: the Windows desktop, the file transfer interface, and the zTC Endurance console
- On the standby compute module: the SSH interface

To use ASNConnect, you must install software on your zTC Endurance system.

## Checking Your Connection to ASNConnect

Before you install ASNConnect on your zTC Endurance system, open Windows PowerShell and use the `curl` command to make sure that your zTC Endurance system can connect to **asnconnect.stratus.com** over TCP port 443. The following example shows a successful connection.

```
curl -v asnconnect.stratus.com:443
* About to connect() to asnconnect.stratus.com port 443 (#0)
*   Trying 3.145.54.234...
* Connected to asnconnect.stratus.com (3.145.54.234) port 443 (#0)
> GET / HTTP/1.1
> User-Agent: curl/7.29.0
> Host: asnconnect.stratus.com:443
> Accept: */*
>
* Empty reply from server
* Connection #0 to host asnconnect.stratus.com left intact
```

## Installing ASNConnect on the ztC Endurance System



**Note:** You must complete the license registration for your system before attempting to install ASNConnect. See "Registering the System" on page 254 for more information.

1. [Log in to the ztC Endurance console](#).
2. In the left-hand navigation panel, click **Support Configuration** under **Remote Support**.
3. Click the check box next to **Enable Remote Support Access**. This automatically installs ASNConnect and enables it on Standby B.
4. Click **Save** (or click **Cancel** to restore the previously saved values).



**Note:** After the installation is complete, perform a Smart Exchange to auto-install and enable ASNConnect on Standby A. See "Using Maintenance Mode" on page 250 for more information.

Your ztC Endurance system is now ready to use ASNConnect.

### Related Topics

- "Post-Installation Tasks" on page 184
- "ztC Endurance Console" on page 235
- "Configuring Remote Support Settings" on page 267

## Installing a Custom Security Certificate

The ztC Endurance management server automatically initializes itself with a self-signed SSL certificate, allowing communications to the management server to be encrypted without the identity of

the certificate holder being verified by a third party. To view details of this certificate, click the warning icon on the left side of the browser's address bar.

If you prefer to install a custom certificate on the server, run the `cert_installer.exe` command. You can also use this command to revert to the default certificate or to display the current certificate.

The `cert_installer.exe` command is located in `C:\Program Files\Stratus\bin` and must be run as Administrator. The installer requires a key file containing the private key in addition to the certificate file. Both files must have the `.pem` format.

Command usage:

```
C:\Program Files\Stratus\bin\cert_installer.exe
```

```
To Install/recover/display the Certificate:
```

```
Usage: cert_installer.exe [Option]
```

```
-d    displays current certificate
```

```
-r    recovers to default certificate
```

```
-c    [PATH to certificate.pem] -k [PATH to key.pem], installs the customer cer-  
tificate
```

```
-h    displays help
```



**Note:** The `cert_installer.exe` command automatically restarts the management server after any operation that changes the certificate, so you do not need to perform a manual restart after installation.

### To install a custom certificate

1. Copy your new, valid certificate and key `.pem` files from `C:\Program Files\Stratus\bin` to the Administrator home directory on the ztC Endurance system (for example, `C:\Users\Administrator\Desktop\joseph`).
2. Issue the following command from Windows PowerShell to install the certificate:

```
PS C:\Users\Administrator\Desktop\joseph\cert_installer.exe -c  
C:\Users\Administrator\Desktop\joseph\cert.pem -k  
C:\Users\Administrator\Desktop\joseph\key.pem
```

### To revert to the default certificate

```
PS C:\Users\Administrator\Desktop\joseph\cert_installer.exe -r
```

## To display information about the currently used certificate

PS C:\Users\Administrator\Desktop\joseph\cert\_installer.exe -d

## Changing Passwords on a ztC Endurance System

A ztC Endurance system requires four sets of passwords:

- BMC Web console password for the Administrator user account
- zenadmin password on the Standby OS
- Windows Administrator password
- ztC Endurance console and REST API password

This topic describes these passwords and explains how to update them (when possible) after the installation. See "[Gathering Information](#)" on page 148 to learn more about these passwords.

### BMC Web Console Password for the Administrator User Account



**Note:** This procedure assumes that the current BMC Web Console passwords for BMC A and BMC B are identical.

#### To change the BMC Web console administrator account (admin) password:

1. Log in to Windows PowerShell as a user with Administrator rights.
2. Stop the following services:
  - Stratus Management Monitor Service
  - Stratus Management Service
3. Log in to the BMC Web console for BMC A, as described in "[Logging In to the BMC Web Console](#)" on page 273.
4. In the side panel, click **Settings**, then click **User Management** in the main display. The **User Management** page appears.
5. On the **User Management** page, select **Channel 1** from the **Channel** pulldown menu.
6. Click to select the profile labeled **admin/Administrator**. The **User Management Configuration** page specific to the **admin/Administrator** profile appears.
7. In the **Logged-In Password** field, enter the current password.
8. Enable the **Change Password** checkbox.

9. In the **Password** and **Confirm Password** fields, enter the new password.



**Note:** Both BMCs must have an account with the username `admin`, and both BMCs must use the same administrator password.

10. Under **Enable Channel Access**, ensure that Channel 1, Channel 2, Channel 7, and Channel 8 are all selected.
11. Scroll down and click **Save**.
12. Repeat steps 3 through 11 on BMC B.
13. Notify the system-management software as described in the following instructions.



**Notice:** The system-management software uses the same password for IPMI accesses to the BMC. Therefore, if you do not notify the system-management software of a password change, any attempts to access the BMC by the system-management software results in a failure.

#### To notify the system-management software

1. Log in to Windows Server and launch PowerShell as a user with Administrator rights.
2. At the command prompt, cd to `C:\Program Files\Stratus\bin\`.
3. Run the following command:

```
.\cfgpasswd.exe --bmcadmin
```



**Note:** Incorrect use of the `cfgpasswd` command can result in inconsistent BMC Web console passwords.



**Note:** The `cfgpasswd` command does not change the password; rather, it notifies the system-management software of the change.

4. At the prompts, enter the new BMC administrator password that you created in the BMC Web console.

The following example shows how to use the `cfgpasswd` command.

```
PS c:\Program Files\Stratus\bin>.\cfgpasswd.exe --bmcadmin
Enter value for BMC admin password: xxxxxxxx
Confirm value for BMC admin password: xxxxxxxx
Updated BMC admin password
Installed new C:\Program Files\Stratus\install\install-config.json
Changes will be applied to sra-mgmt config at next service start.
Configured password for zenadmin account is correct on current
Standby server.
PS c:\Program Files\Stratus\bin>
```

5. Restart management services and verify access as described in the following instructions.

**To restart management services and verify access:**

1. Start the following services:
  - Stratus Management Monitor Service
  - Stratus Management Service
2. Wait for five minutes.
3. Log in to the BMC Web console for both BMC A and BMC B, as described in "[Logging In to the BMC Web Console](#)" on page 273, and verify that you are able to log in as an Administrator with the new password.

## zenadmin Password

The system-management software uses the Ubuntu operating system zenadmin account on the Standby OS for BeyondTrust installation and configuration, support logs, and software upgrades.



**Notice:** Both Standby OSes require the same password for the zenadmin account.

### To change the zenadmin account password

1. Change the password for each Ubuntu instance with the Linux `passwd` command:
  - a. From the Windows host or a management PC, use the `ssh` command to connect to each Standby OS (for example, `ssh username@hostname`). Note that you must perform a Smart Exchange to connect to each Standby OS.
  - b. Change the password with the Linux `passwd` command:

```
/usr/bin/passwd zenadmin
```
2. Notify system management about the new password created in the previous steps:
  - a. From the Windows Host, in Windows PowerShell, run the following command:

```
& 'C:\Program Files\Stratus\bin\cfgpasswd.exe' --zenadmin
```
  - b. At the prompt, enter the new password.



**Note:** The `cfgpassword` command does not change passwords. It simply stores an encrypted copy of the password for the management software to use when it needs to access the account protected by the password.

3. Verify the password on the current Standby OS by running the following command on the Windows host:

```
& 'C:\Program Files\Stratus\bin\cfgpasswd.exe' --verify
```

## Windows Administrator Password

For information about changing the Windows Administrator password, see the Windows documentation provided on the Microsoft website.



**Note:** ztC Endurance does not use the Windows Administrator password, but does check its complexity during network configuration. For this reason, the Windows Administrator password must also meet the password requirements described in the "Password Settings" on page 149 table.

## ztC Endurance Console Passwords

To change ztC Endurance console usernames and passwords, use the ztC Endurance console as described in ["Managing User Accounts" on page 259](#).

The REST API uses the same usernames and passwords.



**Notice:** If you change the usernames and passwords, any external application using the REST API must change its usernames and passwords to match.



# 9

## Chapter 9: Using the ztC Endurance Console

The ztC Endurance console is a browser-based interface that provides management and monitoring of a ztC Endurance system from a remote management computer. For an overview of the console and for links to each of the pages within the ztC Endurance console, see ["ztC Endurance Console" on page 235](#).

### ztC Endurance Console

The ztC Endurance console is a browser-based interface that provides management and monitoring of a ztC Endurance system from a remote management computer. You can perform many administrative operations from the console because it provides access to the system as a whole as well as to individual modules, components of modules, and other resources.

For information on the requirements of the remote management computer that runs the ztC Endurance console, see ["ztC Endurance Console Requirements" on page 236](#).

Using the options listed in the left pane of the ztC Endurance console, you can perform a variety of administrative functions:

- Read system alerts from the Dashboard. See ["Dashboard Page" on page 241](#).
- Configure the mail server. See ["Configuring the Mail Server" on page 243](#).
- View information about the system and its components. See ["Hardware Page" on page 245](#).
- Monitor resources for volumes, including their state, name, data synchronization status, and size. See ["Volumes Page" on page 253](#).
- Specify the name and contact information for an administrator or owner of the system. See ["Specifying Owner Information" on page 254](#).
- Register your system. See ["Registering the System" on page 254](#).

- Configure users. See ["Configuring Users" on page 258](#).
- View alerts. See ["Alert History Page" on page 261](#).
- View support logs. See ["Support Logs Page" on page 262](#).
- Configuring notifications. See ["Configuring e-Alerts" on page 263](#) and ["Configuring SNMP Settings" on page 265](#).
- Configure remote support settings to send alerts to Penguin Solutions Customer Service via the Active Service Network (ASN) when an event requires attention. See ["Configuring Remote Support Settings" on page 267](#).
- Configure proxy settings to support notification messaging and remote support access features. See ["Configuring Internet Proxy Settings" on page 269](#).

In addition, you can use the ztC Endurance console to:

- Edit your user information. See ["Editing Your User Information" on page 240](#).
- View your system's serial number by hovering the cursor over the ztC Endurance model number at the top of the left pane.
- View the management IP addresses, the system's software version number, and asset ID in the banner at the top of the ztC Endurance console.

## Related Topics

- ["Logging In to the ztC Endurance Console for the First Time" on page 237](#)
- ["Logging In to the ztC Endurance Console" on page 238](#)
- ["Using the ztC Endurance Console" on page 235](#)

## ztC Endurance Console Requirements

The ztC Endurance console provides browser-based remote management of the ztC Endurance system, including its processing, storage, networks, and power.



**Note:** The ztC Endurance console manages the base ztC Endurance system. For Windows-specific functions, use Windows tools such as Windows PowerShell.

- Locate the two ztC Endurance console IP addresses returned at the end of the Windows installation. (See ["Performing a Full System Software Installation" on page 167](#).) You use one of these IP addresses to log in to the ztC Endurance console.
- Your computer must be able to access the subnet containing the ztC Endurance management network, which is enabled on the port labeled **1G MGMT**. See [Figure 1-4](#) for the location of this

port.

- Use a supported browser. See ["Compatible Internet Browsers" on page 237](#).

### Related Topics

- ["ztC Endurance Console" on page 235](#)
- ["Using the ztC Endurance Console" on page 235](#)

## Compatible Internet Browsers

A browser is used to connect to the ztC Endurance console. Use only browsers that are compatible with ztC Endurance systems. Using an incompatible browser can result in some rendering problems and the omission of some wizards.

[Table 9-1](#) lists browsers that are compatible with ztC Endurance systems.

**Table 9-1: Compatible Browsers**

Compatible Browsers	Release
Microsoft Edge	118 or later
Mozilla® Firefox®	118 or later
Google® Chrome™	118 or later

## Logging In to the ztC Endurance Console for the First Time



**Note:** If this is **not** your first time logging in to the ztC Endurance console, see ["Logging In to the ztC Endurance Console" on page 238](#) instead.

When deploying the system, log in to the ztC Endurance console to change the default password.

### To log in to the ztC Endurance console for the first time

1. From a networked PC or laptop, type the secure version (**https**) of one of the two management IP addresses of your ztC Endurance system into a browser address bar.



**Note:** If a security message appears, proceed to the web site. You can add a security exception later, to allow the site to load without the message "Configuring Secure Connections."

2. The login page of the ztC Endurance console appears. Enter **admin** for the **Username** and **admin** for the **Password** (or other credentials, if provided), and then click **LOGIN**.
3. When you see the **Warning** message notifying you to change your password, click **OK**.



**Notice:** You must change the password for **admin** now, for security purposes. You can change it again later when you update the default user profile for the **admin** account. You make these changes on the **Users** page (see ["Configuring Users" on page 258](#)).

4. On the **Change Password** window, provide the requested password information and click **Continue**. The password must conform to the system's password policy (for information, see [Password Policy](#)).
5. When you see a message saying that your password reset was successful, click **Finish**.
6. When the login page appears, enter **admin** for the **Username** and your new password, and then click **LOGIN**.

The ztC Endurance console appears and the initial login is complete. Bookmark or otherwise make note of the system IP address for use when logging in to the console in the future.

Perform additional tasks in ["Post-Installation Tasks" on page 184](#), if necessary.

### Related Topics

- ["Logging In to the ztC Endurance Console" on page 238](#)
- ["ztC Endurance Console" on page 235](#)

### Logging In to the ztC Endurance Console



**Note:** If this is your first time logging in to the ztC Endurance console, see ["Logging In to the ztC Endurance Console for the First Time" on page 237](#) instead.

Log in to the ztC Endurance console to manage the ztC Endurance system. Using the console, you can manage the system, including its processing, storage, networks, and power. You can also view alerts and perform other administrative tasks.

**Notes:**

1. A login session times out after 10 minutes, if unused.
2. The system has a limit of 10 login sessions.
3. A username cannot start with a special character and is limited to 64 characters.
4. Passwords must conform to the system's "Password Policy" on page 240.

**To log in to the ztC Endurance console**

1. Type one of the two management IP addresses of your ztC Endurance system or the fully qualified domain name (FQDN) into a browser address bar:

`https://IP_address`

OR

`https://FQDN_name`

2. When the login page appears, enter your **Username** and **Password**.

If you have forgotten your password, click **Forgot Password?** and the **Reset Password** page appears. Enter the requested information to reset your password.



**Note:** Resetting a password requires that you have an email account on the system, with an email address, as configured in your user account (see "Managing User Accounts" on page 259). If you are unable to receive email, contact your system administrator.

**To reset your password**

**Note:** To receive email when resetting your password, the mail server must be configured. See "Configuring the Mail Server" on page 243.

- a. When the **Reset Password** page appears, enter your **Username** and click **Continue**. An email is sent to the email address listed with your local user account. The email contains a link to a reset password page.
- b. In your email account, open the email with the reset-password link, and click the link. The **Reset Password** page reappears.

- c. For **New Password** and **Confirm Password**, type your new password. The new password must conform to the system's ["Password Policy" on page 240](#).

Click **Continue**.

- d. A page appears, with a message that the reset was successful and that you can log in to the system with your new password. Click **Finish**.

3. Click **LOGIN**.

## Password Policy

The system's password policy requires that your password meet these conditions:

- Its minimum length is 8 characters, and its maximum length is 72 bytes.
- It must contain both upper- and lowercase characters.

## Related Topics

- ["Logging In to the ztC Endurance Console for the First Time" on page 237](#)
- ["ztC Endurance Console" on page 235](#)

## Editing Your User Information

Edit your user information (that is, your user profile) by changing your user name, email address, first name, last name, or password.

### To edit your user information

1. Click your user name in the upper right-hand corner of the console.

The **Edit User** dialog box opens.

2. Enter or modify values for the following:
  - **User Name**
  - **Email Address**
  - **First Name** (optional)
  - **Last Name** (optional)
  - **Password**



**Note:** Passwords must confirm to the system's "Password Policy" on page 240.

- **Confirm Password**

3. Click **Save**. (Or click **Cancel** to cancel the changes.)

### Related Topics

- ["ztC Endurance Console" on page 235](#)

## Dashboard Page

The **Dashboard** page:

- Displays a summary of outstanding alerts on the ztC Endurance system.
- Allows you to perform a total system shutdown by clicking the **Shutdown** button.



**Notice:** Do not click the **Shutdown** button unless you are familiar with the topics discussed in ["System Power" on page 82](#).

The **Dashboard** page opens when you log in to the ztC Endurance console. To open it from other pages, in the left-hand navigation panel, click **Dashboard** under **System**.

On the **Dashboard** page:

- The masthead at the top of the page displays registration status information, system-alert status, the name of the current user, and the **Logout** option.
- Below the masthead, the ztC Endurance model number appears. To view your system's serial number, hover the cursor over the ztC Endurance model number. The system hostname, the management IP address of compute module A, the management address of compute module B, the software version number, and the asset ID also appear below the masthead, along with the **Shutdown** button and a **Help** button that launches the documentation for your version of ztC Endurance in a browser window.
- The bottom pane displays a list of alerts associated with the components shown in the system diagram.
- The left-hand navigation panel displays the pages that allow you to configure or view information about the system. You can also hover over the model name at the top of the navigation panel to view the system's serial number.

To display additional information about outstanding alerts, click an alert symbol (for example, ) in the system diagram, or click an entry in the list of alerts below the system diagram. Alert lists may appear

in tabs such as **All**, **System**, and **Ignored**, as well as in tabs for each component shown in the system diagram. These tabs may appear below the system diagram, depending on the alerts. The alert information includes:

- The component associated with the issue (for example, the ztC Endurance system or a module).
- A description of the activity or task that requires attention.
- The ability to ignore the issue (only if **Ignore** appears in the **Action** column). You can restore the alert by clicking the **Ignored** tab and then clicking **Restore** in the **Action** column for the alert.
- The reason the issue should be resolved by clicking the row with the alert. The information will appear in the **Information** column.

Resolve active alerts as soon as possible (see ["Resolving Outstanding Alerts on the Dashboard" on page 243](#)).

## Understanding the ztC Endurance System Diagram

The system diagram displays a graphical representation of system status. A star symbol (★) indicates the active module.

The system diagram also shows which disk-drive slots and PCIe-card slots are populated. If a disk-drive slot is grayed-out in the diagram, that slot is empty. Similarly, if the diagram shows a PCIe-card slot with slot covers instead of a PCIe card with ports, that slot is empty.

Alert symbols, if present, represent informational or critical alerts that require attention. Click an alert symbol to display information about the alert.





## Alert Symbols

General alert symbols, in descending order of severity, are:

- Critical or Serious (🚨)
- Moderate (😬)
- Minor (⚠️)
- Informational (ℹ️)
- Good (✅)

Device-specific alert symbols include:

- PSU symbols:
  - ️ ⚡: Reports an alert on a failing or degraded PSU
  - ️ ⚡: Reports a warning alert on a PSU (for example, if the PSU is simplex)

- Disk symbols:
  - : Reports an alert on a failing or degraded physical disk
  - : Reports a warning alert on a physical disk (for example, if the disk is simplex)
- Network symbols:
  - : Reports an alert on a failing or degraded teamed network port.
  - : Reports a warning alert on a teamed network port (for example, if the network port is simplex)

### Related Topics

- ["ztC Endurance Console" on page 235](#)

## Resolving Outstanding Alerts on the Dashboard

Resolve any outstanding alerts that appear on the **Dashboard** page.

### To resolve outstanding alerts

If an alert appears in the ztC Endurance system diagram on the ztC Endurance console **Dashboard** page, click the alert. Information about it appears in the bottom pane. Your options are as follows:

- Resolve the alert.

For instance, if you see a message similar to **Support Notification service should be enabled to ensure the best possible customer support**, enable the support notification service. See ["Configuring Remote Support Settings" on page 267](#).
- For minor alerts, click **Ignore** (beneath the **Action** column) to ignore the alert and remove it from the list. Clicking **Ignore** hides the alert. You cannot ignore more serious alerts.

To restore the ignored alert to the list, click the **Ignored** tab above the alerts list, and then click **Restore**, under the **Action** column.

### Related Topics

- ["ztC Endurance Console" on page 235](#)
- ["Dashboard Page" on page 241](#)
- ["Configuring e-Alerts" on page 263](#)

## Configuring the Mail Server

Configure the mail server to enable the ztC Endurance system to send email when, for example, a user needs to reset a password, generate a test alert, or receive alerts via email (e-Alerts).

## To configure the mail server



**Note:** If you change any mail-server settings, you **must** re-enter the mail-server password if authentication is enabled.

1. In the left-hand navigation panel, click **Mail Server Configuration** under **System**.
2. On the **Mail Server Configuration** page, click the **Enable Mail Server** box. Boxes for specifying or selecting the following settings appear:
  - **SMTP Server** (required)—Enter the name of the Simple Mail Transfer Protocol (SMTP) server that your company uses to send email.
  - **Port Number**—Enter the port number to use when sending e-Alerts. If no port number is specified, the default SMTP port 25 is used.
  - **Sender's Email Address**—Enable e-Alert delivery by specifying a valid sender's email address in either of the following cases:
    - You have not specified a DNS server on the ztC Endurance system **and** your SMTP server is not configured to accept domain literals (From addresses in the form `noreply@IP_address`).
    - You want the e-Alert to provide a different sender's email address (for example, `noreply@company.com`).

Any email address that the SMTP server accepts is sufficient.

- **Encrypted Connection**—Select a value from the drop-down menu for the encryption protocol that the SMTP server requires:



**Note:** Regardless of whether you select **TLS** or **SSL**, the ztC Endurance software selects whichever protocol is best at the time of the connection.

- **None** for no encryption. By default, port number 25 is used.
- **TLS** for the Transport Layer Security (TLS) protocol. For TLS, you should specify 587 for **Port Number**, though 25 is used by default. However, check with your network administrator to make sure that 587 is the correct port number.
- **SSL** for the Secure Sockets Layer (SSL) protocol. For SSL, you should specify 465 for **Port Number**, though 25 is used by default. However, check with your network administrator to make sure that 465 is the correct port number.

- **Enable Authentication**—Click this box if the SMTP server requires authentication to send email. Then, type the **Username** and **Password** for the SMTP account.



**Note:** If authentication is enabled (because the **Enable Authentication** box is already checked or because you have just checked it) and you change any mail server settings, you **must** re-enter the mail-server password.

3. Click **Save** (or click **Cancel** to restore the previously-saved values).

## Related Topics

- ["ztC Endurance Console" on page 235](#)

## Hardware Page

The **Hardware** page displays information about the hardware components of a ztC Endurance system. The top pane lists the state, activity type, name, and serial number of each compute module, I/O module, storage module, and PSU in the system. The bottom pane displays detailed information about the top-pane component that is currently selected.

When you select tabs in the bottom pane, the information displayed is generally self-explanatory. However, additional information about the [Memory](#), [Network](#), [Fibre Channel](#), and [Storage](#) tabs is provided later in this section.

In addition to viewing information about hardware components, you can use the **Hardware** page to do the following:

- Identify a hardware component by clicking a button to flash its ID LED (see ["Identifying a System or Component" on page 250](#)).
- Place a compute module into maintenance mode, shut it down, and then return it to service (see ["Using Maintenance Mode on Compute Modules" on page 251](#)).
- Go to the BMC login page. From the compute module's **BMC** tab, click an IP address to go to the BMC login page (see ["Logging In to the BMC Web Console" on page 273](#)).
- View operating-system information (name, version, IP address, and hostname) by clicking the compute module's **OS** tab.

## Hardware States

The **State** values show the severity of the component's state. Values are:

- Informational (Page 245 of 304

- Minor, warning, or inconsistent state (⚠️): User attention recommended.
- Moderate state (⚠️): Module is simplex; user attention required.
- Broken, failed, or severe state (❌): Component not operational; user attention required. **Activity** text may provide additional information about this state.
- Syncing (🔄): Component is working to become redundant again or the compute module is performing a Smart Exchange.
- Maintenance mode (🔧): Component is in maintenance mode. See ["Using Maintenance Mode" on page 250](#).

## Hardware Activity Types

The **Activity** values show the component's current activity type. Values are:

- **Running** (▶️): Component provides an operating environment and is running normally. This value applies only to the active or standby compute module.
- **Connected** (🔌): Component is actively connected to the active compute module and is operating normally. This value applies to storage modules, I/O modules, and PSUs.
- **Shutting Down** (❌): Compute module is shutting down. See ["Shutting Down and Restarting a Compute Module" on page 252](#).
- **Shutdown** (❌): Compute module has shut down.
- **Smart Exchange** (🔄): Active compute module is performing a Smart Exchange to the other compute module.
- **Recovering** (⌛): Compute module is transitioning.
- **Booting** (⌛): Compute module is booting.
- **Failed** (❌): Component has failed and is not operational.
- **Disconnected** (❌): Component is not connected to the active compute module.
- **Off** (🔌): Component is powered off.

## To learn more about the Memory tab

On the **Hardware** page, you can learn more about a specific compute module's memory by selecting the compute module and then clicking its **Memory** tab in the lower pane. The **Memory** columns have the following meanings:

- **State:** Displays the state of the DIMM. For example, a green checkmark in the **State** column indicates that the DIMM's state is good. See ["Hardware States" on page 245](#) for more information about the hardware states and their associated icons.
- **Name:** Displays the name of the DIMM (for example, **DIMM8**).
- **Slot:** Displays which of the two DIMM slots on a channel an DIMM is physically plugged in to. Because ztC Endurance systems implement only one slot per channel, you can ignore the values in this column.
- **Socket:** Displays the processor to which an DIMM is connected. For example, a value of 1 indicates that the DIMM is connected to processor 1.
- **Channel:** Indicates the number of the channel (that is, a physical set of wires) between the processor and the DIMMs. Each processor in a ztC Endurance system has 8 DIMM channels.
- **Capacity:** Displays the size of the DIMM, in gigabytes (for example, **32 GB**).

See ["Memory in ztC Endurance Systems" on page 22](#) for more information about DIMMs.

### To learn more about the Network tab

On the **Hardware** page, you can learn more about a system's Ethernet PCIe adapters.

- To learn about a specific compute module's embedded Ethernet PCIe adapters, select the compute module and then click its **Network** tab in the lower pane.
- To learn about a specific I/O module's Ethernet PCIe adapters, select the I/O module and then click its **Network** tab in the lower pane.

The **Network** columns have the following meanings (note that a value of **Empty** indicates that the associated slot is empty):

- **State:** Displays the state of the component. For example, a green checkmark in the **State** column indicates that the PCIe adapter's state is good. See ["Hardware States" on page 245](#) for more information about the hardware states and their associated icons.
- **Location:** Displays the location of the component. For example, in a compute module, **embedded-A** means that the embedded PCIe adapter is located in PCIe slot A. In an I/O module, **slot B/2** means that the PCIe adapter is located in I/O module B, slot 2 (see ["PCIe-Adapter Physical Slot Numbering" on page 31](#)).

- **Name:** Displays the name of the component (for example, **eno1**).
- **Port:** Displays which port the component is connected to (for example, **1**).
- **PCI ID:** Indicates the component's PCIe address identifier on the system (for example, **0000:02:00.0**).
- **Speed:** Indicates the speed of the component (for example, **10 Gbps**).
- **MAC Address:** Displays the component's burned-in MAC address (for example, **0c:48:c6:c7:2c:d6**), not its virtual MAC address.

### To learn more about the Fibre Channel tab

On the **Hardware** page, you can learn more about a system's Fibre Channel (FC) PCIe adapters by selecting the I/O module and then clicking its **Fibre Channel** tab in the lower pane.



**Note:** The **Fibre Channel** tab appears only in systems that contain an FC PCIe adapter.

The **Fibre Channel** columns have the following meanings:

- **State:** Displays the state of the component. For example, a green checkmark in the **State** column indicates that the FC PCIe adapter's state is good. See "[Hardware States](#)" on [page 245](#) for more information about the hardware states and their associated icons.
- **Location:** Displays the location of the component. For example, **slot A/2** means that the FC PCIe adapter is located in I/O module A, slot 2.
- **Name:** Displays the name of the component (for example, **fchba\_cb:00.0**).
- **PCI ID:** Indicates the component's PCIe address identifier on the system (for example, **0000:cb:00.0**).
- **Speed:** Indicates the speed of the component (for example, **32 Gbps**).
- **WW Node Name:** Displays the unique identifier for the component (for example, **20:00:f4:c7:aa:3c:10:80**).
- **WW Port Name:** Displays the unique identifier for the port on the component (for example, **21:00:f4:c7:aa:3c:10:80**).

## To learn more about the Storage tab

On the **Hardware** page, you can learn more about a specific storage module's disks by selecting the storage module and then clicking its **Storage** tab in the lower pane. The **Storage** columns have the following meanings:

- **State:** Displays the state of the disk. For example, a green checkmark in the **State** column indicates that the disk's state is good. See "[Hardware States](#)" on page 245 for more information about the hardware states and their associated icons.
- **Location:** Displays the location of the disk. For example, **slot A/6** indicates that the disk is located in storage module A, slot 6.
- **Name:** Displays the name of the disk (for example, **0000\_0000\_0000\_0001\_00A0\_7523\_4006\_303A**). If the disk slot is empty, **Empty** is displayed.



**Note:** The **Name** value under the **Storage** tab displays a unique "name" assigned by Windows, which is referred to as the Serial Number in the `rdmadm` and Windows terminal interface commands such as `get-disk` and `wmic diskdrive`. This name is different from the serial number that appears on the physical disk's sticker.

- **PCI ID:** Indicates the disk's PCIe address identifier on the system (for example, **0001:74:00.0**).
- **Availability:** Indicates if the disk is **Redundant** (that is, paired with another physical disk). If the disk slot is empty, **Unused** is displayed.
- **Logical ID:** Displays the logical ID of the disk (for example, **RDM 1**). If the disk slot is empty, **Unconfigured** is displayed.

## Related Topics

- ["Removing and Replacing System Components" on page 97](#)
- ["Dashboard Page" on page 241](#)
- ["Disk Drives" on page 27](#)
- ["Memory in ztC Endurance Systems" on page 22](#)
- ["PCIe Adapters" on page 30](#)
- ["System CRU Modules" on page 20](#)
- ["General Servicing Information" on page 97](#)
- ["ztC Endurance Console" on page 235](#)

## Identifying a System or Component

You can identify:

- A specific ztC Endurance system in a cabinet
- A specific component within a ztC Endurance system

### To identify a ztC Endurance system

Press the **ID** button on the compute module (see [Figure 1-5](#)). The blue ID LED on the control-panel ear (see [Figure 4-2](#)) illuminates for 30 seconds.

### To identify a component in a ztC Endurance system

1. In the left-hand navigation panel, click **Hardware** under **System**.
2. In the top pane of the **Hardware** page, select the component that you want to identify and then

click the **Identify** () button. The blue ID LED for that component illuminates for 30 seconds. See ["Status LEDs" on page 86](#) for the location of each component's ID LED.

## Related Topics

- ["Hardware Page" on page 245](#)
- ["Dashboard Page" on page 241](#)
- ["Compute Module" on page 21](#)

## Using Maintenance Mode

If you need to take a compute module offline for service, you place it into maintenance mode.

## Using Maintenance Mode on Compute Modules

When [you place a compute module into maintenance mode](#), it goes offline for service. While a compute module is in maintenance mode, operations such as monitoring, recovery, automatic power-on, and so on cannot occur on that compute module.

If you place the **active** compute module into maintenance mode, the system automatically performs a Smart Exchange.

### What is Smart Exchange?

Smart Exchange is a Stratus proprietary process that maintains system availability and protects against data loss. If the ztC Endurance system detects a degradation or failure within the active compute module, Smart Exchange:

- Automatically activates the standby compute module and copies over in-process data
- Reroutes all I/O and storage connected to the original active compute module over to the newly activated compute module

Smart Exchange occurs while the system is running and except for a very brief pause (usually, less than one second), is undetectable to the operating system and customer applications.

[You must manually remove the compute module from maintenance mode](#) to return it to service.

Note that when the active compute module enters maintenance mode, the standby compute module becomes active after the Smart Exchange completes. During this operation, communications between the active and standby compute modules are disabled, and the operating system and applications running on the original active compute module are migrated to the new active compute module. This protects the operating system and running applications from any potential disruption caused by the operation.

**Notices:**



1. A compute module must be in maintenance mode before you shut it down. For information about shutting down a compute module, see ["Shutting Down and Restarting a Compute Module" on page 252](#).
2. The system is not fault tolerant when a compute module is in maintenance mode. For continuous uptime, finalize service as soon as possible so that the compute module can exit maintenance mode and go back online.

### To place a compute module into maintenance mode

1. From the **Hardware** page, select a compute module.
2. Click **Work On**.
3. Click **Yes** on the **Confirm** window.

When the compute module is in maintenance mode, its state appears as **Maintenance Mode**, and its **Activity** displays as **Running**. At this point, it is safe to [shut down the compute module](#) if necessary.

### To remove a compute module from maintenance mode

1. From the **Hardware** page, select the compute module that is in maintenance mode.
2. Click **Finalize**, which removes the compute module from maintenance mode.

When the compute module exits maintenance mode, its state appears as **Normal**, and its **Activity** displays as **Running**.

### Related Topics

- ["ztC Endurance Console" on page 235](#)
- ["Hardware Page" on page 245](#)

### Shutting Down and Restarting a Compute Module

From the **Hardware** page, you can shut down and restart a compute module. You do this to perform service operations that require physically removing a compute module from the system.

A compute module must be in maintenance mode before you shut it down. For information about entering a compute module into maintenance mode, see ["Using Maintenance Mode" on page 250](#).

### To shut down a compute module

1. From the **Hardware** page, select a compute module that is in maintenance mode.
2. Click **Shutdown**.
3. Click **Yes** on the **Confirm** window.

When the compute module has been shut down, its state appears as **Maintenance Mode**, and its **Activity** displays as **Shutdown**. At this point, it is safe to [remove the compute module](#).

### To restart a compute module

1. From the **Hardware** page, select a stopped compute module.
2. Click **Boot**.
3. Click **Yes** on the **Confirm** window.

After the compute module completes its restart, its state still appears as **Maintenance Mode**, and its **Activity** displays as **Running**.

4. [Remove the compute module from maintenance mode](#).

### Related Topics

- ["ztC Endurance Console" on page 235](#)
- ["Hardware Page" on page 245](#)
- ["Using Maintenance Mode" on page 250](#)
- ["Removing and Replacing a Compute Module" on page 103](#)

### Volumes Page

The **Volumes** page displays information about logical storage volumes created from the physical devices in the storage modules. To open this page, in the left-hand navigation panel, click **Volumes** under **System**.

The **Volumes** page displays the following columns with information about volumes in the top pane:

- State
- Name
- Disk Synchronization. If a volume is synchronizing, this column displays the percentage complete and the estimated time of completion.

- Size
- Mounts

Click the name of a volume in the top pane of the **Volumes** page to display additional information about the volume in the bottom pane. This information includes the physical members of the volume as well as their states.

### Related Topics

- ["Disk Drives" on page 27](#)
- ["ztC Endurance Console" on page 235](#)

## Specifying Owner Information

Specify the name and contact information for an administrator or owner of the ztC Endurance system to make this information available for support purposes. This contact information is included in any email sent by e-Alerts.

This contact information is available in the ztC Endurance console and provided in response to Simple Network Management Protocol (SNMP) requests.



**Note:** The information you specify during Step 1 and Step 2 of the registration portal procedure (see ["Registering the System" on page 254](#)) is automatically supplied as the system owner information on the **Owner Information** page. However, if you have already specified system owner information on the **Owner Information** page and then register your system, the information specified during registration does not overwrite the system owner information.

### To specify system owner information

1. In the left-hand navigation panel, click **Owner Information** under **System**.
2. On the **Owner Information** page, supply information in the **Full Name**, **Phone Number**, **Email Address**, and **Site Address** fields.
3. Click **Save**.

### Related Topics

- ["ztC Endurance Console" on page 235](#)

## Registering the System

Registering a ztC Endurance system:

- Helps Penguin Solutions Customer Service deliver responsive, expedited service, should you contact Penguin Solutions with a potential issue or need a replacement part.
- Registers you for the **Penguin Solutions Customer Service Portal** at <https://support.penguinsolutions.com/csm>, giving you access to technical resources—including Knowledge Base articles, Customer Service publications, and software downloads—that are available only to registered users.

To use these services, it is important to register the system soon after you log in to the ztC Endurance console for the first time. However, you can register the system later. You can do so on a system with or without Internet access.



**Note:** The information you specify during Step 1 and Step 2 of the registration portal procedure is automatically supplied as the system owner information on the **Owner Information** page (see "Specifying Owner Information" on page 254). However, if you have already specified system owner information on the **Owner Information** page and then register your system, the information specified during registration does not overwrite the system owner information.

On a system that does not have Internet access, you need to move a file between the location of the ztC Endurance console (which does not have Internet access) and a location with Internet access. Two possible methods for moving the file follow.

- A USB flash drive—You move a USB flash drive between a management PC (which can connect to the system) and a computer with Internet access.
- A mobile device such as a laptop or smart phone—You move a mobile device between a location where you can log in to the ztC Endurance console and a location with Internet access.



**Prerequisite:** Before you register the system, read [To complete the registration portal steps](#) to ensure that you have all required information.

## To complete the registration portal steps

**Step 1: General Information**—Enter the following information:

- **First Name and Last Name**
- **Company Email**—Provide the email address of the company that is the final deployment site. Do not provide a personal email address.

You also need to review and accept the **Service Terms**.

**Step 2: Location Info**—Enter the following information:

- **End User Company Name**—Provide the full name of the company where the system will be deployed.
- **Deployment Shipping Address**—Provide the complete address for replacement-part shipments. Use the address of the company that is the final deployment site. Do not provide a post-office box. Fields are:
  - **Address 1** and **Address 2**
  - **City, State, Postal Code**, and **Country**
  - **Special Instructions** (for example, "always deliver to loading dock 2")

**Step 3: Contact Details**—Enter the following information:

- **Primary Technical Contact** and **Secondary Technical Contact**—Provide the names of the technical contacts who will be communicating with your authorized Penguin Solutions service representative.
- **Service Renewal Contact**—Provide the name of the person who is responsible for handling annual service-agreement renewals.

For each contact, enter **First Name**, **Last Name**, **Email Address**, **Desk Phone**, and **Mobile (optional)**. You can add more contacts later using the **Penguin Solutions Customer Service Portal** at <https://support.penguinsolutions.com/csm>.

After you click **Next** at the bottom of the page, Penguin Solutions verifies the information.

If there is a problem with the information, a **Problem Encountered** pane appears, which describes the problem. Click **Back** to fix the problem, if possible. If a problem still exists, click **Next** to continue, allowing you to download a file that enables you to complete registration. To help resolve the problem and ensure that your account is set up properly, your authorized Penguin Solutions service representative will contact you.

An **Information Verification** page appears, allowing you to review the information. Click **Back** to change any information. Click **Next** to submit the information and complete registration.

**Step 4: License Key**—For a system with Internet access, check the **License** page of the ztC Endurance console to confirm that the license has been installed. For a system without Internet access, click **Download License** to download the license-key file, which you will install on the ztC Endurance system. Make note of the location where you download the file.

**To register a system and acquire a license**

## On a system with Internet access

1. In the ztC Endurance console, do one of the following:
  - a. Click **License**, under **System**, in the left-hand navigation panel.
  - b. Click **Register for License** in the masthead.
2. For **Online License Registration and Activation**, click **Register Online** to open a new browser tab with the Penguin Solutions registration web portal. Then, complete the [registration web portal steps](#).

At **Step 4**, check the **License** page of the ztC Endurance console to confirm that the license has been installed. If needed, click **Check License Now** next to **Online License Check**. When **STATUS** changes to **License installed**, the license has updated successfully, and registration is complete.

If the license does not update successfully within 5 minutes, click **Download License** in the registration web portal to download the license-key file. Continue with the next step.

3. On the **License** page of the ztC Endurance console, under **Offline License Check and Manual License Installation**, click **Choose File** under **Install an Activated License Key to the System**. Navigate to the location where you saved the file, select the file, and click **Open**.
4. On the **License** page of the ztC Endurance console, click **Upload** to upload the file to the system. If needed, click **Check License Now** next to **Online License Check**. When **STATUS** changes to **License installed**, the license has updated successfully, and registration is complete.

## On a system without Internet access

If a system does not have Internet access, you need to move a file between the location of the ztC Endurance console (which does not have Internet access) and a location with Internet access. The following procedure describes one method, though other methods are possible.

### On a computer or mobile device with access to the ztC Endurance console

1. If using a management PC, insert a USB flash drive into a USB port.  
If using a mobile device, ensure that it has access to the ztC Endurance console.

2. In the ztC Endurance console, click **License**, under **System**, in the left-hand navigation panel.
3. For Step 1, **Offline License Registration via URL File** (beneath the **Offline License Registration and Manual License Installation** bar), click **Download URL File** and save the *register\_site\_file.html* file to the USB flash drive or mobile device. If using a USB flash drive, remove it.
4. Go to a location with Internet access.

#### In a location with Internet access

1. If using a USB flash drive, insert it into a USB port of the computer with Internet access.
2. Navigate to the file you saved, and click the file name. A browser opens the file and is redirected to the Penguin Solutions registration web portal. Complete the [registration web portal steps](#).  
  
At **Step 4**, download the permanent license-key file and save it to the USB flash drive or mobile device. If using a USB flash drive, remove it.
3. Return to the location with access to the console.

#### On a computer or mobile device with access to the ztC Endurance console

1. If using a USB flash drive, insert it into a USB port on the management PC.  
  
If using a mobile device, ensure that it has access to the ztC Endurance console.
2. In the ztC Endurance console, click **License**, under **System**, in the left-hand navigation panel.
3. For Step 2, **Install an Activated License Key to the System** (beneath the **Offline License Registration and Manual License Installation** bar), click **Choose File**. Navigate to the location where you saved the license-key file, select the file, and click **Open**.
4. Click **Upload** to upload the file to the system.

## Related Topics

["Logging In to the ztC Endurance Console" on page 238](#)

## Configuring Users

Use the **Users** page to add, modify, or remove user accounts on the ztC Endurance system. You can select a user and view the time when the user's password was last updated. An administrator can also

use the page to force a selected user to change the user's password on the next login.

To open this page, in the left-hand navigation panel, click **Users** under **Administrative Tools**.

### To manage user accounts

To add a new user, click **Add** in the lower pane. On the **Add a User** window, supply the requested information and click **Save**.

To modify an existing user, click the name of a user account and click **Edit**. On the **Edit User** window, modify the information and click **Save**.

To remove an existing user, click the name of a user account and click **Remove**. On the **Confirm** window, click **Yes**.

To view the time when a user last changed the user's password, look at the **Last Password Update Time** column for a selected user. To force a user to change the user's password on the next login, an administrator selects the user and then clicks **Expire Password**.

For more information, see "[Managing User Accounts](#)" on page 259.

### To sort and locate user accounts

If you have a large number of accounts, you can click a column heading to sort the accounts by parameter. You can sort accounts by **Type**, **Username**, **First Name**, **Last Name**, **Email**, **Role**, or **Last Password Update Time**.

### Related Topics

- "[ztC Endurance Console](#)" on page 235

## Managing User Accounts

You add, edit, or remove users, specify passwords, and assign user roles to user accounts on the **Users** page in the ztC Endurance console. You can also select a user and view the time when the user's password was last updated, and an administrator can force a selected user to change the user's password on the next login.

User roles are:

- **Administrator**: full system administrator privileges
- **Platform Manager**: system administrator privileges except for adding, removing, and modifying users
- **Read-only**: ability to view but not to change system configuration or to install system software

For the procedures below, begin by opening the **Users** page: in the left-hand navigation panel, select **Users** under **Administrative Tools**.

### To add a user account

1. In the lower pane, click **Add**.
2. In the **Role** drop-down window, select **Administrator**, **Platform Manager**, or **Read-only**.
3. Enter values for the **User Name**, **Email Address**, **First Name**, **Last Name**, **Password**, and **Confirm Password** fields. User names may be from 1 to 64 characters long, and must include no white space. Passwords must conform to the "[Password Policy](#)" on [page 240](#) of the system. Click **Save**.

### To edit a user account

1. Select the account you want to edit.
2. In the lower pane, click **Edit**.
3. Change the user's information, as necessary. For example, to change a user's role, in the **Role** drop-down window, select **Administrator**, **Platform Manager**, or **Read-only**.
4. Click **Save**.

### To force a user to change the user's password

1. Select the user whose password you want to expire.
2. Click **Expire Password**.
3. Click **Yes** in the **Confirm** dialog box.

### To remove a user account

1. Select the account to remove.
2. Click **Remove** in the lower pane.
3. Click **Yes** in the **Confirm** dialog box.

**Notes:**

1. You cannot delete the default **admin** account if it is the only administrator account, although you should change its name and password by editing the account.
2. You must specify an email address for each user account, including **admin**, to enable the forgot-password feature. If a user account does not include an email address, and the user clicks the **Forgot Password?** link on the console login page, the system sends an email to *user@example.com*.

**Related Topics**

- ["ztC Endurance Console" on page 235](#)
- ["Configuring Users" on page 258](#)

**Alert History Page**

The **Alert History** page displays messages about events on the ztC Endurance system. To open this page, in the left-hand navigation panel, click **Alert History** under **Alerts & Logs**.

**Note:** Support notification alerts, e-Alerts, and SNMP traps are generated only when you enable them in the ztC Endurance console. For information, see:



- ["Configuring Remote Support Settings" on page 267](#)
- ["Configuring e-Alerts" on page 263](#)
- ["Configuring SNMP Settings" on page 265](#)

To view alert information, scroll through the alerts, which are, by default, listed in reverse chronological order. On the upper pane, click an alert to display the following information in the lower pane:

- The date and time the alert occurred
- Information about the problem and resolution (if available)
- Whether a **Support Notification**, **e-Alert**, or **SNMP Trap** was sent for this alert

On the right side of the upper pane, click the arrow to display more detailed information about the alert. Click it again to hide the detailed information.

To remove an alert, select it and click **Remove**.

To remove all alerts, click **Purge All**.



**Note:** You can remove or purge only those alerts that have been resolved and informational alerts. Outstanding alerts remain in the list and on the **Dashboard** page until you resolve them.

### Related Topics

- ["ztC Endurance Console" on page 235](#)

## Support Logs Page

The **Support Logs** page enables you to generate diagnostic files, which include the ztC Endurance system's log files and configuration information at a particular moment in time. This information enables Penguin Solutions Customer Service to resolve an issue with the system.

You can click the **Support Site** link in the top-right side of the page to go to the **Penguin Solutions Customer Service Portal**.

For additional information, see:

- ["Creating a Diagnostic File" on page 262](#)
- ["Deleting a Diagnostic File" on page 263](#)

### Related Topics

- ["ztC Endurance Console" on page 235](#)

## Creating a Diagnostic File

Diagnostic files provide the ztC Endurance system's log files and configuration information at a particular moment in time. You create a diagnostic file to help Penguin Solutions Customer Service resolve issues with the system. You can also download it.



**Note:** Automated Uptime Layer with Smart Exchange software allocates a fixed amount of storage space for diagnostic files. If a diagnostic file cannot be generated due to insufficient space, the system deletes previously created files.

### To create diagnostic files

1. In the left-hand navigation panel, click **Support Logs** under **Alerts & Logs**.
2. On the **Support Logs** page, click **Generate Diagnostic File**.

After the diagnostic file has finished generating (as indicated by **complete** appearing in the **Status** column), you can download the file.

## To download a diagnostic file

1. In the left-hand navigation panel, click **Support Logs** under **Alerts & Logs**.
2. On the **Support Logs** page, click anywhere in the row of the diagnostic file that you want to download. When a drop-down menu appears, click **Download** (↓).

## Related Topics

["ztC Endurance Console" on page 235](#)

## Deleting a Diagnostic File

Delete a diagnostic file from the ztC Endurance system.

## To delete a diagnostic file

1. In the left-hand navigation panel, click **Support Logs** under **Alerts & Logs**.
2. On the **Support Logs** page, click anywhere in the row of the diagnostic file that you want to delete. When a drop-down menu appears, click **Delete**.



**Note:** The drop-down menu does not appear while a diagnostic file is still generating.

## Related Topics

- ["ztC Endurance Console" on page 235](#)

## Configuring e-Alerts

Configuring email notifications (e-Alerts) enables the ztC Endurance system to send email to the configured list of recipients whenever an alert is generated or resolved. An e-Alert is sent every time an alert changes its state.



**Prerequisite:** In order for e-Alerts to function properly, you must configure the mail server. See ["Configuring the Mail Server" on page 243](#).

## To enable e-Alerts

1. In the left-hand navigation panel, click **e-Alerts** under **Notification**.
2. On the **e-Alerts** page, click the **Enable e-Alerts** box. The **List of Recipients** setting appears. Enable e-Alert delivery by specifying a valid sender's email address in the **List of Recipients** field. Specify email addresses for additional recipients on separate lines.

Any email address that the SMTP server accepts is sufficient.

3. Click **Save**.



**Notice:** If you notice that delivery of e-Alerts seems delayed and you see the message Message submission rate for this client has exceeded the configured limit in the sra-mgmt log, the number of e-Alerts sent in a short period of time may have exceeded the email limits set in your mail server. Contact your email administrator if you need to increase the mail server's email limits.



**Note:** When you enable or update the e-Alert configuration, generate a test alert to confirm that the email messages are received.

## To generate a test alert

Click **Generate Test Alert**. The Automated Uptime Layer with Smart Exchange software generates a test alert and sends a sample email with the subject "Test Alert" to all email recipients; SNMP sends traps to recipients of SNMP traps, if configured (see "[Configuring SNMP Settings](#)" on page 265); and Support Configuration sends a notification to your authorized Penguin Solutions service representative, if configured (see "[Configuring Remote Support Settings](#)" on page 267). A few minutes later, the software clears the test alert and sends an email notifying all email recipients that the alert has been cleared. View the **Alert History** page (see "[Alert History Page](#)" on page 261) for delivery status.



**Notice:** If the list of recipients changes immediately after a test alert is being generated, the recipient of the test alert may not receive the follow-up email stating that the alert has been cleared. To avoid this situation, do not change the list of recipients until after the recipient receives the follow-up email.

## Related Topics

- "[ztC Endurance Console](#)" on page 235

## Managing SNMP

Simple Network Management Protocol (SNMP) is a standard protocol for receiving alarms, sending traps, and monitoring system status. SNMP draws upon system-defining information that is stored in hierarchically configured management information bases (MIBs).

To configure a system to use SNMP, see "[Configuring SNMP Settings](#)" on page 265.

You can download a copy of the MIB file from the **Penguin Solutions Customer Service Portal** at <https://support.penguinsolutions.com/csm>. For instructions for downloading software, see "[Getting Help](#)" on page 293.

## Related Topics

- ["ztC Endurance Console" on page 235](#)

## Configuring SNMP Settings

Configure Simple Network Management Protocol (SNMP) settings for the ztC Endurance system to allow SNMP management applications to remotely monitor your systems. (SNMP information pertains to systems as well as many system components, such as compute modules, storage modules, disks, and so on.) You can enable SNMP requests and SNMP traps:

- **SNMP request**—A request sent to the system to retrieve the values of objects listed in the Management Information Bases (MIBs) supported by the Automated Uptime Layer with Smart Exchange software. These MIBs include a system-specific MIB that is a collection of objects describing the ztC Endurance system. You can download a copy of the MIB file from the **Penguin Solutions Customer Service Portal** at <https://support.penguinsolutions.com/csm>. For instructions for downloading software, see ["Getting Help" on page 293](#).
- **SNMP trap**—A message initiated by one of the components in the ztC Endurance system after an event such as an alert that is then sent to an identified list of recipients (typically, a network management station (NMS)).

## Managing Firewall Settings

You may need to modify some firewalls in order to communicate SNMP requests or traps from or to an NMS.

- When you installed the ztC Endurance software, your organization's firewall was automatically configured to open port 161 (Get/Walk) and 162 (Traps) for inbound and outbound traffic to the host. No user action is needed.
- If there is a firewall between the network that the ztC Endurance system is on and the location of the NMS, you may need to update your organization's firewall. Contact your network administrator about modifying the firewall.

Follow the appropriate procedure to enable SNMP requests or traps.

### To enable SNMP requests

To enable SNMP requests, perform the following procedure:

**To enable SNMP requests from the SNMP Configuration page**

1. In the left-hand navigation panel, click **SNMP Configuration** under **Notification**.
2. On the **SNMP Configuration** page, activate the check box next to **Enable SNMP Requests**. Options to specify request recipients appear below.
3. For **View/Add a Community**, select a pre-existing community from the dropdown menu or select **Add new Community** and type the community name in the resulting box.
4. Indicate whether the system will accept requests from any host or a specified set of hosts. If you choose to accept requests from a specified set of hosts, the **List of Recipients for SNMP Requests** field appears.
5. Type the IP addresses or Host Names of the intended recipients in the **List of Recipients for SNMP Requests** field.
6. Click **Save** to save the changes.

### To enable SNMP traps



**Note:** When you enable or modify the SNMP trap settings, generate a test alert to confirm that traps are received.

1. In the left-hand navigation panel, click **SNMP Configuration** under **Notification**.
2. On the **SNMP Configuration** page, activate the check box next to **Enable SNMP Traps**.
3. For the **View/Add a Community** field, select a pre-existing community from the dropdown menu or select **Add new Community** and type the community name in the resulting box.
4. In the **List of Recipients for SNMP Traps** field, type the IP addresses or Host Names of the recipients associated with the community selected above.
5. Click **Save**. (Or click **Cancel** to restore the previously saved values.)
6. Click the **Generate Test Alert** button at the bottom of the configuration window.

The Automated Uptime Layer with Smart Exchange software generates a test alert and SNMP sends traps to recipients of SNMP traps; e-Alerts send a sample email with the subject "Test Alert" to all email recipients of e-Alerts, if configured (see ["Configuring e-Alerts" on page 263](#)); and Support Configuration sends a notification to Penguin Solutions Customer Service, if configured (see ["Configuring Remote Support](#)

[Settings](#)" on page 267). Watch the Alert History log (see "[Alert History Page](#)" on page 261) for delivery status.

## Related Topics

- "[ztC Endurance Console](#)" on page 235
- "[Managing SNMP](#)" on page 264

## Configuring Remote Support Settings

When you log on to the ztC Endurance system for the first time, configure support configuration settings that enable the ztC Endurance system to send support notifications (alerts) to Penguin Solutions Customer Service via the Active Service Network (ASN) when an event requires attention.

### To configure support configuration settings



**Note:** When you enable or modify settings for **Enable Support Notifications**, generate a test alert to confirm that Penguin Solutions Customer Service can receive system health messages from your system.

1. In the left-hand navigation panel, click **Support Configuration** under **Remote Support**.
2. On the **Support Configuration** page, modify the settings, as appropriate for your system:



**Notice:** If you plan to enable remote support access, the [ASNConnect by BeyondTrust](#) software must already be installed. The **Enable Remote Support Access** option will be grayed out if it is not installed.

- **Enable Remote Support Access** allows Penguin Solutions Customer Service to remotely connect to the ztC Endurance system for troubleshooting purposes. You can enable and then disable this setting, as needed.
- **Enable Support Notifications** allows the ztC Endurance system to send health and status notifications to Penguin Solutions Customer Service. **Enable Support Notifications** sends an alert for any event that requires attention. You can also select **Enable Periodic Reporting** to send a periodic "heartbeat" call-home message to Penguin Solutions Customer Service.



**Note:** To allow Penguin Solutions Customer Service to monitor your system for failed ASN heartbeat alarms, you must enable heartbeats in the **Penguin Solutions Customer Service Portal**. See ["To configure ASN "heartbeat" alarms"](#) on page 269.

3. Click **Save** (or click **Cancel** to restore the previously saved values).
4. Configure your organization's firewall to allow support messages.

### To configure your firewall to allow support messages

Use the following information as needed to configure your organization's firewall to allow communication with Penguin Solutions Customer Service:

**Message Type:** Call-Home and Licensing  
**Protocol:** TCP  
**Port:** 443  
**Stratus support server address:** \*.stratus.com

**Message Type:** Support Diagnostics  
**Protocol:** TCP  
**Port:** 443  
**Stratus support server address:** \*.stratus.com

**Message Type:** ASNConnect  
**Protocol:** TCP  
**Port:** 443, Default proxy port: 3128 (You can change the default proxy port number.)  
**Stratus support server address:** \*.asnconnect.stratus.com

To enable SNMP management systems to receive alerts and send traps to the ztC Endurance system, configure the firewall for the following:

**Message Type:** SNMP  
**Protocol:** SNMP  
**Port:** 161 (Get/Walk) 162 (Traps)

5. Generate a test alert.

## To generate a test alert

Click **Generate Test Alert**. The system generates a test alert and Support Configuration sends a notification to Penguin Solutions Customer Service; e-Alerts send a sample email with the subject "Test Alert" to all email recipients of e-Alerts, if configured (see ["Configuring e-Alerts" on page 263](#)); and SNMP sends traps to recipients of SNMP traps, if configured (see ["Configuring SNMP Settings" on page 265](#)). View the **Alert History** page (see ["Alert History Page" on page 261](#)) for delivery status. A subsequent alert is generated if the support notification fails.

## To configure ASN "heartbeat" alarms

1. On the **Support Configuration** page, ensure that **Enable Support Notifications** is selected, and select **Enable Periodic Reporting**. Click **Save**.
2. Log in to the **Penguin Solutions Customer Service Portal** and open the ztC Endurance asset that you want to enable for periodic ASN "heartbeat" alarms. Click the **Service Network Configuration** link.
3. On the **Service Network Configuration** page, select **Enable Heartbeat**. For **Heartbeat Interval**, select **Days** and **1**, then select **Default Heartbeat Grace Period**. Click **Save Configuration**.

## Related Topics

- ["ztC Endurance Console" on page 235](#)
- ["Getting Help" on page 293](#)

## Configuring Internet Proxy Settings

Configure proxy settings for the ztC Endurance system if your organization requires a proxy server to access the Internet and you have a service agreement with Penguin Solutions or another authorized ztC Endurance service representative.

A proxy server provides a secure bridge between the ztC Endurance system and the Internet. Automated Uptime Layer with Smart Exchange software uses proxy server information for only outbound HTTP traffic related to support notification messaging and remote support access features.

## To configure Internet proxy settings

1. In the left-hand navigation panel, click **Proxy Configuration** under **Remote Support**.
2. On the **Proxy Configuration** page, click the **Enable Proxy** box to enable proxy service.
3. For **Scheme**, select either **https** or **http**.
4. In the **Proxy Server** box, type the fully-qualified proxy server host name or IP address.

5. In the **Port Number** box, type the port number if it is different from the default number (3128).
6. If the proxy server requires authentication, click the **Enable Authentication** box and type the **Username** and **Password**.

If you do not type a password, the previous password continues to be required. If the previous password was empty and you do not enter a new password, the password remains empty.

7. Click **Save** (or click **Cancel** to restore the previously saved values).

#### Related Topics

- ["ztC Endurance Console" on page 235](#)

# 10

## Chapter 10: Overview of the BMC Web Console

The BMC Web console is a Web-based interface that allows system administrators and authorized users to manage aspects of the ztC Endurance system. The BMC Web console supports the following capabilities for the user:

- Remote power control
- Remote keyboard/video/mouse (KVM)
- Remote media
- Passive examination of logs and sensors for diagnostic purposes



**Note:** Each BMC only provides information available to its own compute module. You must query both BMCs to obtain all information.

### Related Topics

- ["Prerequisites for Using the BMC Web Console" on page 271](#)
- ["Connecting to the BMC Web Console" on page 272](#)
- ["Logging In to the BMC Web Console" on page 273](#)
- ["Accessing Documentation from the BMC Web Console" on page 274](#)
- ["Unsupported BMC Web Console Features" on page 275](#)

### Prerequisites for Using the BMC Web Console

Before connecting to the BMC Web console, make sure your management PC adheres to the following requirements:

## Required Browser Settings

- Allow pop-ups from this site
- Allow file downloads from this site
- Enable JavaScript for this site (any JavaScript release can be used)
- Enable cookies for this site

The BMC Web console supports the following browsers:

- Firefox<sup>®</sup> Version 2.0 and above (Linux<sup>®</sup> and Windows<sup>®</sup>)
- Chrome<sup>™</sup> Version 2.0 and above (Windows)
- Microsoft<sup>®</sup> Edge Version 105 and above (Windows)

## Additional Requirements

For remote media connections, reduce the link speed to 100 Mbps in the network interface of the system that is hosting the remote media.

## Related Topics

- ["Overview of the BMC Web Console" on page 271](#)

## Connecting to the BMC Web Console

You connect to the BMC Web console by entering the IP address of the BMC Web console into a supported Web browser. For more information on supported browsers, see ["Prerequisites for Using the BMC Web Console" on page 271](#). You can obtain the IP address from the ztC Endurance console. If the ztC Endurance console is not running, you can obtain the IP address from the BIOS setup utility.

### To obtain the BMC Web console IP address from the ztC Endurance console

1. [Log in to the ztC Endurance console](#).
2. In the left-hand navigation panel, click **Hardware** under **System**.
3. Under **Hardware**, select the correct compute module from the list.
4. Click the **BMC** tab in the bottom pane to display the IP addresses.
5. Click the IP address of the BMC Web console to which you want to connect.

### To obtain the BMC Web console IP address from the BIOS setup utility

1. [Enter the BIOS setup utility](#).
2. Click **Server Mgmt**.

3. Under **Server Mgmt**, click **BMC Network Configuration**.
4. Scroll to **LAN Channel 1** or **LAN Channel 8** and locate **Station IP Address**. Copy the IP address, paste it into your Web browser, and hit **Enter** to connect to the BMC Web console.

## Next Steps

After you connect to the BMC Web console IP address, log in as described in "[Logging In to the BMC Web Console](#)" on page 273.

## Related Topics

- "[ztC Endurance Console](#)" on page 235
- "[Overview of the BMC Web Console](#)" on page 271

## Logging In to the BMC Web Console

After you [connect to the BMC Web console](#), log in to it by entering an authorized username and password on the login page. When logging in to the BMC Web console for the first time, use the default credentials:

Username: **admin**

Password: **admin**



**Warning:** After system installation, change the **admin** password only as described in "[Changing Passwords on a ztC Endurance System](#)" on page 229. Otherwise, a system failure may occur.



**Notice:** Prior to system installation, the BMC Web console username and password are set to the default **admin**. During the installation, you are asked to provide a new password for the **admin** account. After the installation is complete, you must create a separate user account for personal use. Passwords must be 8-16 characters. For more information, see "[To create a new user account](#)" on page 274

## To log in to the BMC Web console

1. Next to **Username** on the BMC login page, type your username (**admin**, if this is your first login).
2. Next to **Password**, type your password (**admin**, if this is your first login).
3. Click **Sign me in**.

**Note:**



While multiple users can be logged in to the BMC Web console, only one user can connect to the H5Viewer (the KVM) at a time. If a new user attempts to log in, the current user receives a message in the H5Viewer asking permission to give the new user access. If the current user does not respond, the new user is automatically granted access.

### To create a new user account

1. From the BMC Web Console dashboard, click **Settings**.
2. Under **Settings**, click **User Management**.
3. Select the desired channel from the drop-down button at the top of the page. Click any of the available profiles displayed.
4. Enter the new user's information and click **Save** when finished.

### Next Steps

If you are performing a system software installation, return to the next step of "[Starting a Factory-Installed System for the First Time](#)" on page 164.

### Related Topics

- "[Overview of the BMC Web Console](#)" on page 271

### Accessing Documentation from the BMC Web Console

The BMC Web console contains a **Help** button () located in the top right corner of each page. When you click the Help button, information about the page appears. Click the Help button again to hide the information.

### Related Topics

- "[Overview of the BMC Web Console](#)" on page 271

### Configuring DNS Settings in the BMC Web Console

Configure Domain Name System (DNS) settings in the BMC Web console to register your system's name with your DNS server while in DHCP mode. This mode is called Dynamic DNS (DDNS).

The BMC Web console has three DDNS configuration options:

- **nsupdate** (the default value) communicates directly with the DNS nameserver.
- **FQDN** requests that the DHCP server set the FQDN in the DNS server as specified by the client.
- **Hostname** requests that the DHCP server set the hostname in the DNS server.

## To specify the DDNS method in the BMC Web Console

1. [Log in to the BMC Web console](#).
2. Under **Settings** in the left-hand navigation panel, click **Network Settings**, then click **DNS Configuration** to open the **DNS Configuration** page.
3. Select the desired configuration, or contact your network administrator for the recommended settings.
4. Click **Save**.

### Related Topics

- ["Overview of the BMC Web Console" on page 271](#)

## Unsupported BMC Web Console Features

Some actions within the BMC Web console are not supported for customer use.



**Notice:** Performing any function that does not appear in ["Overview of the BMC Web Console" on page 271](#) puts the operation of the ztC Endurance system at risk.

## Browser Functions to Avoid

Once you are logged in to the BMC Web console, avoid using the following browser functions:

- The back and forward buttons on the browser
- The refresh button on the browser
- The **F5** key on the keyboard
- The backspace key on the keyboard
- The number pad on the keyboard

Instead of using the preceding browser functions, use the buttons located in the user menu in the top right corner of the BMC Web console.

## Avoid Using Caps Lock Key in KVM

The BMC KVM interface does not correctly interpret the **Caps Lock** key. Always use the **Shift** key when typing capital letters.

## Do Not Use BMC Web Console to Power Off Running System

Use the ztC Endurance console, **not** the BMC Web console, to power off a running ztC Endurance system.

Using the BMC Web console to power off a system may result in the following undesirable outcomes:

- If a user inadvertently powers off the active compute module, application downtime can occur.
- If a user powers off the standby compute module, the system-management software attempts to power it back on in order to maintain maximum system availability.

## Part 3: ztC Endurance Supporting Documents

See the following support documents for release information, and for reference and troubleshooting information.

- ["Release Notes: Automated Uptime Layer with Smart Exchange Release WIN-2.0.0.0 \(Windows\)" on page 279](#)
- ["System Reference Information" on page 287](#)

### Related Topics

- ["ztC Endurance Hardware Guide" on page 15](#)
- ["ztC Endurance Software Guide" on page 145](#)



# 11

## Chapter 11: Release Notes: Automated Uptime Layer with Smart Exchange Release WIN-2.0.0.0 (Windows)

These Release Notes (updated 12:14 PM EST on 2/17/2026) are for Automated Uptime Layer with Smart Exchange Release WIN-2.0.0.0. See the following sections:

- ["New Features and Enhancements" on page 279](#)
- ["Important Considerations" on page 279](#)
- ["Known Issues" on page 280](#)
- ["Accessing Stratus Knowledge Base Articles" on page 286](#)
- ["Getting Help" on page 286](#)

### New Features and Enhancements

Stratus Technologies is now part of Penguin Solutions. To learn more about Penguin Solutions, visit <https://www.penguinsolutions.com>.

Automated Uptime Layer with Smart Exchange Release WIN-2.0.0.0 introduces ztC Endurance 3100, 5100, and 7100 systems running Windows and Automated Uptime Layer with Smart Exchange. See ["Overview of Stratus ztC Endurance Systems" on page 17](#) for more information.

### Important Considerations

#### Hyper-V Not Supported in Automated Uptime Layer with Smart Exchange Release WIN-2.0.0.0

Hyper-V is not supported in Release 2.0.x.x.

## Do Not Update the Ubuntu System Software

Do not enable Ubuntu unattended upgrades or update the Ubuntu system software of the Standby OS from any source other than Penguin Solutions unless instructed to do so. To prevent incompatibilities and ensure the proper fault-tolerant operation of your system, use only the release and software packages that are installed with the Automated Uptime Layer with Smart Exchange software. All supported Ubuntu package updates will be bundled in future releases.

## Do Not Change BIOS Settings

Do not change any BIOS settings from their default settings without first being told to do so by Penguin Solutions Customer Service.

## Known Issues

### Do Not Use BIOS to Disable Wake On LAN

Setting Wake On LAN to Disabled in the BIOS does not disable this functionality. Instead, use the Windows settings documented in <https://learn.microsoft.com/en-us/troubleshoot/windows-client/setup-upgrade-and-drivers/wake-on-lan-feature> to disable Wake On LAN.

### Long Network Delays with PCIe Adapter During I/O Faults

Adding a PCIe adapter to a team configured in static-teaming mode could result in long network delays when an I/O module is being brought up.

### System Reports a PSU Error When Power State Changes From No Power to Powered On

When a ztC Endurance system goes from a state of no power to power, the ztC Endurance console may report that one or both PSUs have failed. Some examples of when this situation can occur are during the initial power-on, or if you remove both power cords from the system, reconnect them, and boot the system. As long as both PSU LEDs are solid green, there is no imminent danger, and you can address the issue at a convenient time. However, if the PSU LEDs are solid amber or blinking amber, there may be a legitimate problem with the PSUs that requires prompt attention.

If you encounter this issue:

- If you can physically access the ztC Endurance system:
  - a. Check the PSU LED status. Both PSU LEDs should be solid green, indicating that the PSUs are okay. See [Figure 4-3](#) and [Table 4-4](#).
  - b. Remove the power cord from the PSU that the ztC Endurance console reported as failed. See [Figure 5-19](#).

- c. Wait for the LED on the affected PSU to completely turn off. See [Figure 4-3](#).
  - d. Reconnect the power cord. See [Connecting the System to Electrical Power](#).
- If the system is remote and you cannot physically access it, contact Penguin Solutions Customer Service for assistance.

## IPv6 Must Be Enabled in BMC Web Console

ztC Endurance systems are shipped with the **Enable IPv6** setting selected in the BMC Web console. The ztC Endurance system does not work if you disable this setting.

The **Enable IPv6** setting is located in **Settings>Network Settings>Network IP Settings**. When you select this setting, the **Enable IPv6 DHCP** setting appears; select this setting as well. For more information about the BMC Web console, see "[Overview of the BMC Web Console](#)" on page 271.

## Reconfiguring System from Static IPv6 Addresses to Dynamic IPv4 Addresses

If your ztC Endurance system has been configured with static IPv6 addresses and you are reconfiguring the system to use dynamic (DHCP) IPv4 addresses, perform the following procedure before running `net_config.sh`:

1. Log in to one of the BMC Web consoles.
2. Select **Settings**, then select **Network Settings**, and then select **Network IP Settings**.
3. On the **Network IP Settings** page:
  - a. Select the **Enable IPv6 DHCP** check box.
  - b. Enter **0** in the **IPv6 Address** field.
  - c. Click **Save** and exit the BMC Web console.

Repeat this procedure on the other BMC Web console.

## Enter Only One DNS Server During Installation

If you try to enter more than one name server for the Standby OS or Windows host in the installation configuration file (`zen_config.yaml`) or when prompted in the installation script, the script will not proceed until you enter only one name server. If needed, you can add a second name server after installation by using standard Windows management utilities.

For the Standby OS specifically, if you earlier added one or more additional name servers and then you replace a compute module, you must manually add the additional name server(s) back to the Standby OS. You must do this because those operations reinstall the Standby OS, and any configuration operations outside those specified by the ztC Endurance installation are lost during the reinstallation.

## Reporting Error in zen\_verify.sh Command

After a ztC Endurance system is installed, you verify the system's installation by running the zen\_verify.sh command from a standby compute module. Currently, if the compute module's complex programmable logic device (CPLD) version is 1.2.0, zen\_verify.sh reports a failure of the CPLD firmware version. This is a reporting error, not an actual failure; Automated Uptime Layer with Smart Exchange Release WIN-2.0.0.0 supports both the 1.2.0 and 1.4.0 versions of the compute module's CPLD. You can safely ignore this error.

## Do Not Use Certain Special Characters in BMC Password

Do not use the special characters #, !, or \$ in the BMC Web console admin password. If you enter a BMC password that contains these special characters during the installation process, the installation fails with an Invalid placeholder in string error message.

## Windows Subsystem for Linux Not Supported

The Windows Subsystem for Linux (WSL) is not supported on ztC Endurance systems running AUL-Smart Exchange for Windows.

## Do Not Install OpenSSH Server Optional Feature

During the Windows installation, do not use the **OpenSSH server** feature from the **Settings > Apps > Apps & features > Optional features** menu. The installation uses a different OpenSSH application. If you try to use the **OpenSSH server** feature along with the OpenSSH application, you receive no warning, but neither the feature nor the application works.

## Installation Fails If System Connected to External Storage

Any external storage should be disconnected from the ztC Endurance system before you start Windows installation. If Windows Setup fails with the message **Windows could not apply the unattend answer file's <DiskConfiguration> setting.**, immediately disconnect external storage and click **OK**. If the message disappears before you can do this, start the installation again, first making sure that external storage is disconnected.

## Disk Manager May Display Incorrect Number of Disks During Installation

During the system software installation, before the first Smart Exchange occurs, the Windows Disk Manager may display an incorrect number of removable disks or CD-ROM drives, each with a drive letter assigned to it. To correct this display error, close the BMC KVM session to the Windows host.

## Do Not Install Windows Updates Before You Check with Penguin Solutions Customer Service

When the Windows installation completes, Windows Update is automatically disabled. Do not attempt to install any Windows updates without first checking with Penguin Solutions Customer Service.

## Do Not Modify Time Zone Except for Windows Host

Other than in the Windows host, do not modify the time zone on your ztC Endurance system. For example, do not attempt to modify the time zone on the standby OS or in the BIOS.

## Recovering Storage Pool After Reinstalling Automated Uptime Layer with Smart Exchange

If you use Storage Spaces on your ztC Endurance system and need to reinstall Automated Uptime Layer with Smart Exchange, check the state of your storage pool in **Server Manager**. If it is in an unknown, unhealthy state, perform the following procedure:

1. From **Server Manager**, right-click on the unknown/unhealthy storage pool. Select **Set Read-Write Access**.
2. Right-click each virtual disk and select **Attach Virtual Disk**. Click **Yes**.
3. Open **Disk Management**. After you attached the virtual disks in the previous step, the disks now appear as **Offline**. Right-click each disk and select **Online**. (Note that the letter assigned to the disk is not the same as the one originally assigned to the disk, but you can change it.) The virtual disk now appears as **Detached**.
4. Use Windows PowerShell to set the `IsManualAttach` value to `false` as follows:  

```
PS C:\Users\Administrator> Set-VirtualDisk -FriendlyName Pool11-vdisk1 -IsManualAttach $false
```
5. Refresh **Server Manager**.
6. Click the virtual disk, select **Properties**, and then expand **Details**.
7. From the **Property** drop-down menu, select `IsManualAttach`. The value should be **False**.
8. Optionally, if you want to verify that the value remains **False**, reboot the system, and from **Server Manager**, repeat steps 6 and 7.

## Replacement Boot Disks Not Recognized by Windows Software When Moved to Another System

If you plan to add a previously used disk to a ztC Endurance system and do not intend to preserve the existing data, run the `diskpart` command to clean the disk **before** you insert it into the system. Otherwise, the result may be unpredictable depending on the existing data (for example, if the existing data was an OS image, the system may attempt to boot from the previously used disk instead of from the intended disk).

## Recovering Degraded Data Disks After Installation

You should deport disks under either of the following circumstances:

- If you move disks of a data LUN (that is, an RDR virtual disk) from one system to another
- If you reinstall the OS on a system that currently has one or more data LUNs attached

If you do not deport disks under these circumstances, each of the formerly duplexed data LUNs are split into two identical simplexed (degraded) data LUNs, each with identical data and limited functionality. In this case, you must manually restore the data LUNs to fully functional duplexed (mirrored) LUNs by performing the following procedure:

1. In Windows PowerShell, use `.\rdmadm.exe show all` to view all disks. Note that it shows two one-disk, simplexed (degraded) LUNs for every former two-disk, duplexed (mirrored) data LUN.
2. Open Windows **Disk Management**. In most cases, half of the simplexed data LUNs will appear as **Offline**.



**Note:** If no LUNs are displayed as being **Offline**, look at the output of the `rdmadm show all` command again. Note the `Phys #` of all data LUNs with a disk that has the location `B/x`. In step 4, select LUNs with a **Disk #** that is the same as the `Phys #` that you noted.

3. Right-click the disks that appear as **Offline** and set them to **Online**. Make a note of each **Disk #**.
4. Right-click each volume of the LUN from step 3 and select **Delete Volume**.
5. In PowerShell, delete all data LUNs and convert them to pass-thru disks as shown in the following example.



**Note:** The data on the LUNs is preserved.

```
PS C:\Program Files\Stratus\bin> .\rdmadm.exe delete_plex lun3 plex0
Disk 0000_0000_0000_0001_00A0_7523_3E7F_E15C. (plex 0) removed from LUN 3
```

6. Create new LUNs from each pass-thru disk that contains data, as shown in the following example. (These are the pass-thru disks with a `Phys #` that is not the **Disk #** shown in step 3.)

```
PS C:\Program Files\Stratus\bin> .\rdmadm.exe create_lun tgt2
New LUN created from disk 0000_0000_0000_0001_00A0_7522_3E1D_F4C4.
```

7. Add the blank disks to their corresponding LUN, as shown in the following example:

```
PS C:\Program Files\Stratus\bin> .\rdmadm.exe add_plex lun2 tgt4
Disk 0000_0000_0000_0001_00A0_7522_3E1D_F565. added to LUN 337a4edc-f8a0-40ab-8920-000699989ac0
```

8. In **Disk Management**, if the disks appear as **Offline**, set them to **Online**.
9. In PowerShell, use `.\rdmadm.exe show all` to view all disks again. The recovered disks should appear as SYNCING.

### **Application Popup Event Log Messages Appear After Installing Automated Uptime Layer with Smart Exchange**

After you install Automated Uptime Layer with Smart Exchange, the Windows system event log may contain entries with the following message: The description for Event ID 56 from source Application Popup cannot be found. These event-log entries may occur after reboot or after plug-and-play removal of a storage module or an I/O module. The message does not indicate a failure and can be safely ignored.

### **Delay in Client/Server-Based Applications During Smart Exchange While Communicating Over IPv4 Addresses**

Any client/server-based application that communicates over an IP address that is assigned to a networked team configured over an x710 PCIe adapter may experience a 7- to 25-second delay during or after a Smart Exchange operation.

### **Do Not Burn Firmware on Active Compute Module During Windows Installation**

During the Windows installation, you encounter prompts asking you to update the BMC and BIOS firmware on the active compute module. However, updating the BMC and BIOS firmware during the installation may cause the installation to fail. To allow the firmware to be updated post-installation, answer No to both prompts.

After the installation, if the ztC Endurance console displays an alert stating that the updates require a reboot exchange, log in to the Windows Administrator account and run the following commands:

```
"C:\Program Files\Stratus\bin\sysupdate.exe" -allowexchange -u admin -p  
password
```

```
"C:\Program Files\Stratus\bin\sysupdate.exe" -reset system -u admin -p  
password
```

### **Possible Message About PackageManagement During System Software Installation**

During the full system software installation, if the active compute module displays the following message, type y to continue the installation.

```
Would you like PackageManagement to automatically download and install  
'nuget' now?
```

Otherwise, the installation may time out.

## **Running net\_config.sh Requires a Planned Maintenance Period**

When you run the network configuration script `net_config.sh`, it restarts the active compute module twice to complete all of the changes. Because you temporarily lose access to your applications, ensure that you run `net_config.sh` only on a non-production system or during a planned maintenance period.

## **Accessing Stratus Knowledge Base Articles**

For information about accessing Stratus Knowledge Base articles, see ["Getting Help" on page 293](#).

## **Getting Help**

If you have a technical question about ztC Endurance systems, see ["Getting Help" on page 293](#).

# 12

## Chapter 12: System Reference Information

See the following support documents for reference and troubleshooting information.

- ["System Specifications" on page 287](#)
- ["Getting Help" on page 293](#)
- ["Using the BIOS Setup Utility" on page 294](#)
- ["REST API" on page 295](#)
- ["Security" on page 295](#)

### System Specifications

Compute Module	
(Quantities listed are for each compute module)	
Physical dimensions	Maximum weight: <ul style="list-style-type: none"><li>• 31x0: 10 lb (4.5 kg)</li><li>• 51x0: 12 lb (5.4 kg)</li><li>• 71x0: 12 lb (5.4 kg)</li></ul> Length: 22.25 in. (565.2 mm) Width: 8.625 in. (219 mm) Height: 1.625 in. (41.2 mm)
Processors	3100: One Intel® Sapphire Rapids 2.0 GHz 12-core processor

	<p>5100: Two Intel Sapphire Rapids 2.0 GHz 12-core processors</p> <p>7100: Two Intel Sapphire Rapids 2.0 GHz 24-core processors</p>
System memory	<p>DIMM capacity: 64 GB</p> <p>31x0: 8 physical, DDR5 DIMM slots. Available DIMM configurations are 64 GB, 128 GB, or 256 GB.</p> <p>51x0: 16 physical, DDR5 DIMM slots. Available DIMM configurations are 128 GB, 256 GB, or 512 GB.</p> <p>71x0: 16 physical, DDR5 DIMM slots. Available DIMM configurations are 256 GB, 512 GB, or 1024 GB.</p> <p>See <a href="#">"Memory in ztC Endurance Systems" on page 22</a> for supported memory configurations for each ztC Endurance model.</p>
Ports	<p>One UART (USB-C) debug port. For use by Penguin Solutions Customer Service.</p> <p>One VGA port</p> <p>Two USB 3.0 ports</p>
<b>Storage Module</b>	
Physical dimensions	<p>Maximum weight: 10 lb (4.5 kg)</p> <p>Length: 22.25 in. (565.2 mm)</p> <p>Width: 8.625 in. (219 mm)</p> <p>Height: 1.625 in. (41.2 mm)</p>
Disk drives	<p>Up to six U.3 Non-Volatile Memory Express (NVMe) solid-state disk (SSD) drives per storage module. Available as 1.6 TB, 3.2 TB, and 6.4 TB drives.</p> <p>See <a href="#">"Disk Drives" on page 27</a> for information about installing disk drives.</p>
<b>I/O Module</b>	
Physical dimensions	<p>Maximum weight: 5 lb (2.3 kg)</p> <p>Length: 11.25 in. (285.8 mm)</p> <p>Width: 7.125 in. (181 mm)</p> <p>Height: 3.25 in. (82.6 mm)</p>

Ports	<p>Per I/O module:</p> <ul style="list-style-type: none"> <li>• Two 10 GbE ports</li> <li>• One 1 GbE (Management) port</li> </ul>
PCIe adapters	<p>See <a href="https://www.intel.com/">https://www.intel.com/</a> for detailed information about these PCIe adapters:</p> <ul style="list-style-type: none"> <li>• Intel X550-T2 (10GbE, 2P, Copper)</li> <li>• Intel X710-DA2 (10GbE, 2P, Fibre)</li> <li>• Intel XXV710-DA2 (25 GbE, 2P, Fibre)</li> </ul> <p>See <a href="https://www.marvell.com/">https://www.marvell.com/</a> for detailed information about this Fibre-Channel PCIe adapter:</p> <ul style="list-style-type: none"> <li>• Marvell® Qlogic® QLE2770-SR-SP</li> </ul> <p>See "PCIe Adapters" on page 30 for supported PCIe card configurations, including low-voltage configurations.</p>
<b>Control-Panel (Right) Ear</b>	
Port	One USB 2.0 port per system
<b>PSU</b>	
Physical dimensions	<p>Weight: 3 lb (1.4 kg)</p> <p>Length: 12.25 in. (311.2 mm)</p> <p>Width: 1.5 in. (38.1 mm)</p> <p>Height: 2.875 in. (73 mm)</p>
<b>Rail Kit</b>	
Weight, in box	9 lb (4 kg)
<b>USB Keyboard and USB Mouse</b>	
Physical dimensions	<p>Weight, in box: 2 lb (.9 kg)</p> <p>Depth: 8 in. (20.3 cm)</p> <p>Width: 19 in. (48.3 cm)</p>

	Height: 2.5 in. (6.4 cm; 2U)
<b>U.S. Power Cords</b> (see <a href="#">"Power Cords"</a> on page 40 for detailed power-cord information)	
Weight, in box	2.6 lb (1.2 kg)
<b>AC Power</b>	
Input power (watts)	<p>31x0: 1247.4W at 100V or 1425W at 200V</p> <p>51x0: 1247.4W at 100V or 2970W at 200V</p> <p>71x0: 2970W at 200V</p> <div style="border: 1px solid #c08040; padding: 10px; margin: 10px 0;"> <p><b>Notice:</b> These input power ratings are established by National Recognized Testing Laboratories (NRTL) to ensure that the product design and branch circuit supplying power can safely support operation of the product. These tests include ranges of stressful environmental operation parameters, application loading, and optional product configurations. These ratings may not reflect your specific product configuration and operational situation (that is, your system's input power may be less than these ratings), but following these ratings provides a safe installation as tested by the NRTL.</p> </div> <p>See <a href="#">"Power Cords"</a> on page 40 for supported power cords, including those for low-voltage systems.</p>
Nominal input voltage	<p>31x0: 100-127V or 200-240V, 50/60 Hz</p> <p>51x0: 100-127V or 200-240V, 50/60 Hz</p> <p>71x0: 200-240V, 50/60 Hz</p>
Power factor	0.99
Apparent Power (VA)	<p>31x0: 1260 VA 100V (12.6A x 2) or 1440 VA 200V (7.2A x 2)</p> <p>51x0: 1260VA 100V (12.6A x 2) or 3000 VA 200V (15A x 2)</p> <p>71x0: 3000 VA 200V (15A x 2)</p>
Protective earth/ground current	0.8 mA maximum for each AC power cord

Thermal load	<p>31x0: 4097 BTUs/hr</p> <p>51x0: 5868 BTUs/hr</p> <p>71x0: 6015 BTUs/hr</p>
<b>Environmental</b>	
Operating temperature	<p>41° F to 95° F (5° C to 35° C)</p> <p>For every 800 ft (243.8 m) above 2000 ft (609.6 m), lower the maximum operating temperature by 0.56° F (1° C).</p>
Storage temperature	-38° F to 140° F (-39° C to 60° C), vented
Operating altitude	0 ft to 10,000 ft (0m to 3,048m). In China markets, regulations may limit installations to a maximum altitude of 6562 ft (2000m).
Maximum rate of temperature change during operation	54° F (12° C) per hour
Relative humidity during operation	10% to 80% (noncondensing)
Relative humidity during storage	5% to 95% (noncondensing)
Maximum rate of change of temperature during storage	68°F (20°C) per hour
Shock	<p>Operating: Minimum - Fixed setting, Half-Sine wave, 2G, 10ms, 10times</p> <p>Non-operating: Minimum - Fixed in a rack hitting and dropping at a 15mm edge at 300mm/s x3</p>
Vibration	Operating: Minimum - Fixed setting, log sweep, 5 - 30Hz sine wave, 0.25G,

	<p>1.5min x2 (3min) all three axes</p> <p>Non-operating: Minimum - Fixed setting, 3 - 200Hz random wave, 0.59G, 30min, Z-Axis</p>
<b>Physical Dimensions</b>	
Weight	<p>31x0:</p> <ul style="list-style-type: none"> <li>• 67 lb (30.4 kg) to 75 lb (34 kg), without packaging or pallet</li> <li>• 101 lb (45.8 kg), maximum weight with packaging but without pallet</li> </ul> <p>51x0 and 71x0:</p> <ul style="list-style-type: none"> <li>• 71 lb (32.2 kg) to 78 lb (35.3 kg), without packaging or pallet</li> <li>• 104 lb (47.1 kg), maximum weight with packaging but without pallet</li> </ul>
Height	3.429 in. (87.10 mm)
Width	17.559 in. (446 mm)
Depth	35.826 in. (910 mm)
<b>Acoustics (22C Room Temperature)</b>	
Decibels	<p>31x0:</p> <ul style="list-style-type: none"> <li>• During pre-boot (first 20 seconds after system is powered on): &lt;=77 dBa (PSU fans run at full speed)</li> <li>• During boot: &lt;= 68.5 dBa</li> <li>• During operation: &lt;= 56.1 dBa</li> </ul> <p>51x0 and 71x0:</p> <ul style="list-style-type: none"> <li>• During pre-boot (first 20 seconds after system is powered on): &lt;=77 dBa (PSU fans run at full speed)</li> <li>• During boot: &lt;= 68.8 dBa</li> <li>• During operation: &lt;= 59.4 dBa</li> </ul>
<b>Internal Battery</b>	
Lithium battery	CR2032

## Related Topics

- "Safety Precautions" on page 49
- "Memory in ztC Endurance Systems" on page 22
- "Overview of Stratus ztC Endurance Systems" on page 17

## Getting Help

The following resources provide help related to your ztC Endurance system:

- View online documentation at the StrataDOC (ztC Endurance Version) page:  
<https://ztcendurancedoc.stratus.com>
- After you [log in](#) to the **Penguin Solutions Customer Service Portal** at <https://support.penguinsolutions.com/csm>, you can:
  - [Download software](#).
  - [Search the Knowledge Base](#). The **Knowledge Base** contains technical articles about all Stratus products, including ztC Endurance. In some cases, the online Help directly references these Knowledge Base articles (for example, KBnnnnnnn).



**Notice:** Access to the **Penguin Solutions Customer Service Portal** requires one or more Stratus products to be covered by an active service agreement. If you have questions about your service agreement, contact your authorized Penguin Solutions service representative.

## To log in to the Penguin Solutions Customer Service Portal

1. Log in to the **Penguin Solutions Customer Service Portal** at <https://support.penguinsolutions.com/csm>.

If needed, create a new account as follows:

- a. Click **Register**.
- b. Enter your contact information, including your company email address and registration code, and click **Submit**.

Your company email address must include a domain name (for example, stratus.com) for a company that is a registered customer of Penguin Solutions. The portal sends an email to administrators of the company's account to approve the request.

- c. Upon approval, click the link in the email that you receive from Penguin Solutions.
- d. Enter a new password and finish configuring your account.

If you need assistance creating an account, contact your authorized Penguin Solutions service representative.

### To download software from the Penguin Solutions Customer Service Portal

1. Log in to the **Penguin Solutions Customer Service Portal** at <https://support.penguinsolutions.com/csm>.
2. On the **Welcome to Customer Service** page, click **Software Downloads**.
3. On the **Software Downloads** page, select your product, operating system, and model, and then follow the prompts to download the desired software.

### To access the Knowledge Base from the Penguin Solutions Customer Service Portal

1. Log in to the **Penguin Solutions Customer Service Portal** at <https://support.penguinsolutions.com/csm>.
2. On the **Welcome to Customer Service** page, do one of the following:
  - In the **Search** box, enter keywords or the KB article number (KBnnnnnnn) associated with the information you need, and then click the search button.
  - Click **Knowledge**, click the name of a product, and then browse available articles.

If you cannot resolve your questions with these online resources, and the system is covered by a service agreement, contact your authorized Penguin Solutions service representative. For information, see the ztC Endurance Support page at:

<https://www.penguinsolutions.com/en-us/support>

### Related Topics

- ["ztC Endurance Supporting Documents" on page 277](#)

### Using the BIOS Setup Utility

You use the BIOS setup utility to modify BIOS settings and control system hardware.

To start the utility, as the system starts to boot and the Stratus ztC Endurance screen appears, press either the `Delete` key or the `Esc` key until the BIOS setup utility appears.



**Notice:** Do not change any BIOS settings from their default settings without first being asked to do so by Penguin Solutions Customer Service. The only exception is that if you want to disable the Secure Boot setting (new ztC Endurance systems are shipped with the Secure Boot setting enabled), you must disable it on both compute modules.

## Important Considerations When Using the BIOS Setup Utility

Consider the following important issues when you use the BIOS setup utility:

- While you are making changes to the BIOS, make sure that only one compute module is running; the other compute module must be powered down. The safest way to do this is to power on one compute module at a time. See ["Shutting Down and Restarting a Compute Module" on page 252](#).
- Stratus software does change some BIOS settings from their default values, but only at specific times. For example, Stratus software enables the OS Watchdog Timer after the software installation is complete.

## Security

This topic discusses security-related issues.

### OpenSSH Settings

During the AUL-Smart Exchange for Windows installation, the Microsoft OpenSSH application coordinates activity between the ztC Endurance Standby OS and the Windows host.

After you have installed the system software, you can disable OpenSSH by deselecting the following options in the firewall settings:

- OpenSSH for Zen Install
- OpenSSH SSH Server Preview (sshd)

## REST API

ztC Endurance systems support the Representational State Transfer (REST) application programming interface (API). With access to the REST API operations, you can collect system information and execute some administrative tasks. You can use the REST API to monitor and manage the ztC Endurance system from any location that can access the system over the network.

The system provides the REST API and interactive REST API documentation through the OpenAPI (also known as Swagger™) Specification. You can access the documentation directly on the ztC Endurance system.

To begin exploring the REST API on ztC Endurance systems, see the following sections:

- ["Accessing the REST API Documentation" on page 296](#)
- ["Logging In for REST API Testing" on page 296](#)

## Accessing the REST API Documentation

In a Web browser, open the following URL, which includes one of the hostnames or IP addresses of your ztC Endurance console:

```
https://console_hostname_or_IP_address/apidoc
```

For example, if the hostname of your ztC Endurance console is `https://sys22.yourcompany.com`, the URL for the REST API documentation is `https://sys22.yourcompany.com/apidoc`.

The URL takes you to the REST API documentation page. This page describes the API operations and syntax, and provides a helpful interface you can use to try the operations on your own system.

## Logging In for REST API Testing

### Notes:



1. The system has a limit of 9 login sessions.
2. Most operations on the REST API documentation page do not require you to perform the following procedure and instead simply require you to enter a username and password after you click **Execute**. However, if you want to use all operations listed on the REST API documentation page, you must perform the following procedure.

1. Open the REST API documentation page.
2. Click **session\_api** to expand it. The system displays the syntax for the **session\_api** operation.
3. Click **POST /sessions** to expand it, and then click **Try it out**.
4. Under **LoginRequest**, replace `string` next to `username` and `password` with the username and password for a user account with the appropriate level of privileges for the REST API operations that you want to perform. The new username and password appear in bold in the following example.

```
{
  "username": "admin",
  "password": "admin"
}
```

5. Click **Execute**.
6. Scroll down to **Server response** and view **Response body**. If the operation is successful, the response contains a REST API session authentication token (authToken). The authentication token appears in bold in the following example. If the operation is unsuccessful, the response might contain a message similar to **Unauthorized**.

```
{
  "authToken": "a8ab7d17f4f3721494eb646ce81dfc24",
  "email": "jbrown@abccompany.com",
  "maxAge": 600000,
  "role": "admin",
  "status": "success"
}
```

7. Upon a successful login, copy the authorization token text located between the quotation marks for use in a subsequent step.
8. At the top of the REST API documentation page, on the right side, click **Authorize**.
9. Under **key (apiKey)**, in the **Value** field, paste the authorization token text, and then click **Authorize**. This saves your authentication token in the request header for any operations that you “execute” from the REST API documentation page.



**Note:** The token expires after 10 minutes, and you need to repeat this step to create a new token.

To clear the token, use the **Logout** button next to it on the **Authorize** dialog box.

10. Click **Close** or **X** to close the dialog box and return to the REST API documentation page.
11. Proceed with your REST API testing.

## End-User License Agreements and Warranty

When you install a ztC Endurance system running Automated Uptime Layer with Smart Exchange, you must read and accept end-user license agreements (EULAs) associated with the system and software.

You can read the following EULAs, which are required for Automated Uptime Layer with Smart Exchange, on the Stratus web site:

**Stratus Technologies ztC Endurance Series Software End User License Agreement**  
**ztC Endurance Service Terms**  
**Stratus Technologies ztC Endurance Products Limited Return-to-Factory Hardware Warranty**

<https://www.stratus.com/services-support/customer-support/platform-support/warranty-info/>

### **Microsoft Windows Software License Terms**

You can read the Microsoft Windows software license terms on the following web site:

<https://learn.microsoft.com/en-us/legal/windows-server/system-insights-eula>

Additional EULAs cover third-party software components that are also included with the ztC Endurance system. By accepting the Stratus Technologies ztC Endurance Software EULA and using the ztC Endurance system, you also agree to the terms of the following EULAs:

### **GNU General Public License (GPL)**

<https://www.gnu.org/licenses/gpl-3.0.en.html>

### **GNU Lesser General Public License**

<https://www.gnu.org/licenses/lgpl-3.0.en.html>

### **Related Topics**

- "Starting a Factory-Installed System for the First Time" on page 164
- "Performing a Full System Software Installation" on page 167

## Glossary

---

### A

---

#### **ActiveService Network (ASN)**

The infrastructure that enables communication between a server and Penguin Solutions Customer Service or your authorized service representative. Customers can connect to ASN through a modem or over the Internet. Through ASN, alerts can be sent to customer service or your authorized service representative when an unusual event occurs on the system. ASN also enables customer service or your authorized service representative to access the server.

### B

---

#### **Baseboard Management Controller (BMC)**

Controller used for out-of-band monitoring and management of the ztC Endurance system. Each ztC Endurance system includes two BMCs; the primary BMC monitors the status of system components, even when system power is off. BMCs are equipped with an Ethernet port that can be connected to the Stratus ActiveService Network (ASN). BMCs can communicate with the ASN even when the host operating system is unavailable. This allows remote management, and, if necessary, troubleshooting by Penguin Solutions Customer Service or your authorized service representative over the internet.

#### **BIOS (basic input/output system)**

The program a computer's microprocessor uses to start the computer system after it is powered on. It also manages data flow between the computer's operating system (OS) and attached devices, such as the hard disk, video adapter, keyboard, mouse, and printer.

## C

---

### **compute module**

A customer-replaceable unit (CRU) located at the front of the ztC Endurance system. It is equipped with processors, DIMMs, BIOS, BMC, fans, and other technology to boot and run the ztC Endurance system. Each system contains two compute modules.

### **control-panel ear**

A module located at the front right of the ztC Endurance system. It houses a USB 2.0 port, power button for the ztC Endurance system, and LEDs that indicate system power status (PWR), fault conditions (ATTN), and module identification status (UID).

### **customer-replaceable unit (CRU)**

Modules that allow on-site personnel to easily remove and replace faulty components with minimal training or tools. ztC Endurance CRU modules are compute modules and their DIMMs, storage modules and their disk drives, I/O modules and their PCIe adapters, and PSUs.

## D

---

### **DIMM**

Dual In-line Memory Module. A type of computer memory module that contains random-access memory (RAM)

## E

---

### **e-Alert**

Email alert that the ztC Endurance system sends to system administrators whenever the system detects an event requiring administrator attention.

## F

---

### **fully qualified domain name**

The complete domain name of a specific computer, or host, online. A fully qualified domain name (FQDN) is composed of a hostname and a domain name, separated by a period. An FQDN designates the specific location of an object within the Domain Name System (DNS) hierarchy and allows each entity connected to the Internet to be uniquely identified and located within the Internet framework.

---

**I**

---

**I/O module**

CRU modules located at the rear of the ztC Endurance system. Each I/O module houses one 1G Ethernet port for connection to a management LAN, two 10G ports for connection to business networks, status LEDs, and five PCIe 4.0 slots for half-height PCIe adapters. The ztC Endurance system contains two I/O modules.

**Identify button**

Button that illuminates the ID LED on a specific system or component for 30 seconds, so that you can locate it. Identify buttons are found on the front of compute modules, and on the Hardware page of the ztC Endurance console.

**IPMI**

Intelligent Platform Management Interface. A set of standardized specifications for hardware-level management of computer servers

---

**L**

---

**LUN**

A Stratus software-implemented disk device. LUNs are typically duplex, meaning a mirrored set of two raw disks. If a raw disk is missing or not yet configured, the LUN is a single, raw, simplex disk.

---

**M**

---

**maintenance mode**

A ztC Endurance state that takes a module offline so that it can be serviced.

**management LAN**

The Local Area Network (LAN) used for management of the ztC Endurance system. The I/O modules house a 1G MGMT port for connection to an out-of-band management LAN.

**MTBF**

The MTBF, or mean time between failure, is the average time that a device works without an error. Regarding the MTBF: 1) Fault and event times are recorded for compute, I/O, and storage modules, as well as PSUs and disks. 2) Events are not faults, but sufficient numbers of certain events, with average in-service time between them falling below a particular threshold, will be counted as a fault. 3) Sufficient numbers of faults, with average in-service time between them falling below a particular threshold, will cause a device to be removed from service or flagged for replacement.

## N

---

### **Non-maskable interrupt (NMI)**

A process, initiated when the system is not responding, where the system controller tries to restart the system by saving the contents of memory to a dump file, and then restarting the operating system. The interrupts are intended to keep all CPUs synchronized while the system controller attempts to resolve the problem.

### **NVMe (Non-Volatile Memory Express) drive**

A protocol designed to use the PCI Express (PCIe) bus to connect SSD (solid-state drive) storage to servers or CPUs. NVMe was created by a consortium of large IT providers in 2008 to provide improved speed and performance.

## P

---

### **pass-through disk**

A pass-through disk is exposed to and usable by WinServer. It is not currently part of a mirrored LUN.

### **PCIe slot/PCIe adapter**

Peripheral Component Interconnect Express (PCIe or PCI-E) is a serial expansion bus standard for connecting a computer to one or more peripheral devices. PCIe provides lower latency and higher data transfer rates than parallel busses such as PCI and PCI-X.

### **Penguin Solutions Customer Service Portal**

Location for downloading ztC Endurance system software, reading knowledge base articles, and getting support. Access to the Penguin Solutions Customer Service Portal requires one or more Stratus products to be covered by an active service agreement, and the creation of an account. The Penguin Solutions Customer Service Portal is located at <https://support.penguinsolutions.com/csm>.

### **plex**

In the context of RAID 1, a plex is a raw disk that is part of a LUN. Its function is to mirror data, meaning every piece of data written to one disk is simultaneously written to the other, creating an exact duplicate. The plex is not individually exposed to Windows; rather, the LUN that this disk is part of is exposed to Windows.

### **power supply unit (PSU)**

Unit that connects the ztC Endurance system to electrical power. Each system includes two PSUs, located at the rear.

**R**

---

**Rapid Disk Mirroring (RDM)**

A RAID 1 concept for replicating data across multiple disks, ensuring data redundancy and accessibility. The RDM Administrator is a Stratus-proprietary command-line utility for managing mirrored disks.

**S**

---

**secure erase**

A process that permanently removes all data from a disk or solid state drive (SSD). After a device has been securely erased, you can safely use it for other purposes, such as backup images.

**Simple Network Management Protocol (SNMP)**

Network protocol used to monitor the status of network-connected devices. Configuring SNMP settings on ztC Endurance allows remote monitoring of the system by management applications, and allows the system to send messages to designated recipients if alert conditions occur.

**Smart Exchange**

A proprietary process that maintains system availability and protects against data loss. If the ztC Endurance system detects a degradation or failure within the active compute module, Smart Exchange: 1) Automatically activates the standby compute module and copies over in-process data. 2) Reroutes all I/O and storage connected to the original active compute module to the newly activated compute module. Smart Exchange occurs while the system is running and, except for a very brief pause (usually less than one second), is undetectable to the operating system and customer applications.

**standby power**

Low-level power that remains present even after the ztC Endurance system has been powered down. Standby power enables the primary Baseboard Management Controller (BMC) to monitor the status of system components, even when system power is off. Using standby power, administrators or ztC Endurance Customer Service (if authorized) can connect to the system through the 1G management port to diagnose problems, or to turn system power on and off from a remote location. To completely shut off power, the power cords must be unplugged.

**storage adapter**

An individual NVMe disk's PCIe hardware adapter.

**storage module**

CRU modules located at the front of the ztC Endurance system. Storage modules are equipped with status LEDs and include six slots for data disk drives. Each ztC Endurance system contains two storage modules.

**Z**

---

**ztC Endurance console**

A browser-based interface that provides management and monitoring of a ztC Endurance system from a remote management computer. You can perform many administrative operations from the console because it provides access to the system as a whole, as well as to individual modules, components of modules, and other resources.